



**AGENDA**  
**CITY COUNCIL OF THE CITY OF MORENO VALLEY**  
**MORENO VALLEY COMMUNITY SERVICES DISTRICT**  
**CITY AS SUCCESSOR AGENCY FOR THE**  
**COMMUNITY REDEVELOPMENT AGENCY OF**  
**THE CITY OF MORENO VALLEY**  
**MORENO VALLEY HOUSING AUTHORITY**  
**BOARD OF LIBRARY TRUSTEES**

**January 15, 2019**

**REGULAR MEETING – 6:00 PM**  
**City Council Study Sessions**  
Second Tuesday of each month – 6:00 p.m.

**City Council Meetings**  
Special Presentations – 5:30 P.M.  
First & Third Tuesday of each month – 6:00 p.m.

**City Council Closed Session**  
*Will be scheduled as needed at 4:30 p.m.*  
City Hall Council Chamber – 14177 Frederick Street

*Upon request, this agenda will be made available in appropriate alternative formats to persons with disabilities, in compliance with the Americans with Disabilities Act of 1990. Any person with a disability who requires a modification or accommodation in order to participate in a meeting should direct such request to Guy Pegan, ADA Coordinator, at 951.413.3120 at least 72 hours before the meeting. The 72-hour notification will enable the City to make reasonable arrangements to ensure accessibility to this meeting.*

Dr. Yxstian A. Gutierrez, Mayor

Victoria Baca, Mayor Pro Tem  
Ulises Cabrera, Council Member

David Marquez, Council Member  
Dr. Carla J. Thornton, Council Member

**AGENDA**  
**CITY COUNCIL OF THE CITY OF MORENO VALLEY**  
**January 15, 2019**

**CALL TO ORDER - 5:30 PM**

**SPECIAL PRESENTATIONS**

1. Business Spotlights
2. Rancho Verde Crimson Regiment
3. Safe Surrender Awareness Month

**AGENDA  
JOINT MEETING OF THE  
CITY COUNCIL OF THE CITY OF MORENO VALLEY  
MORENO VALLEY COMMUNITY SERVICES DISTRICT  
CITY AS SUCCESSOR AGENCY FOR THE  
COMMUNITY REDEVELOPMENT AGENCY OF THE  
CITY OF MORENO VALLEY  
MORENO VALLEY HOUSING AUTHORITY  
AND THE BOARD OF LIBRARY TRUSTEES**

**\*THE CITY COUNCIL RECEIVES A SEPARATE STIPEND FOR CSD  
MEETINGS\***

**REGULAR MEETING – 6:00 PM  
JANUARY 15, 2019**

**CALL TO ORDER**

Joint Meeting of the City Council, Community Services District, City as Successor Agency for the Community Redevelopment Agency, Housing Authority and the Board of Library Trustees - actions taken at the Joint Meeting are those of the Agency indicated on each Agenda item.

**PLEDGE OF ALLEGIANCE**

**INVOCATION**

Dr. Reverend Mark Krom, Mark Krom Ministries

**ROLL CALL**

**INTRODUCTIONS**

**PUBLIC COMMENTS ON MATTERS ON THE AGENDA WILL BE TAKEN UP AS THE ITEM IS CALLED FOR BUSINESS, BETWEEN STAFF'S REPORT AND CITY COUNCIL DELIBERATION (SPEAKER SLIPS MAY BE TURNED IN UNTIL THE ITEM IS CALLED FOR BUSINESS.)**

**PUBLIC COMMENTS ON ANY SUBJECT NOT ON THE AGENDA UNDER THE JURISDICTION OF THE CITY COUNCIL**

Those wishing to speak should complete and submit a BLUE speaker slip to the Sergeant-at-Arms. There is a three-minute time limit per person. All remarks and questions shall be addressed to the presiding officer or to the City Council.

## **JOINT CONSENT CALENDARS (SECTIONS A-D)**

All items listed under the Consent Calendars, Sections A, B, C, and D are considered to be routine and non-controversial, and may be enacted by one motion unless a member of the City Council, Community Services District, City as Successor Agency for the Community Redevelopment Agency, Housing Authority or the Board of Library Trustees requests that an item be removed for separate action. The motion to adopt the Consent Calendars is deemed to be a separate motion by each Agency and shall be so recorded by the City Clerk. Items withdrawn for report or discussion will be heard after public hearing items.

### **A. CONSENT CALENDAR-CITY COUNCIL**

- A.1. ORDINANCES - READING BY TITLE ONLY - THE MOTION TO ADOPT AN ORDINANCE LISTED ON THE CONSENT CALENDAR INCLUDES WAIVER OF FULL READING OF THE ORDINANCE.

**Recommendation:** Waive reading of all Ordinances.

- A.2. MINUTES - CITY COUNCIL - SPECIAL MEETING - DEC 11, 2018 6:00 PM

**Recommendation:** Approve as submitted.

- A.3. MINUTES - CITY COUNCIL - CLOSED SESSION - DEC 18, 2018 4:30 PM

**Recommendation:** Approve as submitted.

- A.4. MINUTES - CITY COUNCIL - REGULAR MEETING - DEC 18, 2018 6:00 PM

**Recommendation:** Approve as submitted.

- A.5. LIST OF PERSONNEL CHANGES (Report of: Human Resources)

**Recommendation:**

1. Ratify the list of personnel changes as described.

- A.7. PURSUANT TO A LANDOWNER PETITION, ANNEX THREE PARCELS INTO COMMUNITY FACILITIES DISTRICT NO. 2014-01 (MAINTENANCE SERVICES) - AMENDMENT NO. 31 (RESO. NO. 2019-\_\_) (Report of: Public Works)

**Recommendation:**

Acting as the legislative body of Community Facilities District No. 2014-01 (Maintenance Services), adopt Resolution No. 2019-\_\_, a Resolution of the City Council of the City of Moreno Valley, California, ordering the annexation of territory to City of Moreno Valley Community Facilities District No. 2014-01 (Maintenance Services) and approving the amended map for said District.

- A.8. APPROVE AND EXECUTE AGREEMENT WITH MICON CONSTRUCTION FOR THE CONSTRUCTION OF A SKATE PARK AT MORENO VALLEY COMMUNITY PARK (Report of: Parks & Community Services)

**Recommendations:**

1. Approve the Agreement for the Construction of a Skate Park at Moreno Valley Community Park with Micon Construction.
2. Authorize the Executive Director to execute the Agreement for the Construction of a Skate Park at Moreno Valley Community Park with Micon Construction; and issuance of the Purchase Order for construction once the Agreement has been fully executed.
3. Authorize the Executive Director to execute any subsequent related Extensions or Amendments to the Agreement within the authorized funding, subject to the approval of the City Attorney.
4. Authorize the Parks and Community Services Director to accept the improvements into the Moreno Valley Community Services District's maintained system upon acceptance of the improvements as complete.

- A.9. COUNCIL DISCRETIONARY EXPENDITURE REPORTS FOR FISCAL YEAR 2018/2019 AS OF JULY 1, 2018 THROUGH NOVEMBER 30, 2018 (Report of: City Clerk)

**Recommendation:**

1. Receive and file the Fiscal Year 2018/2019 Council Discretionary Expenditure Report for July 1, 2018 through November 30, 2018.

- A.10. 2019 CITY COUNCIL COMMISSION, BOARD, AND TASKFORCE PARTICIPATION APPOINTMENTS (Report of: City Clerk)

**Recommendations: That the City Council:**

1. Ratify as one slate the Mayor's appointments to the various committees as noted on the 2019 Council Committee Participation List.

**B. CONSENT CALENDAR-COMMUNITY SERVICES DISTRICT**

- B.1. ORDINANCES - READING BY TITLE ONLY - THE MOTION TO ADOPT AN ORDINANCE LISTED ON THE CONSENT CALENDAR INCLUDES WAIVER OF FULL READING OF THE ORDINANCE.

**Recommendation:** Waive reading of all Ordinances.

B.2. MINUTES - SPECIAL MEETING OF DEC 11, 2018 6:00 PM (See A.2)

**Recommendation:** Approve as submitted.

B.3. MINUTES - CLOSED SESSION OF DEC 18, 2018 4:30 PM (See A.3)

**Recommendation:** Approve as submitted.

B.4. MINUTES - REGULAR MEETING OF DEC 18, 2018 6:00 PM (See A.4)

**Recommendation:** Approve as submitted.

B.5. APPROVE THE FIRST AMENDMENT TO THE ON-SITE AND/OR PROFESSIONAL SERVICES AGREEMENT (CONTRACT NO. CSD 2018-50) FOR LANDSCAPE MAINTENANCE SERVICES (LANDSCAPE MAINTENANCE - ZONE 02) (Report of: Public Works)

**Recommendations:**

1. Approve the First Amendment to the On-Site and/or Professional Services Agreement (Contract No. CSD 2018-50) for Landscape Maintenance – Zone 02, Maintenance of Parkway, Median, and Open Space Landscaping and Irrigation (“Agreement”) with Mariposa Landscapes, Inc., 6232 Santos Diaz St., Irwindale, CA 91702, to provide landscape and irrigation maintenance services for Zone 02 of Landscape Maintenance District (LMD) No. 2014-02 for a total contract amount Not-To-Exceed (NTE) \$1,619,200.
2. Approve the budget adjustment as set forth in the Fiscal Impact section of this report.
3. Authorize the Public Works Director/City Engineer to execute the First Amendment, in substantially the form as attached hereto, subject to the approval of the City Attorney.

B.6. NAMING OF PARK LOCATED NEAR RAINBOW RIDGE ELEMENTARY SCHOOL, EAST OF INDIAN AVENUE AND SOUTH OF SANTIAGO AVENUE (Report of: Parks & Community Services)

**Recommendation:**

1. Adopt the name for the new park located within Tract 36760, near Rainbow Ridge Elementary School, east of Indian Street and south of Santiago Avenue, as “Santiago Park.”

## **C. CONSENT CALENDAR - HOUSING AUTHORITY**

- C.1. ORDINANCES - READING BY TITLE ONLY - THE MOTION TO ADOPT AN ORDINANCE LISTED ON THE CONSENT CALENDAR INCLUDES WAIVER OF FULL READING OF THE ORDINANCE.

**Recommendation:** Waive reading of all Ordinances.

- C.2. MINUTES - SPECIAL MEETING OF DEC 11, 2018 6:00 PM (See A.2)

**Recommendation:** Approve as submitted.

- C.3. MINUTES - CLOSED SESSION OF DEC 18, 2018 4:30 PM (See A.3)

**Recommendation:** Approve as submitted.

- C.4. MINUTES - REGULAR MEETING OF DEC 18, 2018 6:00 PM (See A.4)

**Recommendation:** Approve as submitted.

## **D. CONSENT CALENDAR - BOARD OF LIBRARY TRUSTEES**

- D.1. ORDINANCES - READING BY TITLE ONLY - THE MOTION TO ADOPT AN ORDINANCE LISTED ON THE CONSENT CALENDAR INCLUDES WAIVER OF FULL READING OF THE ORDINANCE.

**Recommendation:** Waive reading of all Ordinances.

- D.2. MINUTES - SPECIAL MEETING OF DEC 11, 2018 6:00 PM (See A.2)

**Recommendation:** Approve as submitted.

- D.3. MINUTES - CLOSED SESSION OF DEC 18, 2018 4:30 PM (See A.3)

**Recommendation:** Approve as submitted.

- D.4. MINUTES - REGULAR MEETING OF DEC 18, 2018 6:00 PM (See A.4)

**Recommendation:** Approve as submitted.

## **E. PUBLIC HEARINGS**

Questions or comments from the public on a Public Hearing matter are limited to five minutes per individual and must pertain to the subject under consideration.

Those wishing to speak should complete and submit a GOLDENROD speaker slip to the Sergeant-at-Arms.

E.1. PUBLIC HEARING FOR ONE NATIONAL POLLUTANT DISCHARGE ELIMINATION SYSTEM MAIL BALLOT PROCEEDING (Report of: Public Works)

**Recommend that the City Council:**

1. Conduct the Public Hearing and accept public testimony for the mail ballot proceeding(s) for the National Pollutant Discharge Elimination System (NPDES) Common Interest, Commercial, Industrial, and Quasi-Public Use maximum Regulatory Rate to be applied to three property tax bill(s);
2. Direct the City Clerk to open and count the returned NPDES ballot(s);
3. Verify and accept the results of the mail ballot proceeding(s) as maintained by the City Clerk on the Official Tally Sheet;
4. Receive and file the Official Tally Sheet with the City Clerk's office; and,
5. If approved, set the rate and impose the NPDES Common Interest, Commercial, Industrial, and Quasi-Public Use Regulatory Rate on the Assessor's Parcel Number(s) as mentioned.

**F. ITEMS REMOVED FROM CONSENT CALENDARS FOR DISCUSSION OR SEPARATE ACTION**

**G. GENERAL BUSINESS – NONE**

**H. REPORTS**

H.1. CITY COUNCIL REPORTS

(Informational Oral Presentation - not for Council action)

March Joint Powers Commission (JPC)

Riverside County Habitat Conservation Agency (RCHCA)

Riverside County Transportation Commission (RCTC)

Riverside Transit Agency (RTA)

Western Riverside Council of Governments (WRCOG)

Western Riverside County Regional Conservation Authority (RCA)

School District/City Joint Task Force



H.2. CITY MANAGER'S REPORT

(Informational Oral Presentation - not for Council action)

H.3. CITY ATTORNEY'S REPORT

(Informational Oral Presentation - not for Council action)

**CLOSING COMMENTS AND/OR REPORTS OF THE CITY COUNCIL, COMMUNITY SERVICES DISTRICT, CITY AS SUCCESSOR AGENCY FOR THE COMMUNITY REDEVELOPMENT AGENCY, HOUSING AUTHORITY AND THE BOARD OF LIBRARY TRUSTEES.**

**ADJOURNMENT**

**PUBLIC INSPECTION**

The contents of the agenda packet are available for public inspection on the City's website at [www.moval.org](http://www.moval.org) and in the City Clerk's office at 14177 Frederick Street during normal business hours.

Any written information related to an open session agenda item that is known by the City to have been distributed to all or a majority of the City Council less than 72 hours prior to this meeting will be made available for public inspection on the City's website at [www.moval.org](http://www.moval.org) and in the City Clerk's office at 14177 Frederick Street during normal business hours.

**CERTIFICATION**

I, Pat Jacquez-Nares, City Clerk of the City of Moreno Valley, California, certify that 72 hours prior to this Regular Meeting, the City Council Agenda was posted on the City's website at: [www.moval.org](http://www.moval.org) and in the following three public places pursuant to City of Moreno Valley Resolution No. 2007-40:

City Hall, City of Moreno Valley  
14177 Frederick Street

Moreno Valley Library  
25480 Alessandro Boulevard

Moreno Valley Senior/Community Center  
25075 Fir Avenue

Pat Jacquez-Nares, CMC & CERA  
City Clerk

Date Posted: January 10, 2019

**TO:**

**FROM:** Pat Jacquez-Nares, City Clerk

**AGENDA DATE:** January 15, 2019

**TITLE:** BUSINESS SPOTLIGHTS

---

**RECOMMENDED ACTION**

**CITY COUNCIL GOALS**

None

**CITY COUNCIL STRATEGIC PRIORITIES**

1. Economic Development
2. Public Safety
3. Library
4. Infrastructure
5. Beautification, Community Engagement, and Quality of Life
6. Youth Programs

**ATTACHMENTS**

None

**APPROVALS**

**TO:**

**FROM:** Pat Jacquez-Nares, City Clerk

**AGENDA DATE:** January 15, 2019

**TITLE:** RANCHO VERDE CRIMSON REGIMENT

---

**RECOMMENDED ACTION**

**CITY COUNCIL GOALS**

None

**CITY COUNCIL STRATEGIC PRIORITIES**

1. Economic Development
2. Public Safety
3. Library
4. Infrastructure
5. Beautification, Community Engagement, and Quality of Life
6. Youth Programs

**ATTACHMENTS**

None

**APPROVALS**

**TO:**

**FROM:** Pat Jacquez-Nares, City Clerk

**AGENDA DATE:** January 15, 2019

**TITLE:** SAFE SURRENDER AWARENESS MONTH

---

**RECOMMENDED ACTION**

**CITY COUNCIL GOALS**

None

**CITY COUNCIL STRATEGIC PRIORITIES**

1. Economic Development
2. Public Safety
3. Library
4. Infrastructure
5. Beautification, Community Engagement, and Quality of Life
6. Youth Programs

**ATTACHMENTS**

None

**APPROVALS**

**MINUTES  
JOINT MEETING OF THE  
CITY COUNCIL OF THE CITY OF MORENO VALLEY  
MORENO VALLEY COMMUNITY SERVICES DISTRICT  
CITY AS SUCCESSOR AGENCY FOR THE  
COMMUNITY REDEVELOPMENT AGENCY OF THE  
CITY OF MORENO VALLEY  
MORENO VALLEY HOUSING AUTHORITY  
BOARD OF LIBRARY TRUSTEES**

**SPECIAL MEETING – 6:00 PM  
December 11, 2018**

**CALL TO ORDER**

The Joint Meeting of the City Council, Community Services District, City as Successor Agency for the Community Redevelopment Agency of the City of Moreno Valley, Moreno Valley Housing Authority and the Board of Library Trustees was called to order at 6:07 p.m. by Mayor Gutierrez in the Council Chamber located at 14177 Frederick Street.

**INVOCATION**

Senior Pastor Donald Wilson, Lighthouse Baptist Church

**PRESENTATION OF COLORS**

Blue Eagles Total Force Honor Guard

**NATIONAL ANTHEM**

Canyon Springs High School Choir

**PLEDGE OF ALLEGIANCE**

The Pledge of Allegiance was led by Frank Wright.

**AMERICA THE BEAUTIFUL**

Emily Adkins, Soloist, Canyon Springs High School

**ROLL CALL**

|          |                          |                |
|----------|--------------------------|----------------|
| Council: | Dr. Yxstian A. Gutierrez | Mayor          |
|          | Victoria Baca            | Mayor Pro Tem  |
|          | David Marquez            | Council Member |

Ulises Cabrera  
Jeffrey J. Giba

Council Member  
Council Member

## INTRODUCTIONS

|        |                    |   |
|--------|--------------------|---|
| Staff: | Pat Jacquez-Nares  | City Clerk  |
|        | Angel Migao        | Executive Assistant to the Mayor and City Council |
|        | Marshall Eyerman   | Chief Financial Officer/City Treasurer            |
|        | Martin Koczanowicz | City Attorney                                     |
|        | Tom DeSantis       | City Manager                                      |
|        | Allen Brock        | Assistant City Manager                            |
|        | Mike Lee           | Economic Development Director                     |
|        | Rick Sandzimier    | Community Development Director                    |
|        | David Kurylowicz   | Chief of Police                                   |
|        | Abdul Ahmad        | Fire Chief  |
|        | Kathleen Sanchez   | Human Resources Director                          |
|        | Patti Solano       | Parks and Community Services Director             |
|        | Michael Wolfe      | Public Works Director/City Engineer               |

Mayor Gutierrez acknowledged the public officials and representatives in the audience.

## PUBLIC COMMENTS ON MATTERS ON THE AGENDA ONLY

### Robert Harris

1. Congratulated the incoming and reelected Council members.

### Cesar McGuire

1. Opposes Item No. G.1.

### Julie Duborg

1. Supports Item No. G.1.

### Martin Cabrera Sr.

1. Congratulated Council Member Cabrera on his reelection.

### Tom Jerele

1. Thanked Council Member Giba for his service to the City.
2. Congratulated incoming and reelected Council Members.

### Rafael Brugueras

1. Professed his gratitude to Council Member Giba.

### George Tektonopolis

1. Opposes Item No. G.1.

### Chris Francy

1. Opposes Item No. G.1.

Christina Francy

1. Opposes Item No. G.1.

Roy Bleckert

1. Supports the free market.

Evan Morgan

1. Supports Item No. G.1.

Louise Palomarez

1. Supports Item No. G.1.

**SPECIAL ORDER OF BUSINESS**

1. RESOLUTION RECITING THE FACT OF THE GENERAL MUNICIPAL ELECTION HELD ON NOVEMBER 6, 2018, DECLARING THE OFFICIAL RESULTS AND SUCH OTHER MATTERS AS PROVIDED BY LAW (RESO NO. 2018-83) (Report of: City Clerk)

City Clerk Jacquez-Nares provided the report.

**Recommendation: That the City Council:**

1. Adopt A Resolution of the City Council of the City of Moreno Valley, California, reciting the fact of the General Municipal Election held on November 6, 2018, declaring the results and such other matters as provided by law.

|                  |   |
|------------------|---|
| <b>RESULT:</b>   | <b>APPROVED [UNANIMOUS]</b>   |
| <b>MOVER:</b>    | David Marquez, Council Member   |
| <b>SECONDER:</b> | Jeffrey J. Giba, Council Member   |
| <b>AYES:</b>     | Dr. Yxstian A. Gutierrez, Victoria Baca, David Marquez, Ulises Cabrera, Jeffrey J. Giba |

**RECOGNITION OF OUTGOING CITY OFFICIALS**

Mayor Gutierrez recognized Council Member Giba for his service.

Council Member Giba expressed his honor in representing the City.

**PRESENTATION OF THE CERTIFICATES OF ELECTION AND ADMINISTRATION OF THE OATHS OF OFFICE TO NEWLY ELECTED OFFICIALS**

After taking her oath of office, Council Member Thornton expressed her gratitude for the opportunity to represent District two.

After taking his oath of office, Council Member Cabrera thanked all those who supported him in his reelection campaign.

After taking his oath of office, Mayor Gutierrez congratulated Council Member Thornton and Council Member Cabrera. He communicated his gratefulness to his parents and others.

**RECOGNITION TO NEWLY ELECTED CITY OFFICIALS BY THE CITY COUNCIL AND/OR OTHER PUBLIC OFFICERS**

Oscar Valdepena

- 1. Applauded the incoming and reelected Council Members.

Jaime Hurtado

- 1. Honored the incoming and reelected Council Members.

**RECESS TO RECEPTION IN THE MAIN LOBBY**

Mayor Gutierrez recessed the meeting at 7:27 pm.

**RECONVENE CITY COUNCIL MEETING**

Mayor Gutierrez reconvened the meeting at 8:32 pm.

**ROLL CALL**

|          |                          |                |
|----------|--------------------------|----------------|
| Council: | Dr. Yxstian A. Gutierrez | Mayor          |
|          | Victoria Baca            | Mayor Pro Tem  |
|          | David Marquez            | Council Member |
|          | Ulises Cabrera           | Council Member |
|          | Dr. Carla J. Thornton    | Council Member |

**JOINT CONSENT CALENDARS (SECTIONS A-D)**

**RESULT:** APPROVED [UNANIMOUS]  
**MOVER:** Victoria Baca, Mayor Pro Tem  
**SECONDER:** David Marquez, Council Member  
**AYES:** Dr. Yxstian A. Gutierrez, Victoria Baca, David Marquez, Ulises Cabrera, Dr. Carla J. Thornton

**A. CONSENT CALENDAR-CITY COUNCIL**

Mayor Gutierrez opened the Consent Agenda items for public comments. There being no members of the public to come forward to speak, he closed the Consent Agenda. Mayor Gutierrez announced that Environmental and Historical Preservation Board nominee Gerald Michael Budlong passed away.

- A.1. City Council - Special Meeting (Closed Session) - Nov 13, 2018 4:30 PM

**Recommendation:** Approve as submitted.

- A.2. City Council - Special Meeting - Nov 13, 2018 6:00 PM

Minutes Acceptance: Minutes of Dec 11, 2018 6:00 PM (CONSENT CALENDAR-CITY COUNCIL)



**Recommendation:** Approve as submitted.

A.3. City Council - Special Meeting - Nov 19, 2018 5:00 PM

**Recommendation:** Approve as submitted.

A.4. RECEIVE THE ANNUAL AB1600 COMPLIANCE REPORT FOR FISCAL YEAR 2017-18 AND THE FIVE-YEAR REPORT (Report of: Financial & Management Services)

**Recommendations:**

1. Receive and file the Annual AB 1600 Compliance Report for FY 2017-18 and the Five-Year Report in compliance with California Government Code sections 66006 and 66001.
2. Approve the finding that staff has demonstrated a continuing need to hold unexpended Development Impact Fees.

A.5. APPROVE A RESOLUTION OF THE CITY COUNCIL OF THE CITY OF MORENO VALLEY TO AMEND THE ELECTRIC RATES FOR MORENO VALLEY UTILITY (RESO NO. 2018-84) (Report of: Financial & Management Services)

**Recommendation:**

1. Approve Resolution No. 2018-84. A Resolution of the City Council of the City of Moreno Valley, California, to Amend the Electric Rates for Moreno Valley Utility (MVU).

A.6. AUTHORIZE AN INCREASE TO THE CONTRACT AMOUNT WITH HIGH COUNTRY LINE CONSTRUCTION, INC. FOR THE CONSTRUCTION OF THE KITCHING STREET ELECTRICAL SUBSTATION AND SWITCHYARD PROJECT (Report of: Financial & Management Services)

**Recommendations:**

1. Approve a Change Order and an increase in existing Purchase Order for High Country Line Construction, Inc. in the amount of \$465,000 to cover unanticipated work including additional work required by Southern California Edison.
2. Authorize the City Manager to execute a Change Order to High Country Line Construction, Inc.

- A.7. AUTHORIZE THE AWARD OF THE CONSTRUCTION CONTRACT TO HOT LINE CONSTRUCTION, INC. FOR THE HEACOCK CROSSTOWN TIE IMPROVEMENTS, PROJECT NO. 805 0043 (AGMT NO. 2018-558) (Report of: Financial & Management Services)

**Recommendations:**

1. Award the construction contract to Hot Line Construction, Inc., 9020 Brentwood Boulevard, Suite H, Brentwood, CA 94513, the lowest responsible bidder, for the Heacock Crosstown Tie Project.
2. Authorize the City Manager to execute a contract with Hot Line Construction, Inc.
3. Authorize the issuance of a Purchase Order to Hot Line Construction, Inc. for the amount of \$1,816,798 (\$1,579,824 bid amount plus 15% contingency) when the contract has been signed by all parties.
4. Authorize the Chief Financial Officer/City Treasurer to execute any subsequent related minor change orders to the contract with Hot Line Construction, Inc. up to, but not exceeding, the 15% contingency amount of \$236,974, subject to the approval of the City Attorney.
5. Amend the FY 2017/2018 & 2018/2019 Adopted Capital Improvement Plan and Appropriate \$357,300 from the Moreno Valley Utility Fund (Account No. 6011 30 80 80005 720199) to cover the construction and administrative costs.

- A.8. LIST OF PERSONNEL CHANGES (Report of: Human Resources)

**Recommendation:**

1. Ratify the list of personnel changes as described.

- A.9. CONSIDERATION OF PROPOSED VOLUNTARY EARLY RETIREMENT INCENTIVE PROGRAM (Report of: Human Resources)

**Recommendation:**

1. Staff recommends that the City Council approve the Proposed Voluntary Early Retirement Incentive (VERI) program.

- A.10. APPROVAL TO FUND A COMMUNITY SERVICES COORDINATOR POSITION (Report of: Human Resources)

**Recommendations:**

1. Authorize the Parks and Community Services Department to de-fund

one Administrative Assistant position and fund one Community Services Coordinator position.

- 2. Authorize the City Position Summary, as amended, to reflect the de-funding of one Administrative Assistant position and the funding of one Community Services Coordinator position.

A.11. TELECOMMUNICATIONS LICENSE AGREEMENT WITH LOS ANGELES SMSA LIMITED PARTNERSHIP, d/b/a VERIZON WIRELESS, FOR A CELL TOWER AT EL POTRERO PARK (AGMT NO. 2018-513) (Report of: Parks & Community Services)

**Recommendations:**

- 1. Authorize the Mayor to execute a Telecommunications License Agreement with Los Angeles SMSA Limited Partnership, d/b/a Verizon Wireless, on the property known as El Potrero Park.
- 2. Authorize the City Manager to execute any subsequent related Extensions or Amendments to the Agreement, subject to the approval of the City Attorney.
- 3. Approve the amended budget as set forth in the Fiscal Impact Section of this report.

A.12. COUNCIL DISCRETIONARY EXPENDITURE REPORTS FOR FISCAL YEAR 2018/2019 AS OF JULY 1, 2018 THROUGH OCTOBER 31, 2018 (Report of: City Clerk)

**Recommendation:**

- 1. Receive and file the Fiscal Year 2018/2019 Council Discretionary Expenditure Report for July 1, 2018 through October 31, 2018.

A.13. MAYORAL APPOINTMENTS TO THE EMERGING LEADERS COUNCIL, SENIOR CITIZEN'S BOARD AND THE ENVIRONMENTAL AND HISTORICAL PRESERVATION BOARD (Report of: City Clerk)

**Recommendation:**

- 1. Receive and confirm the Mayoral appointments as follows:

**Emerging Leaders Council**

| <u>Name</u>     | <u>Position</u> | <u>Term</u>          |
|-----------------|-----------------|----------------------|
| Patrick Samones | Member          | Ending<br>05/31/2020 |

Minutes Acceptance: Minutes of Dec 11, 2018 6:00 PM (CONSENT CALENDAR-CITY COUNCIL)

**Senior Citizen’s Board**

| <u>Name</u>       | <u>Position</u> | <u>Term</u>          |
|-------------------|-----------------|----------------------|
| Cleveland Johnson | Member          | Ending<br>06/30/2021 |

**Environmental and Historical Preservation Board**

| <u>Name</u>            | <u>Position</u> | <u>Term</u>          |
|------------------------|-----------------|----------------------|
| Gerald Michael Budlong | Member          | Ending<br>06/30/2021 |

A.14. ADOPTION OF ORDINANCE LOCAL MORENO VALLEY COMMERCIAL CANNABIS ACTIVITY TAX. (ORD NO. 946) (Report of: City Clerk)

**Recommendation: That the City Council:**

1. By motion, adopt an Ordinance of the People of the City of Moreno Valley, California, Amending Moreno Valley Municipal Code to add Chapter 3.28 “Commercial Cannabis Activity Tax” Setting the Maximum Amount of Tax Rate at Eight Percent (8%) And \$15.00 Per Square Foot for Cultivation Businesses for the Purpose of Funding Local General Municipal Services

**B. CONSENT CALENDAR-COMMUNITY SERVICES DISTRICT**

B.1. MINUTES - SPECIAL CLOSED SESSION OF NOV. 13, 2018 (See A.1)

**Recommendation:** Approve as submitted.

B.2. MINUTES - SPECIAL MEETING OF NOV. 13, 2018 (See A.2)

**Recommendation:** Approve as submitted.

B.3. MINUTES - SPECIAL MEETING OF NOV. 19, 2018 (See A.3)

**Recommendation:** Approve as submitted.

**C. CONSENT CALENDAR - HOUSING AUTHORITY**

C.1. MINUTES - SPECIAL CLOSED SESSION OF NOV. 13, 2018 (See A.1)

**Recommendation:** Approve as submitted.

C.2. MINUTES - SPECIAL MEETING OF NOV. 13, 2018 (See A.2)

**Recommendation:** Approve as submitted.

Minutes Acceptance: Minutes of Dec 11, 2018 6:00 PM (CONSENT CALENDAR-CITY COUNCIL)

C.3. MINUTES - SPECIAL MEETING OF NOV. 19, 2018 (See A.3)

**Recommendation:** Approve as submitted.

**D. CONSENT CALENDAR - BOARD OF LIBRARY TRUSTEES**

D.1. MINUTES - SPECIAL CLOSED SESSION OF NOV. 13, 2018 (See A.1)

**Recommendation:** Approve as submitted.

D.2. MINUTES - SPECIAL MEETING OF NOV. 13, 2018 (See A.2)

**Recommendation:** Approve as submitted.

D.3. MINUTES - SPECIAL MEETING OF NOV. 19, 2018 (See A.3)

**Recommendation:** Approve as submitted.

**E. PUBLIC HEARINGS**

E.1. PROPOSED GENERAL PLAN AMENDMENT FOR PROJECTS 1 AND 2; PROJECT 1, CENTERPOINTE COMMERCE CENTER, INCLUDING A CHANGE OF ZONE AND PLOT PLAN FOR THE DEVELOPMENT OF A 204,022 SQUARE FOOT WAREHOUSE PROJECT ON 8.8 ACRES; AND PROJECT 2, BRODIAEA RESIDENTIAL PROJECT, INCLUDING A CHANGE OF ZONE, AND TENTATIVE TRACT MAP FOR 45 SINGLE-FAMILY RESIDENTIAL LOTS ON APPROXIMATELY 8.85 ACRES (RESO NOS. 2018-85 - 89 AND ORD NOS. 947-948 (Report of: Community Development)

Senior Planner Ormsby provided the report for Project 1.

Council Member Cabrera questioned whether the developer had secured a tenant for the project.

Jackson Smith, with Newcastle Partners, replied that currently no building occupant has been obtained.

Council Member Marquez queried if the developer has any other projects in the City.

Mr. Smith remarked that the current project, if approved, would be his first venture in Moreno Valley.

Mayor Gutierrez opened the Public Hearing at 8:41 pm.

Mr. Smith provided details of the project.

The following people spoke in support of the project: Rafael Brugueras and Louise Palomares.

There being no further comments in support or opposition, Mayor Gutierrez closed the Public Hearing at 8:49 pm.

Senior Planner Ormsby provided the report for Project 2.

Council Member Thornton asked if support or opposition for the project was received at the Planning Commission meeting and whether or not a traffic impact study was conducted.

Senior Planner Ormsby responded that one speaker spoke in favor of the project and confirmed that a traffic analysis was performed.

Mayor Gutierrez opened the Public Hearing at 8:54 pm.

There being no comments in support or opposition, Mayor Gutierrez closed the Public Hearing at 8:54 pm.

Council Member Marquez requested information regarding the developer's campaign contributions.

Melissa with Frontier stated she was unaware if any contributions were made.

**Recommendations: That the City Council:**

1. **CONDUCT** a public hearing for review of Project 1 and defer taking action on Project 1 until after the public hearing for Project 2; and
2. **CONDUCT** a public hearing for review of Project 2, then take action on Project 1 and Project 2; and
3. **ADOPT** Resolution No. 2018-85; A Resolution of the City Council of the City Moreno Valley for Project 1 **CERTIFYING** the Final Mitigated Negative Declaration (MND, PEN18-0026) prepared for the Centerpointe Commerce Center Project, inclusive of all related applications on file with the Community Development Department, incorporated herein by this reference, whereby the Final MND has been completed in compliance with the California Environmental Quality Act and reflects the City's independent judgement and analysis; and **ADOPTING** the Mitigation Monitoring and Reporting Program prepared for the Centerpointe Commerce Center project; and

**RESULT:** APPROVED [UNANIMOUS]  
**MOVER:** Victoria Baca, Mayor Pro Tem  
**SECONDER:** Ulises Cabrera, Council Member  
**AYES:** Dr. Yxstian A. Gutierrez, Victoria Baca, David Marquez, Ulises Cabrera, Dr. Carla J. Thornton

- 4. **ADOPT** Resolution No. 2018-86; A Resolution of the City Council of the City Moreno Valley for Project 2 **CERTIFYING** the Final Mitigated Negative Declaration (MND, PEN18-0055) prepared for the Brodiaea Residential Project inclusive of all related applications on file with the Community Development Department, incorporated herein by this reference, whereby the Final MND has been completed in compliance with the California Environmental Quality Act and reflects the City's independent judgement and analysis; and **ADOPTING** the Mitigation Monitoring and Reporting Program prepared for the Brodiaea Residential Project; and

**RESULT:** APPROVED [3 TO 1]  
**MOVER:** Victoria Baca, Mayor Pro Tem  
**SECONDER:** Dr. Yxstian A. Gutierrez, Mayor  
**AYES:** Dr. Yxstian A. Gutierrez, Victoria Baca, Ulises Cabrera  
**NAYS:** David Marquez  
**ABSTAIN:** Dr. Carla J. Thornton

- 5. **APPROVE** Resolution No. 2018-87, A Resolution of the City of Moreno Valley approving a General Plan Amendment thereby establishing General Plan designations for Project 1 and Project 2, as described in the Resolution and included on the revised General Plan Land Use Maps; and,

**RESULT:** APPROVED [4 TO 0]  
**MOVER:** Victoria Baca, Mayor Pro Tem  
**SECONDER:** David Marquez, Council Member  
**AYES:** Dr. Yxstian A. Gutierrez, Victoria Baca, David Marquez, Ulises Cabrera  
**ABSTAIN:** Dr. Carla J. Thornton

- 6. **INTRODUCE** and conduct the first reading by title only of Ordinance No. 947 approving a Zone Change (PEN18-0025) for Project 1 from Office (O) to Light Industrial (LI), based on the findings in the Ordinance, and the revised Zoning Atlas; and
- 8. **SCHEDULE** the introduced Ordinance for the second reading and final action for the next regular City Council meeting.

Minutes Acceptance: Minutes of Dec 11, 2018 6:00 PM (CONSENT CALENDAR-CITY COUNCIL)

**RESULT:** APPROVED [UNANIMOUS]  
**MOVER:** David Marquez, Council Member  
**SECONDER:** Ulises Cabrera, Council Member  
**AYES:** Dr. Yxstian A. Gutierrez, Victoria Baca, David Marquez, Ulises Cabrera, Dr. Carla J. Thornton

- 7. **APPROVE** Resolution No. 2018-88: A Resolution of the City Council of the City of Moreno Valley approving Plot Plan PEN18-0023 for Project 1 based on the findings contained in this resolution, and subject to the conditions of approval included as Exhibit A; and

**RESULT:** APPROVED [UNANIMOUS]  
**MOVER:** Victoria Baca, Mayor Pro Tem  
**SECONDER:** David Marquez, Council Member  
**AYES:** Dr. Yxstian A. Gutierrez, Victoria Baca, David Marquez, Ulises Cabrera, Dr. Carla J. Thornton

- 9. **INTRODUCE** and conduct the first reading by title only of Ordinance No. 948 approving a Change of Zone (PEN18-0054) for Project 2 from R3 (maximum 3 units/acre) to RS10 (single-family residential, maximum 10 units/acre) based on the findings in the Ordinance, and the revised Zoning Atlas; and

- 11. **SCHEDULE** the introduced Ordinance for the second reading and final action for the next regular City Council meeting.

**RESULT:** APPROVED [4 TO 1]  
**MOVER:** Victoria Baca, Mayor Pro Tem  
**SECONDER:** Dr. Yxstian A. Gutierrez, Mayor  
**AYES:** Dr. Yxstian A. Gutierrez, Victoria Baca, Ulises Cabrera, Dr. Carla J. Thornton  
**NAYS:** David Marquez

- 10. **APPROVE** Resolution No. 2018-89: A Resolution of the City Council of the City of Moreno Valley approving a Tentative Tract Map (PEN18-0092) for Project 2 based on the findings contained in this resolution, and subject to the conditions of approval included as Exhibit A; and

**RESULT:** APPROVED [4 TO 1]  
**MOVER:** Victoria Baca, Mayor Pro Tem  
**SECONDER:** Dr. Yxstian A. Gutierrez, Mayor  
**AYES:** Dr. Yxstian A. Gutierrez, Victoria Baca, Ulises Cabrera, Dr. Carla J. Thornton  
**NAYS:** David Marquez

Minutes Acceptance: Minutes of Dec 11, 2018 6:00 PM (CONSENT CALENDAR-CITY COUNCIL)



- E.2. A GENERAL PLAN AMENDMENT, CHANGE OF ZONE, AND CONDITIONAL USE PERMIT FOR DEVELOPMENT OF A DONUT STORE / CONVENIENCE STORE WITH GASOLINE SALES AND CAR WASH LOCATED AT THE NORTHEAST CORNER OF PERRIS BOULEVARD AND COTTONWOOD AVENUE (Report of: Community Development)

Associate Planner Bradshaw provided the report.

Mayor Gutierrez questioned how much potential sales tax revenue could be realized from the project.

Lincoln Watase, President of Yum Yum Donuts remarked that his projections indicate proceeds anywhere from \$160,000 to \$180,000.

Mayor Gutierrez opened the Public Hearing at 9:09 p.m.

Lincoln Watase

Mr. Watase of Yum Yum Donuts provided details of the project.

The following people spoke in opposition of the project: Theresa Archuleta, and Kathleen Dale.

The following people spoke in support of the project: Pete Bleckert, Roy Bleckert, Ruben Galvez, Jorge Herrera, Rafael Brugueras, and Louise Palomarez.

Lincoln Watase - rebuttal

Mr. Watase of Yum Yum Donuts provided additional details of the project.

There being no further comments in support or opposition, Mayor Gutierrez closed the Public Hearing at 9:38 p.m.

Mayor Pro Tem Baca expressed her support of the project.

Council Member Marquez communicated his opposition to the project.

Council Member Cabrera inquired as to the amount of wages Mr. Watase's employees earn.

Mr. Watase of Yum Yum Donuts responded that employees may earn \$14 an hour.

Council Member Cabrera queried whether Mr. Watase would formally guarantee the wage.

To which Mr. Watase agreed.

Council Member Cabrera questioned whether lighting would be fixed on the rear of the building.

Mayor Gutierrez noted that design requests should be made prior to the Council Meeting.

Ahmad Ghaderi, with A & S Engineering, stated that rear lighting is included in the building design.

Council Member Cabrera, after receiving confirmation from staff that a cannabis application was submitted for an adjacent lot, requested that the applicant consider prohibiting the sale of tobacco and alcohol products.

Mayor Gutierrez apologized to the applicant for the previous remarks and voiced his support of the project. He called into question whether the wage requirement was enforceable.

City Attorney Koczanowicz advised the City Council, should they wish to introduce a minimum wage, to consider an ordinance establishing a city wide base rather than setting individual rates.

**Recommendations: That the City Council:**

1. ADOPT Resolution No. 2018-90: A Resolution of the City Council of the City of Moreno Valley CERTIFYING the Mitigated Negative Declaration prepared for the Yum Yum Donuts Moreno Valley project, inclusive of all related applications on file with the Community Development Department, incorporated herein by this reference, whereby the Mitigated Negative Declaration has been completed in compliance with the California Environmental Quality Act, and the information and findings contained in the Mitigated Negative Declaration reflects the City’s independent judgment and analysis; and ADOPTING the Mitigation Monitoring and Reporting Program prepared for the Yum Yum Donuts Moreno Valley project; and

|                  |  |
|------------------|--|
| <b>RESULT:</b>   | <b>APPROVED [3 TO 2]</b>                                       |
| <b>MOVER:</b>    | Victoria Baca, Mayor Pro Tem                                   |
| <b>SECONDER:</b> | Dr. Yxstian A. Gutierrez, Mayor                                |
| <b>AYES:</b>     | Dr. Yxstian A. Gutierrez, Victoria Baca, Dr. Carla J. Thornton |
| <b>NAYS:</b>     | David Marquez, Ulises Cabrera                                  |

3. INTRODUCE and conduct the first reading by title only of Ordinance No. 949 approving the request of Yum Yum Donuts for a Zone Change (PEN16-0087) from Office Commercial (OC) to Community Commercial (CC) for a 1.77-acre site located at the northeast corner of Perris Boulevard and Cottonwood Avenue, as described in the Ordinance, based on the findings in the Ordinance, and the revised Zoning Atlas; and

Minutes Acceptance: Minutes of Dec 11, 2018 6:00 PM (CONSENT CALENDAR-CITY COUNCIL)

5. SCHEDULE the introduced Ordinance for second reading and final action for the next regular City Council meeting.

**RESULT:** APPROVED [3 TO 2]  
**MOVER:** Victoria Baca, Mayor Pro Tem  
**SECONDER:** Dr. Carla J. Thornton  
**AYES:** Dr. Yxstian A. Gutierrez, Victoria Baca, Dr. Carla J. Thornton  
**NAYS:** David Marquez, Ulises Cabrera

2. ADOPT Resolution No. 2018-91 approving the request by Yum Yum Donuts for a General Plan Amendment (PEN16-0086), from Residential/Office (R/O) to Commercial (C) for a 1.77-acre site located at the northeast corner of Perris Boulevard and Cottonwood Avenue, based on the findings in the Resolution, the Revised General Plan Land Use Map; and
4. ADOPT Resolution No. 2018-92: A Resolution of the City Council of the City of Moreno Valley approving the request of Yum Yum Donuts for a Conditional Use Permit PEN16-0088 for a convenience store with gasoline sales, carwash, and alcohol beer and wine sales for a 1.77-acre site located at the northeast corner of Perris Boulevard and Cottonwood Avenue, based on the findings contained in this Resolution, and subject to the conditions of approval included as Exhibit A; and

**RESULT:** APPROVED [3 TO 2]  
**MOVER:** Victoria Baca, Mayor Pro Tem  
**SECONDER:** Dr. Carla J. Thornton  
**AYES:** Dr. Yxstian A. Gutierrez, Victoria Baca, Dr. Carla J. Thornton  
**NAYS:** David Marquez, Ulises Cabrera

#### **F. ITEMS REMOVED FROM CONSENT CALENDARS FOR DISCUSSION OR SEPARATE ACTION – NONE**

Mayor Gutierrez recessed the City Council meeting at 9:57 p.m.

Mayor Gutierrez reconvened the City Council meeting at 10:06 p.m.

#### **G. GENERAL BUSINESS**

- G.1. CONSIDERATION OF CHANGING THE NUMBER OF COMMERCIAL CANNABIS BUSINESS PERMITS ALLOWED IN THE CITY (Report of: Financial & Management Services)

Chief Financial Officer/City Treasurer Eyerman provided the report.

Mayor Gutierrez requested clarification regarding the three permit options presented.

Chief Financial Officer/City Treasurer Eyerman explained the differences and the procedures an applicant would follow respective to each option.

City Manager DeSantis announced that changing the number of permits does not necessarily change the number of businesses operating in the City. At the request of Mayor Gutierrez, City Manager DeSantis responded that the City of Perris, which set no numeric limit on recreational cannabis permits, have two to three legal cannabis businesses in operation.

Council Member Cabrera wanted to ascertain what types of services the revenue could fund.

Chief Financial Officer/City Treasurer Eyerman responded with examples.

Council Member Marquez questioned why the City Council is deliberating the issuance of additional fees when it was already decided that they would be awarded through a lottery.

City Manager DeSantis remarked that the City Council is being presented with additional options to decide if the program requires refinement.

Council Member Marquez suggested an alternative for the Council to adopt.

City Manager DeSantis stated that the Council has the discretion to revise the policy as they see fit, but the options introduced were determined by staff to be the best options available.

City Attorney Koczanowicz added that the lotto was instituted because an excess of vetted applicants arose.

Community Development Director Sandzimier interjected that officials in Denver reported amending their ordinance eleven times.

Mayor Pro Tem Baca questioned what procedural changes would occur if the number of permits were increased.

Chief Financial Officer/City Treasurer Eyerman provided the details.

City Attorney Koczanowicz provided additional information.

Mayor Gutierrez recommended option A, allowing the fifteen dispensary applicants not chosen in the lottery, to continue the process.

City Attorney Koczanowicz interjected that it also included the micro business permits.

Council Member Thornton recommended option A, with the caveat that a time limit be included to obtain a conditional use permit.

City Attorney Koczanowicz responded that if a majority of the City Council agrees, they could take action on the permits as they are and staff would return with a revised resolution amending the initial application rules.

Council Member Marquez proposed an alternative option.

Mayor Pro Tem Baca communicated her desire to make permits available to all qualified applicants.

Council Member Cabrera voiced his support for option A.

**Recommendation: That the City Council:**

- 1. Consider a change in the maximum number of Commercial Cannabis Business Permits that would be issued in the City.

Option A

|                  |   |
|------------------|---|
| <b>RESULT:</b>   | <b>APPROVED [3 TO 2]</b>  |
| <b>MOVER:</b>    | Dr. Carla J. Thornton   |
| <b>SECONDER:</b> | Dr. Yxstian A. Gutierrez, Mayor                                 |
| <b>AYES:</b>     | Dr. Yxstian A. Gutierrez, Ulises Cabrera, Dr. Carla J. Thornton |
| <b>NAYS:</b>     | Victoria Baca, David Marquez                                    |

**H. REPORTS**

**H.1. CITY COUNCIL REPORTS**

(Informational Oral Presentation - not for Council action)

March Joint Powers Commission (JPC) - Mayor Pro Tem Baca

Mayor Pro Tem Baca reported the following:

Tonight, I'm providing an update from the March Joint Powers Commission meeting on November 14<sup>th</sup>.

At that meeting, the Commission authorized JPA staff to advertise a Request for Proposals for a comprehensive General Plan Update. We also approved a Foreign Trade Zone subzone to activate one million square feet in two facilities in Eastvale and Mira Loma.

Riverside County Habitat Conservation Agency (RCHCA) - None

Riverside County Transportation Commission (RCTC) - None

Riverside Transit Agency (RTA) - Council Member Marquez

Council Member Marquez reported the following:

Once again, RTA will be offering a Youth Fare promotion during the winter break. From December 21 through January 13, students in grades 1-12 can ride the bus for only 25 cents. This fare promotion is good for any fixed route bus including commuter links. Just show your student ID.

Western Riverside Council of Governments (WRCOG) - None

Western Riverside County Regional Conservation Authority (RCA) - Mayor Pro Tem Baca

Mayor Pro Tem Baca reported the following:

Items covered at the RCA Board of Directors meeting on December 3, 2018 include:

- The October 2018 MSHCP Fee Collection Report for Moreno Valley indicates that approximately \$61,000 was collected for 29 residential permits.

School District/City Joint Task Force - None

## **H.2. CITY MANAGER'S REPORT**

(Informational Oral Presentation - not for Council action)

City Manager DeSantis congratulated the elected and reelected Council Members.

## **H.3. CITY ATTORNEY'S REPORT**

(Informational Oral Presentation - not for Council action)

City Attorney Koczanowicz agreed with the sentiments of City Manager DeSantis

**CLOSING COMMENTS AND/OR REPORTS OF THE CITY COUNCIL, COMMUNITY SERVICES DISTRICT, CITY AS SUCCESSOR AGENCY FOR THE COMMUNITY REDEVELOPMENT AGENCY, HOUSING AUTHORITY AND THE BOARD OF LIBRARY TRUSTEES.**

Council Member Thornton

1. Expressed her gratitude and humility for the opportunity to serve the City.

Council Member Marquez

1. Applauded the newly elected and reelected candidates.
2. Rooted for the Los Angeles Rams.

Council Member Cabrera

1. Welcomed Dr. Thornton.
2. Requested and received support for an item to investigate increasing the noticing requirement for Public Hearing items and an item identifying safe areas for semi-truck parking.

Mayor Pro Tem Baca

1. Pleased that the Registrar of Voters certified the election.
2. Commended the incoming and reelected Council members.
3. Noted that the applicant withdrew his application for a gas station on Moreno Beach Drive.
4. Requested and received support for an examination of zoning options for cannabis.

Mayor Gutierrez

1. Thanked all who attended the swearing in ceremony.

**ADJOURNMENT**

There being no further business to come before the City Council, Mayor Gutierrez adjourned the meeting in memory of Gerald Michael Budlong at 10:52 p.m.

Submitted by:

---

Pat Jacquez-Nares, CMC & CERA  
 City Clerk  
 Secretary, Moreno Valley Community Services District  
 Secretary, City as Successor Agency for the Community  
 Redevelopment Agency of the City of Moreno Valley  
 Secretary, Moreno Valley Housing Authority  
 Secretary, Board of Library Trustees

Approved by:

---

Dr. Yxstian A. Gutierrez  
 Mayor  
 City of Moreno Valley  
 President, Moreno Valley Community Services District  
 Chairperson, City as Successor Agency for the Community  
 Redevelopment Agency of the City of Moreno Valley  
 Chairperson, Moreno Valley Housing Authority  
 Chairperson, Board of Library Trustees



**MINUTES  
JOINT MEETING OF THE  
CITY COUNCIL OF THE CITY OF MORENO VALLEY  
MORENO VALLEY COMMUNITY SERVICES DISTRICT  
CITY AS SUCCESSOR AGENCY FOR THE  
COMMUNITY REDEVELOPMENT AGENCY OF THE  
CITY OF MORENO VALLEY  
MORENO VALLEY HOUSING AUTHORITY  
BOARD OF LIBRARY TRUSTEES**

**CLOSED SESSION – 4:30 PM  
December 18, 2018**

**CALL TO ORDER**

The Closed Session of the City Council of the City of Moreno Valley, Moreno Valley Community Services District, City as Successor Agency for the Community Redevelopment Agency of the City of Moreno Valley, and Housing Authority was called to order at 4:30 p.m. by Mayor Gutierrez in the Council Chamber located at 14177 Frederick Street, Moreno Valley, California.

Mayor Gutierrez announced that the City Council receives a separate stipend for CSD meetings.

**ROLL CALL**

Council Member Cabrera arrived at 4:35 p.m.

|          |                          |                |
|----------|--------------------------|----------------|
| Council: | Dr. Yxstian A. Gutierrez | Mayor          |
|          | Victoria Baca            | Mayor Pro Tem  |
|          | Ulises Cabrera           | Council Member |
|          | Dr. Carla J. Thornton    | Council Member |

|         |               |                |
|---------|---------------|----------------|
| Absent: | David Marquez | Council Member |
|---------|---------------|----------------|

**PUBLIC COMMENTS ON MATTERS ON THE AGENDA ONLY**

Mayor Gutierrez opened the public comments portion of the meeting for items listed on the agenda only. There being no members of the public to come forward to speak, he closed the public comments.

**CLOSED SESSION**

City Attorney Koczanowicz announced that the City Council would recess to Closed Session to discuss the items as listed on the agenda and that staff did not anticipate any reportable action.

Minutes Acceptance: Minutes of Dec 18, 2018 4:30 PM (CONSENT CALENDAR-CITY COUNCIL)

The Closed Session will be held pursuant to Government Code:

1 SECTION 54956.8 - CONFERENCE WITH REAL PROPERTY NEGOTIATOR

- a) Property APN's: 291-191-027  
 291-191-028  
 291-191-029  
 291-191-026  
 291-191-025  
 291-191-007  
 291-191-008  
 291-191-009  
 291-191-010  
 291-191-011  
 291-191-012  
 291-191-013
- City Negotiator: Thomas DeSantis
- Other Party: Unknown at this Time
- Under Negotiation: Price, Terms and Conditions

2 SECTION 54956.8 - CONFERENCE WITH REAL PROPERTY NEGOTIATOR

- a) Property APN's: 486-280-044  
 486-280-059
- City Negotiator: Thomas DeSantis  
 Allen Brock  
 Mike Lee
- Negotiating Party: Panorama Properties
- Under Negotiation: Price and Terms of Payment

3 Potential Litigation Government Code Section 54956.9(d)(2)

4 SECTION 54957.6 - LABOR NEGOTIATIONS

- a) Agency Representative: Thomas M. DeSantis, City Manager
- Employee Organization: Moreno Valley City Employees Association (MVCEA)
- b) Agency Representative: Thomas M. DeSantis, City Manager
- Employee Organization: Moreno Valley Management Association (MVMA)

Mayor Gutierrez recessed the Council to the City Manager's Conference Room, second floor, City Hall, for their Closed Session at 4:32 p.m.

Minutes Acceptance: Minutes of Dec 18, 2018 4:30 PM (CONSENT CALENDAR-CITY COUNCIL)

Mayor Gutierrez reconvened the City Council in the Council Chamber from their Closed Session at 5:41 p.m.

#### **REPORT OF ACTION FROM CLOSED SESSION, IF ANY, BY CITY ATTORNEY**

City Attorney Koczanowicz announced there was no reportable action taken in Closed Session.

#### **ADJOURNMENT**

There being no further business to come before the City Council, Mayor Gutierrez adjourned the Closed Session at 5:42 p.m.

**MINUTES**  
**CITY COUNCIL REGULAR MEETING OF THE CITY OF MORENO VALLEY**  
**December 18, 2018**

**CALL TO ORDER - 5:30 PM**

**SPECIAL PRESENTATIONS**

1. Business Spotlights
  - a) Moss Bros. Auto Mall
  - b) La Bamba Pupuseria
2. Presentation Recognizing the City of Moreno Valley Employee of the Third Quarter, LaSonja Nelson

**MINUTES  
JOINT MEETING OF THE  
CITY COUNCIL OF THE CITY OF MORENO VALLEY  
MORENO VALLEY COMMUNITY SERVICES DISTRICT  
CITY AS SUCCESSOR AGENCY FOR THE  
COMMUNITY REDEVELOPMENT AGENCY OF THE  
CITY OF MORENO VALLEY  
MORENO VALLEY HOUSING AUTHORITY  
BOARD OF LIBRARY TRUSTEES**

**REGULAR MEETING – 6:00 PM  
December 18, 2018**

**CALL TO ORDER**

The Joint Meeting of the City Council, Community Services District, City as Successor Agency for the Community Redevelopment Agency of the City of Moreno Valley, Moreno Valley Housing Authority and the Board of Library Trustees was called to order at 6:51 p.m. by Mayor Gutierrez in the Council Chamber located at 14177 Frederick Street.

**PLEDGE OF ALLEGIANCE**

The Pledge of Allegiance was led by Rafael Brugueras.

**INVOCATION**

Pastor Melvin Thomas, Praise and Worship Center

**ROLL CALL**

|          |                          |                |
|----------|--------------------------|----------------|
| Council: | Dr. Yxstian A. Gutierrez | Mayor          |
|          | Victoria Baca            | Mayor Pro Tem  |
|          | Dr. Carla J. Thornton    | Council Member |
|          | Ulises Cabrera           | Council Member |

|         |               |                |
|---------|---------------|----------------|
| Absent: | David Marquez | Council Member |
|---------|---------------|----------------|

**INTRODUCTIONS**

|        |                    |   |
|--------|--------------------|---|
| Staff: | Pat Jacquez-Nares  | City Clerk  |
|        | Angel Migao        | Executive Assistant to the Mayor and City Council |
|        | Marshall Eyerman   | Chief Financial Officer/City Treasurer            |
|        | Martin Koczanowicz | City Attorney                                     |
|        | Tom DeSantis       | City Manager                                      |

Minutes Acceptance: Minutes of Dec 18, 2018 6:00 PM (CONSENT CALENDAR-CITY COUNCIL)

|                  |                                       |
|------------------|---------------------------------------|
| Allen Brock      | Assistant City Manager                |
| Mike Lee         | Economic Development Director         |
| Rick Sandzimier  | Community Development Director        |
| David Kurylowicz | Chief of Police                       |
| Abdul Ahmad      | Fire Chief                            |
| Kathleen Sanchez | Human Resources Director              |
| Patti Solano     | Parks and Community Services Director |
| Michael Wolfe    | Public Works Director/City Engineer   |

## **PUBLIC COMMENTS ON ANY SUBJECT NOT ON THE AGENDA UNDER THE JURISDICTION OF THE CITY COUNCIL**

### Robert Harris

1. Welcomed Council Member Thornton.
2. Thanked City staff for all they've accomplished.

### Wendell Antoine

1. Opposes the construction of an Arco Gas Station.

Mayor Gutierrez remarked that the item will be deliberated on February 19, 2018.

### Jorge Quintero

1. Congratulated the reelected and new Council Members.
2. Asked that the City contact the School District to reschedule the meetings so that they don't conflict.

### Jose Chavez

1. Expressed his support of Mayor Gutierrez.
2. Wished everyone a Merry Christmas and Happy New Year.

### Rafael Brugueras

1. Provided a report on the legalization of CBD to the City Council members.

### Louise Palomarez

1. Congratulated the reelected and newly elected Council Members.
2. Conveyed her appreciation for the City Council.

### Roy Bleckert

1. Communicated his hope that the meetings are organized in a way that welcomes differing opinions.

## **JOINT CONSENT CALENDARS (SECTIONS A-D)**

Mayor Gutierrez opened the Consent Agenda items for public comments, were received from Rafael Brugueras (Supports Item Nos. A.2, A.4, A.5, A.6, A.7, A.8, and A.9) and Roy Bleckert (Supports Item Nos. A.7.).

**RESULT:** APPROVED [UNANIMOUS]  
**MOVER:** Victoria Baca, Mayor Pro Tem  
**SECONDER:** Dr. Carla J. Thornton, Council Member  
**AYES:** Dr. Yxstian A. Gutierrez, Victoria Baca, Ulises Cabrera, Dr. Carla J. Thornton  
**ABSENT:** David Marquez

## A. CONSENT CALENDAR-CITY COUNCIL

- A.1. ORDINANCES - READING BY TITLE ONLY - THE MOTION TO ADOPT AN ORDINANCE LISTED ON THE CONSENT CALENDAR INCLUDES WAIVER OF FULL READING OF THE ORDINANCE.

**Recommendation:** Waive reading of all Ordinances.

- A.2. PAYMENT REGISTER - OCTOBER 2018 (Report of: Financial & Management Services)

**Recommendation:**

1. Receive and file the Payment Register.

- A.3. RESOLUTION OF THE CITY OF MORENO VALLEY SERVING AS THE SUCCESSOR AGENCY TO THE COMMUNITY REDEVELOPMENT AGENCY OF THE CITY OF MORENO VALLEY APPROVING THE RECOGNIZED OBLIGATION PAYMENT SCHEDULE AND ADMINISTRATIVE BUDGET FOR THE PERIOD OF JULY 1, 2019 THROUGH JUNE 30, 2020 (ROPS 19-20) (Report of: Financial & Management Services)

**Recommendations: That the City Council as Successor Agency:**

1. Adopt Resolution No. SA 2018-06. A Resolution of the City Council of the City of Moreno Valley, California, Serving as Successor Agency to the Community Redevelopment Agency of the City of Moreno Valley Approving the Recognized Obligation Payment Schedule and Administrative Budget for the Period of July 1, 2019 through June 30, 2020 (ROPS 19-20), and Authorizing the City Manager acting for the Successor Agency or his/her Designee to Make Modifications Thereto.
2. Authorize the City Manager acting for the Successor Agency or her Designee to make modifications to the Schedule.
3. Authorize the transmittal of the ROPS 19-20, for the period of July 1, 2019 through June 30, 2020, including Administrative Budget for the said period, ("Exhibit A") to the Countywide Oversight Board for County of Riverside for review and approval.

- A.4. SECOND READING AND CONSIDERATION OF ADOPTION OF ORDINANCE NO. 944 AMENDING CHAPTER 5.05 COMMERCIAL CANNABIS REGULATIONS AND ORDINANCE NO. 945 AMENDING CHAPTER 9.09 RELATED TO COMMERCIAL CANNABIS BUSINESSES CONDITIONAL USE PERMITS (Report of: Financial & Management Services)

**Recommendation: That the City Council:**

1. Adopt Ordinance No. 944 amending Chapter 5.05 Commercial Cannabis Regulations and Ordinance No. 945 amending Chapter 9.09 related to Commercial Cannabis Business Condition Use Permits.

- A.5. ADOPTION OF RESOLUTION 2018-93 AMENDING THE APPLICATION PROCESSES FOR COMMERCIAL CANNABIS BUSINESS PERMITS (Reso No. 2018-93) (Report of: Financial & Management Services)

**Recommendation: That the City Council:**

1. Adopt Resolution 2018-93, amending the Application Processes for Commercial Cannabis Business Permits.

- A.6. AWARD TO CHASTANG FORD, HAAKER EQUIPMENT COMPANY, AND ALTEC INDUSTRIES FOR THE PURCHASE OF ELEVEN VEHICLES (Report of: Public Works)

**Recommendations:**

1. Award to Chastang Ford, Houston, TX, for the purchase of nine vehicles as follows: two 2019 Ford F550 Standard Cab Chassis with Sign Maintenance Body; one 2019 Ford F550 Standard Cab Chassis with Stencil Body; one 2019 Ford F550 Standard Cab Chassis with Stake Bed; two 2019 Ford F550 Crew Cab Chassis with Stake Bed; one 2019 Ford F550 Crew Cab Chassis with Concrete Service Body; one 2019 Ford F550 with Mechanic's Service Body; and one 2019 F750 Standard Cab Chassis with Water Truck Body, and;
2. Authorize the Purchasing & Facilities Division Manager to issue a purchase order to Chastang Ford in the amount of \$757,442.00 plus an estimated sales and use tax amount of \$53,020.94 for a total amount of \$810,462.94.
3. Award to Haaker Equipment Company, for the purchase of one 2019 Freightliner Chassis with an Elgin CNG Broom Bear Street Sweeper, and;
4. Authorize the Purchasing & Facilities Division Manager to issue a



purchase order to Haaker Equipment Company in the amount of \$390,465.33 plus an estimated sales and use tax amount of \$27,332.57 for a total amount of \$417,797.90.

5. Award to Altec Industries, Inc. for the purchase of one 2019 Ford F550 Chassis with an Altec AT41M Articulating Aerial Lift body, and;
6. Authorize the Purchasing & Facilities Division Manager to issue a purchase order to Altec Industries, Inc. in the amount of \$150,599.00 plus an estimated sales and use tax amount of \$10,541.93 for a total amount of \$161,140.93.

- A.7. SECOND READING AND CONSIDERATION OF ADOPTION OF ORDINANCE NO. 949 AUTHORIZING A CHANGE OF ZONE FOR THE PROPERTY LOCATED AT THE NORTHWEST CORNER OF PERRIS BOULEVARD AND COTTONWOOD AVENUE (Report of: Community Development)

**Recommendation:**

1. That the City Council conduct the second reading by title only and adopt Ordinance No. 949.

- A.8. Second Reading and consideration of Adoption of Ordinance No. 947 authorizing a Change of Zone for the property located at the northeast corner of Brodiaea Avenue and Frederick Street (Report of: Community Development)

**Recommendation:**

1. That the City Council conduct second reading by title only and adopt Ordinance No. 947

- A.9. Second Reading and consideration of Adoption of Ordinance No. 948 authorizing a Change of Zone for the property located at the northwest corner of Brodiaea Avenue and Quincy Street (Report of: Community Development)

**Recommendation:**

1. That the City Council conduct second reading by title only and Adopt Ordinance No. 948.

**B. CONSENT CALENDAR-COMMUNITY SERVICES DISTRICT**

- B.1. ORDINANCES - READING BY TITLE ONLY - THE MOTION TO ADOPT AN ORDINANCE LISTED ON THE CONSENT CALENDAR INCLUDES WAIVER OF FULL READING OF THE ORDINANCE.

**Recommendation:** Waive reading of all Ordinances.

### C. CONSENT CALENDAR - HOUSING AUTHORITY

- C.1. ORDINANCES - READING BY TITLE ONLY - THE MOTION TO ADOPT AN ORDINANCE LISTED ON THE CONSENT CALENDAR INCLUDES WAIVER OF FULL READING OF THE ORDINANCE.

**Recommendation:** Waive reading of all Ordinances.

### D. CONSENT CALENDAR - BOARD OF LIBRARY TRUSTEES

- D.1. ORDINANCES - READING BY TITLE ONLY - THE MOTION TO ADOPT AN ORDINANCE LISTED ON THE CONSENT CALENDAR INCLUDES WAIVER OF FULL READING OF THE ORDINANCE.

**Recommendation:** Waive reading of all Ordinances.

### E. PUBLIC HEARINGS

Questions or comments from the public on a Public Hearing matter are limited to five minutes per individual and must pertain to the subject under consideration.

Those wishing to speak should complete and submit a GOLDENROD speaker slip to the Sergeant-at-Arms.

- E.1. PUBLIC HEARING FOR THE ANNUAL ACTION PLAN FOR PROGRAM YEAR 2019-2020 & TO ADOPT OBJECTIVES AND POLICIES (Report of: Financial & Management Services)

Chief Financial Officer/City Treasurer Eyerman provided the report.

Council Member Cabrera queried when the non-profit workshop would take place.

Chief Financial Officer/City Treasurer Eyerman remarked that the application would be available online on December 20, 2018 and a citizen workshop is scheduled tentatively for January 10, 2019.

Mayor Gutierrez opened the Public Hearing at 6:37 p.m.

Rafael Brugueras supports Item No. E.1.

There being no further comments in support or opposition, Mayor Gutierrez closed the Public Hearing at 6:41 p.m.

Council Member Cabrera indicated his appreciation to Chief Financial Officer/City Treasurer Eyerman and his staff.

**Recommendations: That the City Council:**

- 1. Conduct a Public Hearing to allow for the public to comment on the needs of low-and-moderate income residents in Moreno Valley.
- 2. Approve the proposed CDBG, HOME, and ESG Grant Objectives and Policies for the 2019-2020 Program Year.

|                  |  |
|------------------|--|
| <b>RESULT:</b>   | <b>APPROVED [UNANIMOUS]</b>  |
| <b>MOVER:</b>    | Victoria Baca, Mayor Pro Tem   |
| <b>SECONDER:</b> | Dr. Carla J. Thornton, Council Member  |
| <b>AYES:</b>     | Dr. Yxstian A. Gutierrez, Victoria Baca, Ulises Cabrera, Dr. Carla J. Thornton |
| <b>ABSENT:</b>   | David Marquez  |

**F. ITEMS REMOVED FROM CONSENT CALENDARS FOR DISCUSSION OR SEPARATE ACTION - NONE**

**G. GENERAL BUSINESS**

G.1. City Council Reorganization - Selection of Mayor Pro Tem (Report of: City Clerk)

Mayor Gutierrez explained the duties of the Mayor Pro Tem and indicated his appreciation of the work performed by Mayor Pro Tem Baca.

City Clerk Jacquez-Nares provided the report.

Robert Harris

- 1. Supports Mayor Pro Tem Baca for reappointment.

Rafael Bruqueras

- 1. Supports Mayor Pro Tem Baca for reappointment.

Louise Palomarez

- 1. Supports Mayor Pro Tem Baca for reappointment.

Council Member Cabrera nominated Mayor Pro Tem Baca.

**Recommendation: That the City Council:**

- 1. Conduct the reorganization of the City Council by selecting one Council Member to serve a one-year term as Mayor Pro Tem.

Motion to Appoint Victoria Baca as Mayor Pro Tem.

Minutes Acceptance: Minutes of Dec 18, 2018 6:00 PM (CONSENT CALENDAR-CITY COUNCIL)

|                |  |
|----------------|--|
| <b>RESULT:</b> | <b>APPROVED [UNANIMOUS]</b>  |
| <b>MOVER:</b>  | Ulises Cabrera, Council Member   |
| <b>AYES:</b>   | Dr. Yxstian A. Gutierrez, Victoria Baca, Ulises Cabrera, Dr. Carla J. Thornton |
| <b>ABSENT:</b> | David Marquez  |

After taking her Oath Mayor Pro Tem Baca thanked staff and residents for their support.

## H. REPORTS

### H.1. CITY COUNCIL REPORTS

(Informational Oral Presentation - not for Council action)

March Joint Powers Commission (JPC) - Mayor Pro Tem Baca

Mayor Pro Tem Baca reported the following:

Tonight, I'm providing an update from the March Joint Powers Commission meeting on December 12<sup>th</sup>.

At that meeting, the Commission approved audit results for FY 2017/18 for

- the March Joint Powers Authority,
- the March Inland Port Airport Authority, and
- the March Joint Powers Utilities Authority.

We also said our goodbyes to Supervisor Marion Ashley upon his retirement and recognized his decades of service to the March Joint Powers Authority.

Riverside County Habitat Conservation Agency (RCHCA) - None

Riverside County Transportation Commission (RCTC) - None

Riverside Transit Agency (RTA) - None

Western Riverside Council of Governments (WRCOG) - None

Western Riverside County Regional Conservation Authority (RCA) - None

School District/City Joint Task Force - Mayor Pro Tem Baca

Mayor Pro Tem Baca reported the following:

The Joint Task Force met earlier today. In addition to the City, representatives from Moreno Valley Police Department, State of California Lake Perris, and Moreno Valley and Val Verde Unified School Districts attended the meeting.

The Moreno Valley Police Department reported that today, December 18, the Police Department's Student Resource Officers conducted a truancy sweep with only three students being detained. Also today, in conjunction with the Moreno Valley Fire Department, the Police Department hosted the Holiday Parade visiting children on approximately 50 streets throughout the city giving out candy and holiday cheer.

Other Police Department holiday activities included the Shop with a Cop event, which assisted 30 children, and the Holiday Cheer Program, which assisted 40 families.

The Parks and Community Services Department reported that the new SOARING Activity Guide is now available to residents to register for classes and programs including the Valley Kids Day Camps during the winter school districts' breaks. In addition, a new hashtag MoValParks has been assigned to promote awareness of the Department's events and programs.

The Moreno Valley Unified School District reported that the current graduation rate for the four Moreno Valley high schools is above 92%, which is a significant increase from the year 2010, when it was approximately 70%.

The State of California Lake Perris reported that the Moreno Valley Unified School District partnered with Empire Row and Lake Perris to offer middle and high school students access to the #1 recruited collegiate sport and one of the fastest growing sports in high school.

## **H.2. CITY MANAGER'S REPORT**

(Informational Oral Presentation - not for Council action)

Assistant City Manager Allen Brock provided an update on the Momentum Moval Strategic Plan.

Mayor Gutierrez thanked staff for moving the Moval Strategic Plan forward.

City Manager DeSantis remarked on the uniqueness of the City's Strategic Plan. He announced that a Study Session will be scheduled in the coming year to discuss the General Plan. He wished the City Council and residents a wonderful Christmas and Happy New Year.

### H.3. CITY ATTORNEY'S REPORT

(Informational Oral Presentation - not for Council action)

City Attorney Koczanowicz echoed the City Manager's sentiments.

### **CLOSING COMMENTS AND/OR REPORTS OF THE CITY COUNCIL, COMMUNITY SERVICES DISTRICT, CITY AS SUCCESSOR AGENCY FOR THE COMMUNITY REDEVELOPMENT AGENCY, HOUSING AUTHORITY AND THE BOARD OF LIBRARY TRUSTEES.**

#### Council Member Thornton

1. Thanked City staff and residents for their participation during the meeting.
2. Expressed her desire for Council Member Marquez to have been able to attend the meeting.
3. Congratulated Mayor Pro Tem Baca on her reappointment.
4. Wished everyone Happy Holidays.

#### Council Member Cabrera

1. Announced that the next Food Pantry would take place on January 5, 2019 and requested suggestions for a larger food storage space.
2. Reminded everyone that the Farmers Market is held every Thursday near the CRC.
3. Reflected on a productive year and maintained that the coming year would be just as constructive.
4. Mentioned that in 2028 Olympic events will be held at Lake Perris.
5. Wished everyone Happy Holidays.

#### Mayor Pro Tem Baca

1. Encouraged everyone to shop Moval.
2. Attended the Farmers Market and was delighted with the items available.
3. Stated that the conflict with the School District meeting was already resolved.
4. Thanked everyone for their support in her reappointment as Mayor Pro Tem.
5. Wished everyone Happy Holidays.

#### Mayor Gutierrez

1. Persuaded everyone to practice generosity.
2. Expressed his gratitude to the Police Department and Fire Department for their holiday toy drives.
3. Attended the successful Tree Lighting Ceremony.
4. Applauded Mayor Pro Tem Baca on her reappointment.
5. Commended Council Members Thornton and Cabrera on their election and reelection, respectively.
6. Wished residents and staff Happy Holidays.

## ADJOURNMENT

There being no further business to come before the City Council, Mayor Gutierrez adjourned the meeting at 7:17 p.m.

Submitted by:

---

Pat Jacquez-Nares, CMC & CERA  
 City Clerk  
 Secretary, Moreno Valley Community Services District  
 Secretary, City as Successor Agency for the Community  
 Redevelopment Agency of the City of Moreno Valley  
 Secretary, Moreno Valley Housing Authority  
 Secretary, Board of Library Trustees

Approved by:

---

Dr. Yxstian A. Gutierrez  
 Mayor  
 City of Moreno Valley  
 President, Moreno Valley Community Services District  
 Chairperson, City as Successor Agency for the Community  
 Redevelopment Agency of the City of Moreno Valley  
 Chairperson, Moreno Valley Housing Authority  
 Chairperson, Board of Library Trustees



## Report to City Council

---

**TO:** Mayor and City Council

**FROM:** Kathleen Sanchez, Human Resources Director

**AGENDA DATE:** January 15, 2019

**TITLE:** LIST OF PERSONNEL CHANGES

---

### **RECOMMENDED ACTION**

#### **Recommendation:**

1. Ratify the list of personnel changes as described.

### **DISCUSSION**

The attached list of personnel changes scheduled since the last City Council meeting is presented for City Council ratification.

Staffing of City positions ensures assignment of highly qualified and trained personnel to achieve Momentum MoVal priorities, objectives and initiatives.

### **FISCAL IMPACT**

All position changes are consistent with appropriations previously approved by the City Council.

### **PREPARATION OF STAFF REPORT**

Prepared By:  
Denise Hansen  
Executive Assistant

Department Head Approval:  
Kathleen M. Sanchez  
Human Resources Director

### **CITY COUNCIL GOALS**

None

### **CITY COUNCIL STRATEGIC PRIORITIES**



- 1. Economic Development
- 2. Public Safety
- 3. Library
- 4. Infrastructure
- 5. Beautification, Community Engagement, and Quality of Life
- 6. Youth Programs

**ATTACHMENTS**

- 1. Personnel Changes - 1.15.19

**APPROVALS**

|                         |                   |                  |
|-------------------------|-------------------|------------------|
| Budget Officer Approval | <u>✓ Approved</u> | 1/07/19 10:00 AM |
| City Attorney Approval  | <u>✓ Approved</u> | 1/03/19 2:01 PM  |
| City Manager Approval   | <u>✓ Approved</u> | 1/08/19 4:22 PM  |

**City of Moreno Valley  
Personnel Changes  
January 15, 2019**

**New Hires**

Raquel Ortega, Administrative Assistant  
Community Development Department/Code & Neighborhood Services Division

**Promotions**

Terry Klauminzer  
From: Senior Traffic Signal Technician, Public Works Department/Transportation Division  
To: Traffic Operations Supervisor, Public Works Department/Transportation Division

Regina Flores  
From: Deputy City Clerk, City Clerk's Office  
To: Senior Deputy City Clerk, City Clerk's Office

**Transfers**

None

**Separations**

Mark Gross, Senior Planner  
Community Development Department/Planning Division

Scott Duncan, Traffic Operations Supervisor  
Public Works Department/Transportation Division



## Report to City Council

---

**TO:** Mayor and City Council

**FROM:** Michael L. Wolfe, P.E., Public Works Director/City Engineer

**AGENDA DATE:** January 15, 2019

**TITLE:** PURSUANT TO A LANDOWNER PETITION, ANNEX THREE PARCELS INTO COMMUNITY FACILITIES DISTRICT NO. 2014-01 (MAINTENANCE SERVICES) - AMENDMENT NO. 31 (RESO. NO. 2019-\_\_)

---

### **RECOMMENDED ACTION**

#### **Recommendation:**

Acting as the legislative body of Community Facilities District No. 2014-01 (Maintenance Services), adopt Resolution No. 2019-\_\_, a Resolution of the City Council of the City of Moreno Valley, California, ordering the annexation of territory to City of Moreno Valley Community Facilities District No. 2014-01 (Maintenance Services) and approving the amended map for said District.

### **SUMMARY**

Approval of the proposed resolution(s) will certify annexation of three parcel(s) into Community Facilities District (CFD) No. 2014-01 (Maintenance Services) ("District"). This action impacts one property owner(s), not the general citizens or taxpayers of the City.

The City requires property owners of new development projects to mitigate the cost of certain impacts created by the proposed development (i.e., the cost of operation and maintenance of street lights and/or public landscaping). The City created CFD No. 2014-01 to provide the development community with a funding mechanism to assist in satisfying the requirement. After a property owner elects to annex their property into the District and the City Council approves the annexation, a special tax can be levied on the annual property tax bill(s) of the annexed parcel(s) to fund the costs.

As a condition of approval for development of their project(s), Duke Realty LTD Partnership (the "Property Owner") is required to provide a funding source for the

maintenance and operation of certain public improvements (i.e., street lighting and landscape maintenance services) and has elected to annex the parcel(s) of their project(s) into the District to satisfy the condition(s). The Property Owner has submitted a Landowner Petition approving the annexation and the City Clerk has confirmed the petition is valid.

## **DISCUSSION**

### *District Formation*

The District was formed by adoption of Resolution No. 2014-25 to provide an alternative funding tool for the development community. It provides a mechanism to fund the operation and maintenance of street lighting services and maintenance of public landscaping. After a landowner approves annexation of their property into the District and the City Council approves the annexation, the City is authorized to levy a special tax onto the annual property tax bill(s). Residential Tract 31618 (southwest corner of Moreno Beach Dr. and Bay Ave.) formed the original boundaries of the District. Since formation of the District, 30 additional landowners have authorized annexation of their property into the District.

The Rate and Method of Apportionment of Special Tax (“RMA”) for the District describes the different special tax rate areas, services provided, and the formula to calculate the special tax rate for each of the tax rate areas. Several special tax rate layers were created to accommodate a variety of scenarios to ensure costs are fairly shared between property owners. For example, there is a tax rate layer for “single-family residential street lighting” and one for “street lighting for property other than single-family residential” (e.g., commercial, industrial, or multi-family projects). Different tax rate layers are needed for street lighting because the spacing and size/type of lights differ based on the type of development. Likewise, there are several tax rate areas for maintenance of public landscaping. A property owner’s proportionate share of landscape maintenance costs will vary depending upon the total square footage of landscaping to be maintained for that development and the number of properties sharing in the cost.

### *Annexation to the District*

On February 10, 2015, the City Council adopted Ordinance No. 889, which designated the entire territory of the City as a future annexation area for the District. With the future annexation area designated, annexations can occur without an additional public hearing as long as the annexing landowner provides unanimous consent. Once annexed, parcels are subject to the annual special tax to fund the service(s) they are receiving.

The Property Owner is approved to construct a 340,178 square foot industrial warehouse/logistics building on the southwest corner of Perris Blvd. and Nandina Ave. As a condition of approval of their project(s), the Property Owner is required to provide an ongoing funding source for maintenance services of street lights and landscaping installed on public streets as part of the development project. Information for the

parcel(s) under development (or the “Subject Property”) is shown in the table below:

| Property Owner/Project   | Assessor’s Parcel Number(s)                  | Location   | Amendment No. |
|--|--|--|---------------|
| Duke Realty LTD Partnership<br>Nandina Facility<br>PEN17-0001/SCP18-0013 | 316-210-036, 316-210-037,<br>and 316-210-038 | Southwest corner of Perris<br>Blvd. and Nandina Ave. | 31            |

A property owner has two options to satisfy the condition of approval:

1. Submit a Landowner Petition unanimously approving annexation of their property into the District. Approval of the petition and special tax rate allows the City to annually levy the special tax on the property tax bill(s) of their property. This option is only available if there are fewer than 12 registered voters living within the proposed annexation area; or
2. Establish a homeowner or property owner association to provide the ongoing maintenance and operation of the improvements.

The Property Owner elected to annex the Subject Property into CFD No. 2014-01 and have the special tax applied to the annual property tax bill(s). The Office of the Riverside County Registrar of Voters confirmed there were no registered voters residing at the Subject Property allowing for the special election of the landowner to be conducted. The City Clerk received and reviewed the Landowner Petition(s) and confirmed the Property Owner unanimously approved the annexation of the Subject Property into the District (Attachment 3). Adoption of the attached resolution (Attachment 1) adds the Subject Property to the tax rate area(s) identified in the table in the Fiscal Impact section of this report and directs the recordation of the boundary map(s) (Attachment 2) and amended notice of special tax lien for Amendment No. 31.

Successful completion of the annexation process satisfies the project’s condition of approval to provide a funding source for the operation and maintenance of street lighting and landscaping on public streets.

### **ALTERNATIVES**

1. Adopt the proposed resolution(s). *Staff recommends this alternative as it will annex the Subject Property into CFD No. 2014-01 at the request of the Property Owner and satisfy the condition of approval for the proposed development(s).*
2. Do not adopt the proposed resolution(s). *Staff does not recommend this alternative as it is contrary to the request of the Property Owner, will not satisfy the condition of approval, and may delay development of the project(s).*
3. Do not adopt the proposed resolution(s) but rather continue the item to a future regularly scheduled City Council meeting. *Staff does not*

*recommend this alternative as it will delay the Property Owner from satisfying the condition of approval and may delay development of the project(s).*

## **FISCAL IMPACT**

Revenue received from the special tax is restricted and can only be used to fund the services for each tax rate area within the District. If the projected revenue received from the maximum special tax exceeds what is necessary to fund the services within each tax rate area, a lower amount will be applied to the property tax bills for all properties within the affected tax rate area. The special tax can only be applied to a property tax bill of a parcel wherein the qualified electors (i.e., landowners or registered voters, depending upon the number of registered voters) have previously provided approval. The estimated maximum special tax revenue which can be generated from this project(s) is detailed below:

| Property Owner              | Service Tax Rate Area  | Front Linear Footage adjacent to improvements <sup>1</sup> | FY 2018/19 Maximum Special Tax Rate per Front Linear Foot <sup>2</sup> | FY 2018/19 Maximum Special Tax |
|-----------------------------|--|--|--|--------------------------------|
| Duke Realty LTD Partnership | Street Lighting for Property Other than Single-Family Residential, SL-02 | 1,589  | \$3.93   | \$6,244.77                     |
| Duke Realty LTD Partnership | Landscaping for Property Other than Single-Family Residential, LM-02A    | 640  | \$13.28  | \$8,491.76                     |

<sup>1</sup>Estimated based on proposed parcel configuration. The special tax calculation will be based on final development of the project. Street lights are located on Perris Blvd. and Nandina Ave. Public landscaping is located in the Perris Blvd. median.

<sup>2</sup>The special tax applied to the property tax bill will be based on the needs of the District; it can be lower than but cannot exceed the maximum special tax. The FY 2018/19 applied rate is \$1.24 per front linear foot for SL-02 and \$7.40 per front linear foot for LM-02A.

The maximum special tax rates are subject to an annual inflation adjustment based on the change in the Consumer Price Index (CPI) or five percent (5%), whichever is greater. Each year, the City Council must authorize any proposed adjustment prior to the levy of the special tax onto the property tax bills. The increase to the maximum special tax rate cannot exceed the annual inflationary adjustment without a two-thirds approval of the qualified electors within the affected tax rate area.

## **NOTIFICATION**

Annexation materials were mailed to the Property Owner on November 29, 2018. A cover letter, Landowner Petition, RMA, and an envelope to return the completed petition were included.

## **PREPARATION OF STAFF REPORT**

Prepared by:  
Isa Rojas  
Management Analyst

Department Head Approval:  
Michael L. Wolfe, P.E.  
Public Works Director/City Engineer

Concurred by:  
Candace E. Cassel  
Special Districts Division Manager

**CITY COUNCIL GOALS**

**Revenue Diversification and Preservation.** Develop a variety of City revenue sources and policies to create a stable revenue base and fiscal policies to support essential City services, regardless of economic climate.

**Community Image, Neighborhood Pride and Cleanliness.** Promote a sense of community pride and foster an excellent image about our City by developing and executing programs which will result in quality development, enhanced neighborhood preservation efforts, including home rehabilitation and neighborhood restoration.

**CITY COUNCIL STRATEGIC PRIORITIES**

- 1. Economic Development
- 2. Public Safety
- 3. Library
- 4. Infrastructure
- 5. Beautification, Community Engagement, and Quality of Life
- 6. Youth Programs

Objective 4.2: Develop and maintain a comprehensive Infrastructure Plan to invest in and deliver City infrastructure.

**ATTACHMENTS**

- 1. Resolution Ordering Annexation - Amendment No. 31
- 2. Boundary Map CFD 2014-01 - Amendment No. 31
- 3. Certificate of Election Official - Amendment No. 31

**APPROVALS**

|                         |                   |                 |
|-------------------------|-------------------|-----------------|
| Budget Officer Approval | <u>✓ Approved</u> | 1/07/19 9:59 AM |
| City Attorney Approval  | <u>✓ Approved</u> | 1/07/19 2:05 PM |
| City Manager Approval   | <u>✓ Approved</u> | 1/08/19 3:32 PM |

## RESOLUTION NO. 2019-\_\_\_

A RESOLUTION OF THE CITY COUNCIL OF THE CITY OF MORENO VALLEY, CALIFORNIA, ORDERING THE ANNEXATION OF TERRITORY TO CITY OF MORENO VALLEY COMMUNITY FACILITIES DISTRICT NO. 2014-01 (MAINTENANCE SERVICES) AND APPROVING THE AMENDED MAP FOR SAID DISTRICT

WHEREAS, by its Resolution No. 2014-25, the City Council established the City of Moreno Valley Community Facilities District No. 2014-01 (Maintenance Services) (the "CFD") pursuant to the Mello-Roos Community Facilities Act of 1982 (Government Code Section 53311 *et seq.*) (the "Act"); and

WHEREAS, by its Ordinance No. 874, the City Council authorized an annual special tax to be levied against all non-exempt parcels of real property within the CFD (the "Special Tax") to fund street lighting services and landscape maintenance services; and

WHEREAS, in order to permit landowners to efficiently annex developing parcels to the CFD, the City Council, by its Ordinance No. 889 designated the entire territory of the City as a future annexation area for the CFD and approved the second amended and restated rate and method of apportionment for the Special Tax; and

WHEREAS, the landowner of the parcel(s) listed on Exhibit A to this Resolution, which is attached hereto and incorporated herein by reference, has submitted to the City a petition requesting and approving annexation of the listed parcel(s) (the "Annexation Parcel(s)") to the CFD; and

WHEREAS, the Annexation Parcel(s) are comprised of the territory shown on the boundary map (the "Boundary Map") "Amendment No. 31 to Boundaries of City of Moreno Valley Community Facilities District No. 2014-01 (Maintenance Services), City of Moreno Valley, County of Riverside, State of California" which is included as Exhibit B to this Resolution, and incorporated herein by this reference; and

WHEREAS, the City Council desires to annex the Annexation Parcel(s) to the CFD.

NOW, THEREFORE, THE CITY COUNCIL OF THE CITY OF MORENO VALLEY, CALIFORNIA, DOES HEREBY RESOLVE AS FOLLOWS:

1. Recitals. The above recitals are all true and correct and are herein incorporated.

2. Annexation Approved. The Annexation Parcel(s) are hereby added to and part of the CFD with full legal effect. The Annexation Parcel(s) are subject to the

1

Resolution No. 2019-\_\_\_  
Date Adopted: October 16, 2018



Special Tax associated with the Tax Rate Area(s) indicated on Exhibit A to this Resolution.

3. Description of Services. The following is a general description of all services (the "Services") provided in the CFD:

A. Landscape Maintenance Services: Maintaining, servicing, and operating landscape improvements and associated appurtenances located within the public right-of-way and within dedicated landscape easements for the CFD. These improvements may include but are not limited to parkways, medians, open space landscaping, fencing, monuments, ornamental lighting, drainage, turf, ground cover, shrubs, vines and trees, irrigation systems, and appurtenant facilities and structures. Fundable costs may include, but are not limited to: (i) contracting costs for landscape maintenance services, including litter removal, (ii) salaries and benefits of City staff, (iii) expenses related to equipment, apparatus, and supplies related to these services, (iv) City administrative and overhead costs associated with providing such services within the CFD, and (v) lifecycle costs associated with the repair and replacement of facilities.

B. Street Lighting Services: Maintaining, servicing, and operating street lights and appurtenant improvements. Fundable costs may include, but are not limited to: (i) contracting costs for street light maintenance, (ii) salaries and benefits of City staff, if the City directly provides street light maintenance services, (iii) utility expenses and the expense related to equipment, apparatus, and supplies related to these services and authorized by the Act, (iv) City administrative and overhead costs associated with providing such services for the CFD, and (v) lifecycle costs associated with the repair and replacement of facilities.

The Annexation Parcel(s) will only be provided with the services indicated on Exhibit A.

4. Amended Boundary Map. The Boundary Map attached hereto as Exhibit B is hereby approved. This map amends, and does not supersede, the existing maps of the CFD. The City Council directs that said map be filed with the Riverside County Recorder pursuant to Section 3113 of the Streets and Highways Code.

5. Notice of Special Tax Lien. The City Council directs that an amended notice of special tax lien be recorded pursuant to Section 3117.5 of the Streets and Highways Code with respect to the Annexation Parcel(s) associated with the Boundary Map.

6. This Resolution shall be effective immediately upon adoption.

7. The City Clerk shall certify to the adoption of this Resolution, and shall maintain on file as a public record this Resolution.

8. Severability. That the City Council declares that, should any provision,

2  
Resolution No. 2019-\_\_\_\_  
Date Adopted: January 15, 2019

section, paragraph, sentence or word of this Resolution be rendered or declared invalid by any final court action in a court of competent jurisdiction or by reason of any preemptive legislation, the remaining provisions, sections, paragraphs, sentences or words of this Resolution as hereby adopted shall remain in full force and effect.

9. Repeal of Conflicting Provisions. That all the provisions heretofore adopted by the City Council that are in conflict with the provisions of this Resolution are hereby repealed.

APPROVED AND ADOPTED this 15<sup>th</sup> day of January, 2019.

\_\_\_\_\_  
Mayor of the City of Moreno Valley

ATTEST:

\_\_\_\_\_  
City Clerk

APPROVED AS TO FORM:

\_\_\_\_\_  
City Attorney

Resolution No. 2019-  3    
Date Adopted: January 15, 2019

Attachment: Resolution Ordering Annexation - Amendment No. 31 (3329 : PURSUANT TO A LANDOWNER PETITION, ANNEX 3 PARCELS INTO

**RESOLUTION JURAT**

STATE OF CALIFORNIA            )  
COUNTY OF RIVERSIDE        ) ss.  
CITY OF MORENO VALLEY        )

I, Pat Jacquez-Nares, City Clerk of the City of Moreno Valley, California, do hereby certify that Resolution No. 2019-\_\_\_ was duly and regularly adopted by the City Council of the City of Moreno Valley at a regular meeting thereof held on the 15<sup>th</sup> day of January, 2019 by the following vote:

AYES:

NOES:

ABSENT:

ABSTAIN:

(Council Members, Mayor Pro Tem and Mayor)

\_\_\_\_\_  
CITY CLERK

(SEAL)

Resolution No. 2019-\_\_\_  
Date Adopted: January 15, 2019

EXHIBIT A

| List of Annexation Parcel(s)  |                           |   |                                      |
|---|---------------------------|---|--------------------------------------|
| Boundary Map Amendment No.  | Assessor's Parcel Numbers | Services  | Tax Rate Area & Maintenance Category |
| Amendment No. 31  | 316-210-036               | Street Lighting for Property Other than Single-Family Residential | SL-02                                |
|   | 316-210-037               |   |                                      |
|   | 316-210-038               | Landscaping for Property Other than Single-Family Residential     | LM-02A                               |
| <p>Based on current development plans, it is anticipated that the Annexation Group will be in the Maintenance Category listed above; however all taxes will be calculated as set forth in the Rate and Method of Apportionment.</p> <p>The parcels associated with a given development constitute a separate Annexation Group for purpose of calculating the applicable Maintenance Category (where applicable) for each Tax Rate Area. The anticipated Maintenance Category (where applicable) is shown in parenthesis following the Tax Rate Area. All capitalized terms in this paragraph have the meanings set forth in the Rate and Method of Apportionment.</p> |                           |   |                                      |

Attachment: Resolution Ordering Annexation - Amendment No. 31 (3329 : PURSUANT TO A LANDOWNER PETITION, ANNEX 3 PARCELS INTO

5  
Resolution No. 2019-\_\_\_\_  
Date Adopted: January 15, 2019

EXHIBIT B

AMENDMENT NO. 31 TO BOUNDARIES OF CITY OF MORENO VALLEY COMMUNITY FACILITIES DISTRICT NO. 2014-01 (MAINTENANCE SERVICES)

SHEET 1 OF 1

CITY OF MORENO VALLEY COUNTY OF RIVERSIDE STATE OF CALIFORNIA

(THIS MAP AMENDS, BY ADDING THE ADDITIONAL TERRITORY SHOWN HEREON, THE BOUNDARY MAP FOR CITY OF MORENO VALLEY COMMUNITY FACILITIES DISTRICT NO. 2014-01 (MAINTENANCE SERVICES), CITY OF MORENO VALLEY, RIVERSIDE COUNTY, STATE OF CALIFORNIA, PRIOR RECORDED AT BOOK 76 OF MAPS OF ASSESSMENT AND COMMUNITY FACILITIES DISTRICTS AT PAGE 69, IN THE OFFICE OF THE COUNTY RECORDER FOR THE COUNTY OF RIVERSIDE, STATE OF CALIFORNIA.)

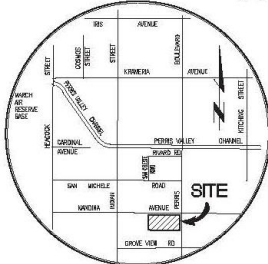

VICINITY MAP NOT TO SCALE

Table with 2 columns: MAP REFERENCE NUMBER and ASSESSOR'S PARCEL NUMBER. It lists three parcels: 1 (316-210-036), 2 (316-210-037), and 3 (316-210-038).

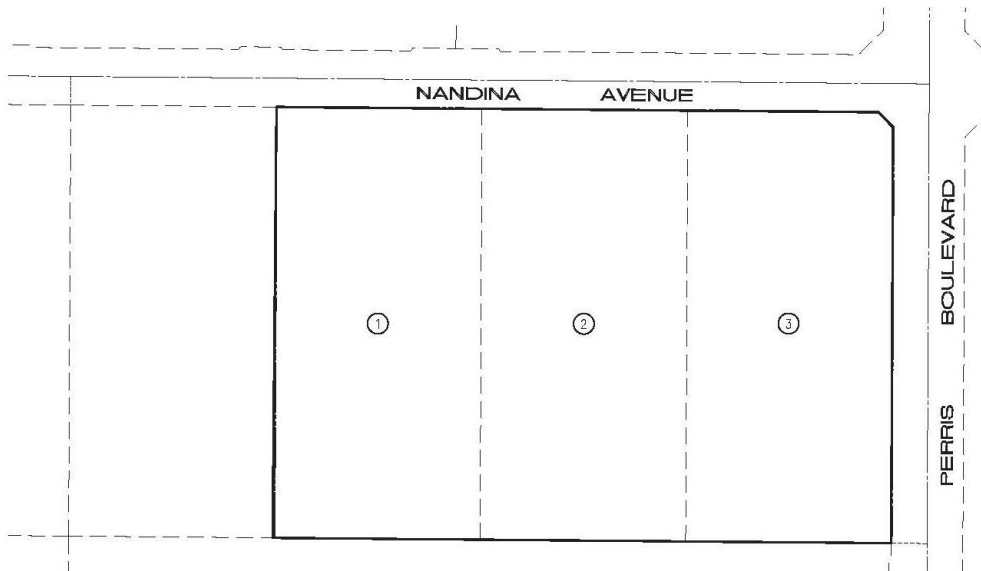

FILED IN THE OFFICE OF THE CITY CLERK THIS ... DAY OF ... 201...

CITY CLERK CITY OF MORENO VALLEY

I HEREBY CERTIFY THAT THE WITHIN MAP SHOWING AMENDED BOUNDARIES OF CITY OF MORENO VALLEY COMMUNITY FACILITIES DISTRICT NO. 2014-01 (MAINTENANCE SERVICES), CITY OF MORENO VALLEY, COUNTY OF RIVERSIDE, STATE OF CALIFORNIA, WAS APPROVED BY THE CITY COUNCIL OF THE CITY OF MORENO VALLEY AT A REGULAR MEETING THEREOF, HELD ON THE ... DAY OF ... 201..., BY ITS RESOLUTION NO. ...

CITY CLERK CITY OF MORENO VALLEY

FILED THIS ... DAY OF ... 201... AT THE HOUR OF ... O'CLOCK ... M. IN THE BOOK ... PAGE(S) ... OF MAPS OF ASSESSMENTS AND COMMUNITY FACILITIES DISTRICTS AND INSTRUMENT NO. ... IN THE OFFICE OF THE COUNTY RECORDER IN THE COUNTY OF RIVERSIDE, STATE OF CALIFORNIA.

COUNTY RECORDER COUNTY OF RIVERSIDE STATE OF CALIFORNIA

REFERENCE IS MADE TO THAT BOUNDARY MAP OF THE COMMUNITY FACILITIES DISTRICT NO. 2014-01 (MAINTENANCE SERVICES) OF THE CITY OF MORENO VALLEY RECORDED WITH THE RIVERSIDE COUNTY RECORDER'S OFFICE ON FEBRUARY 20, 2014 IN BOOK 76 OF MAPS OF ASSESSMENT AND COMMUNITY FACILITIES DISTRICTS, PAGE 69 AS INSTRUMENT NO. 2014-0086114.

REFERENCE IS FURTHER MADE TO ANNEXATION MAP NO. 2 OF COMMUNITY FACILITIES DISTRICT NO. 2014-01 (MAINTENANCE SERVICES) OF CITY OF MORENO VALLEY, COUNTY OF RIVERSIDE, CALIFORNIA (TERRITORY PROPOSED FOR ANNEXATION IN THE FUTURE, WITH THE CONDITION THAT PARCELS WITHIN THAT TERRITORY MAY BE ANNEXED ONLY WITH THE UNANIMOUS APPROVAL OF THE OWNER OR OWNERS OF EACH PARCEL OR PARCELS AT THE TIME THAT PARCEL OR THOSE PARCELS ARE ANNEXED) RECORDED WITH THE RIVERSIDE COUNTY RECORDER'S OFFICE ON DECEMBER 17, 2014 IN BOOK 77, PAGE 78 OF MAPS OF ASSESSMENT AND COMMUNITY FACILITIES DISTRICTS AS INSTRUMENT NO. 2014-0481134, WHICH DESIGNATED THE TERRITORY SHOWN HEREIN AS TERRITORY FOR FUTURE ANNEXATION TO THE COMMUNITY FACILITIES DISTRICT REFERENCED THEREON.

THE LINES AND DIMENSIONS OF EACH LOT OR PARCEL SHOWN ON THIS DIAGRAM SHALL BE THOSE LINES AND DIMENSIONS AS SHOWN ON THE RIVERSIDE COUNTY ASSESSOR'S MAPS FOR THOSE PARCELS LISTED.

THE RIVERSIDE COUNTY ASSESSOR'S MAPS SHALL GOVERN FOR ALL DETAILS CONCERNING THE LINES AND DIMENSIONS OF SUCH LOTS OR PARCELS.

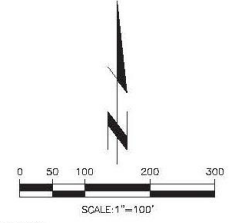

LEGEND

- Map reference number (circle with number)
Additional area to CFD 2014-01 (dashed line)

PREPARED BY: Thienes Engineering, Inc. CIVIL ENGINEERING & LAND SURVEYING 14349 FIRESTONE BOULEVARD LA MIRADA, CALIFORNIA 90638 PH: (714) 921-4811 FAX: (714) 921-4173

Attachment: Resolution Ordering Annexation - Amendment No. 31 (3329 : PURSUANT TO A LANDOWNER PETITION, ANNEX 3 PARCELS INTO

# AMENDMENT NO. 31 TO BOUNDARIES OF CITY OF MORENO VALLEY COMMUNITY FACILITIES DISTRICT NO. 2014-01 (MAINTENANCE SERVICES)

CITY OF MORENO VALLEY  
COUNTY OF RIVERSIDE  
STATE OF CALIFORNIA

(THIS MAP AMENDS, BY ADDING THE ADDITIONAL TERRITORY SHOWN HEREON, THE BOUNDARY MAP FOR CITY OF MORENO VALLEY COMMUNITY FACILITIES DISTRICT NO. 2014-01 (MAINTENANCE SERVICES), CITY OF MORENO VALLEY, RIVERSIDE COUNTY, STATE OF CALIFORNIA, PRIOR RECORDED AT BOOK 76 OF MAPS OF ASSESSMENT AND COMMUNITY FACILITIES DISTRICTS AT PAGE 69, IN THE OFFICE OF THE COUNTY RECORDER FOR THE COUNTY OF RIVERSIDE, STATE OF CALIFORNIA.)

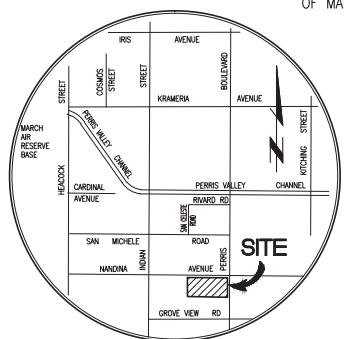

VICINITY MAP  
NOT TO SCALE

| MAP REFERENCE NUMBER | ASSESSOR'S PARCEL NUMBER |
|----------------------|--------------------------|
| ①                    | 316-210-036              |
| ②                    | 316-210-037              |
| ③                    | 316-210-038              |

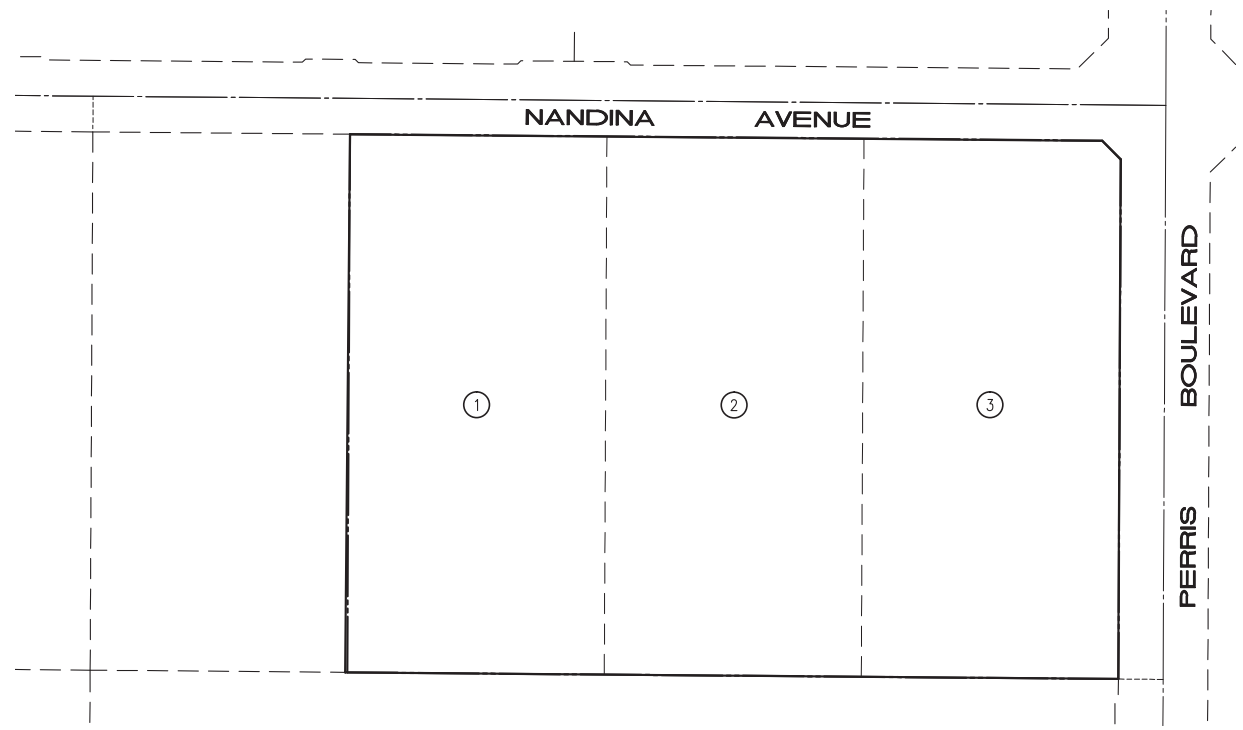

FILED IN THE OFFICE OF THE CITY CLERK THIS \_\_\_\_\_ DAY OF \_\_\_\_\_, 201\_\_.

CITY CLERK  
CITY OF MORENO VALLEY

I HEREBY CERTIFY THAT THE WITHIN MAP SHOWING AMENDED BOUNDARIES OF CITY OF MORENO VALLEY COMMUNITY FACILITIES DISTRICT NO. 2014-01 (MAINTENANCE SERVICES), CITY OF MORENO VALLEY, COUNTY OF RIVERSIDE, STATE OF CALIFORNIA, WAS APPROVED BY THE CITY COUNCIL OF THE CITY OF MORENO VALLEY AT A REGULAR MEETING THEREOF, HELD ON THE \_\_\_\_\_ DAY OF \_\_\_\_\_, 201\_\_ BY ITS RESOLUTION NO. \_\_\_\_\_

CITY CLERK  
CITY OF MORENO VALLEY

FILED THIS \_\_\_\_\_ DAY OF \_\_\_\_\_, 201\_\_ AT THE HOUR OF \_\_\_\_\_ O'CLOCK \_\_\_\_\_ M. IN THE BOOK \_\_\_\_\_ PAGE(S) \_\_\_\_\_ OF MAPS OF ASSESSMENTS AND COMMUNITY FACILITIES DISTRICTS AND INSTRUMENT NO. \_\_\_\_\_ IN THE OFFICE OF THE COUNTY RECORDER IN THE COUNTY OF RIVERSIDE, STATE OF CALIFORNIA.

COUNTY RECORDER  
COUNTY OF RIVERSIDE  
STATE OF CALIFORNIA

REFERENCE IS MADE TO THAT BOUNDARY MAP OF THE COMMUNITY FACILITIES DISTRICT NO. 2014-01 (MAINTENANCE SERVICES) OF THE CITY OF MORENO VALLEY RECORDED WITH THE RIVERSIDE COUNTY RECORDER'S OFFICE ON FEBRUARY 20, 2014 IN BOOK 76 OF MAPS OF ASSESSMENT AND COMMUNITY FACILITIES DISTRICTS, PAGE 69 AS INSTRUMENT NO. 2014-0066114.

REFERENCE IS FURTHER MADE TO ANNEXATION MAP NO. 2 OF COMMUNITY FACILITIES DISTRICT NO. 2014-01 (MAINTENANCE SERVICES) OF CITY OF MORENO VALLEY, COUNTY OF RIVERSIDE, CALIFORNIA (TERRITORY PROPOSED FOR ANNEXATION IN THE FUTURE, WITH THE CONDITION THAT PARCELS WITHIN THAT TERRITORY MAY BE ANNEXED ONLY WITH THE UNANIMOUS APPROVAL OF THE OWNER OR OWNERS OF EACH PARCEL OR PARCELS AT THE TIME THAT PARCEL OR THOSE PARCELS ARE ANNEXED) RECORDED WITH THE RIVERSIDE COUNTY RECORDER'S OFFICE ON DECEMBER 17, 2014 IN BOOK 77, PAGE 78 OF MAPS OF ASSESSMENT AND COMMUNITY FACILITIES DISTRICTS AS INSTRUMENT NO 2014-0481134, WHICH DESIGNATED THE TERRITORY SHOWN HEREIN AS TERRITORY FOR FUTURE ANNEXATION TO THE COMMUNITY FACILITIES DISTRICT REFERENCED THEREON.

THE LINES AND DIMENSIONS OF EACH LOT OR PARCEL SHOWN ON THIS DIAGRAM SHALL BE THOSE LINES AND DIMENSIONS AS SHOWN ON THE RIVERSIDE COUNTY ASSESSOR'S MAPS FOR THOSE PARCELS LISTED.

THE RIVERSIDE COUNTY ASSESSOR'S MAPS SHALL GOVERN FOR ALL DETAILS CONCERNING THE LINES AND DIMENSIONS OF SUCH LOTS OR PARCELS.

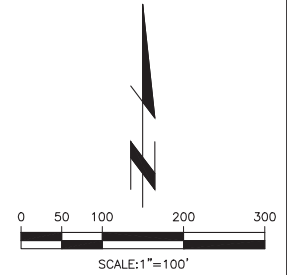

LEGEND

- ① MAP REFERENCE NUMBER
- ADDITIONAL AREA TO CFD 2014-01

PREPARED BY:  
**TEI** Thienes Engineering, Inc.  
CIVIL ENGINEERING • LAND SURVEYING  
14349 FIRESTONE BOULEVARD  
LA MIRADA, CALIFORNIA 90638  
PH.(714)521-4811 FAX(714)521-4173

**CERTIFICATE OF ELECTION OFFICIAL  
AND CONFIRMATION OF LANDOWNER PETITION**

STATE OF CALIFORNIA            )  
COUNTY OF RIVERSIDE        ) ss.  
CITY OF MORENO VALLEY        )

The undersigned, Election Official of the City of Moreno Valley, County of Riverside, State of California, Does Hereby Certify that on December 12<sup>th</sup>, I did verify the completeness of the Landowner Petition for the annexation of property into

CITY OF MORENO VALLEY COMMUNITY FACILITIES DISTRICT NO. 2014-01  
(MAINTENANCE SERVICES) – AMENDMENT NO. 31

WITNESS my hand this 12<sup>th</sup> day of December, 2018.

*for* Regina Flores  
ELECTION OFFICIAL  
CITY OF MORENO VALLEY  
STATE OF CALIFORNIA

Attachment: Certificate of Election Official - Amendment No. 31 (3329 : PURSUANT TO A LANDOWNER PETITION, ANNEX 3 PARCELS INTO



## Report to City Council

---

**TO:** Mayor and City Council  
 Mayor and City Council Acting in its Capacity as  
 President and Members of the Board of Directors of the  
 Moreno Valley Community Services District (CSD)

**FROM:** Patti Solano, Parks & Community Services Director

**AGENDA DATE:** January 15, 2019

**TITLE:** APPROVE AND EXECUTE AGREEMENT WITH MICON  
 CONSTRUCTION FOR THE CONSTRUCTION OF A  
 SKATE PARK AT MORENO VALLEY COMMUNITY PARK

---

### **RECOMMENDED ACTION**

#### **Recommendations:**

1. Approve the Agreement for the Construction of a Skate Park at Moreno Valley Community Park with Micon Construction.
2. Authorize the Executive Director to execute the Agreement for the Construction of a Skate Park at Moreno Valley Community Park with Micon Construction; and issuance of the Purchase Order for construction once the Agreement has been fully executed.
3. Authorize the Executive Director to execute any subsequent related Extensions or Amendments to the Agreement within the authorized funding, subject to the approval of the City Attorney.
4. Authorize the Parks and Community Services Director to accept the improvements into the Moreno Valley Community Services District's maintained system upon acceptance of the improvements as complete.

### **SUMMARY**

This report recommends approval of the Agreement for the Construction of a Skate Park at Moreno Valley Community Park to Micon Construction. Funding for this project is currently available through development impact fees.



## **DISCUSSION**

Moreno Valley Community Park is one of the City's oldest and largest parks utilized for a variety of special events, with the primary use being soccer. However, with the growing popularity of skateboarding, Moreno Valley residents have demonstrated a desire for a skate park located in a densely populated area of the City that is a favorite with residents. Validating the popularity of skating, resident youths and young adults filed a petition with the City urging construction of a skate park. The Mayor, Mayor Pro Tem and City staff met with a focus group of skaters to discuss the need for the new facility, potential locations, and the type of amenities preferred. Community Park was widely supported as the location for the skate park because it is highly utilized, lies adjacent to a high school, and contains existing park amenities such as restrooms, parking and a shade structure. A new skate park at this location will be constructed on an underutilized passive landscaped area, while maximizing public benefit from the other improvements currently at the park. The skate park will provide a dynamic venue to keep youth active and engaged after school hours and will serve the large and growing community of skaters of all ages. Funding for the skate park was approved by City Council at the regular meeting on August 21, 2018.

The skate park was designed by RHA Landscape Architects with assistance from the prospective users, resulting in a street skating venue including rail, stair and ramp elements. In order to reduce the construction period of a custom project, prefabricated concrete structures will be utilized. The main slab around the skate park amenities will be made of concrete fabricated on-site.

The Moreno Valley Community Park Skate Park was bid through Planet Bids and closed on December 17, 2018. There were six bids submitted on this project. The low bidder is Micon Construction, for the base bid (STL Landscape bid of \$20,018.00 was deemed non-responsive). The base bid provides all the components necessary for this project and is accommodated within the available budget. There were no alternate items in this bid. The Department recommends that the base bid be awarded to Micon Construction. The total contract will be \$596,523 which reflects a \$50,000 project contingency.

### **MVCP SKATE PARK BID RESULTS**

| <b>BID AMOUNT</b>    | <b>BIDDER</b>                             | <b>RESPONSIVE</b> |
|----------------------|---|-------------------|
| <b>\$ 546,523.00</b> | <b>Micon Construction, Inc.</b>           | <b>YES</b>        |
| \$ 574,000.00        | Horizons Construction Company Int'l, Inc. | YES               |
| \$ 574,763.50        | Three Peaks Corp                          | YES               |
| \$ 587,650.00        | Wright Construction Engineering Corp      | YES               |
| \$ 618,298.20        | IVL Contractors, Inc.                     | YES               |
| \$ 20,018.00         | STL Landscape, Inc.                       | NO                |

**ALTERNATIVES**

1. Approve and authorize the recommended actions as presented in this staff report. This alternative will allow for timely construction of the skate park. Staff recommends this alternative.
2. Elect not to approve and authorize the recommended actions as presented in this staff report, and provide further direction to staff. Staff does not recommend this alternative.

**FISCAL IMPACT**

There is no direct impact to the General Fund.

Funding is available in the following approved CIP project: \$600,000 from GL Account 3015-50-57-80007-720134, Project No. 807 0048-3015-04 Community Park (Skate Park Addition).

**PROJECT SCHEDULE**

Notice to Proceed .....January 16, 2019  
 Start of Construction .....January 29, 2019  
 Completion of Construction .....May 30, 2019

**NOTIFICATION**

Posting of the agenda in accordance with the Brown Act.

**PREPARATION OF STAFF REPORT**

Prepared By:  
Tony Hetherman  
Parks Projects Coordinator

Department Head Approval:  
Patti Solano  
Parks & Community Services Director

**CITY COUNCIL GOALS**

**Public Facilities and Capital Projects.** Ensure that needed public facilities, roadway improvements, and other infrastructure improvements are constructed and maintained.

**Positive Environment.** Create a positive environment for the development of Moreno Valley's future.

**Community Image, Neighborhood Pride and Cleanliness.** Promote a sense of community pride and foster an excellent image about our City by developing and executing programs which will result in quality development, enhanced neighborhood preservation efforts, including home rehabilitation and neighborhood restoration.

**CITY COUNCIL STRATEGIC PRIORITIES**

- 1. Economic Development
- 2. Public Safety
- 3. Library
- 4. Infrastructure
- 5. Beautification, Community Engagement, and Quality of Life
- 6. Youth Programs

Objective 5.2: Promote the installation and maintenance of cost effective, low maintenance landscape, hardscape and other improvements which create a clean, inviting community.

Objective 5.5: Promote a healthy community and lifestyle.

Objective 6.2: Improve health, wellness and fitness for Moreno Valley youth through recreation and sports programs.

**ATTACHMENTS**

- 1. Micon Agreement - COMMUNITY PARK SKATE PARK
- 2. REQUEST FOR BID 2019-034 - MVCP SKATE PARK
- 3. SPECIAL PROVISIONS - MVCP SKATE PARK

**APPROVALS**

|                         |                   |                  |
|-------------------------|-------------------|------------------|
| Budget Officer Approval | <u>✓ Approved</u> | 1/07/19 10:13 AM |
| City Attorney Approval  | <u>✓ Approved</u> | 1/03/19 3:17 PM  |
| City Manager Approval   | <u>✓ Approved</u> | 1/08/19 3:50 PM  |

Moreno Valley Community Services District of the City of Moreno Valley

**PUBLIC WORKS AGREEMENT  
 BID # 2019-034  
 COMMUNITY PARK SKATE PARK  
 PROJECT No. 807-0048**

This Public Works Agreement (“Agreement”) is made and entered into this \_\_\_\_ day of \_\_\_\_\_, 20\_\_\_\_, by and between Moreno Valley Community Services District, a district formed pursuant to California Community Services District Law, County of Riverside, State of California, hereinafter sometimes referred to as the “Agency,” and Micon Construction Inc., a corporation, hereinafter referred to as the “Contractor,” with respect to the following:

- A. The Agency desires to retain Contractor, on an independent contractor basis, to perform construction services for Moreno Valley Community Park, located at 13380 Frederick St, Moreno Valley, CA 92553 (“Project,” as described in Section 2 of this Agreement); and
- B. The public interest, convenience, necessity and general welfare will be served by this Agreement; and
- C. This Project is subject to payment of prevailing wages per the State Labor Code; and
- D. This Agreement is made and entered into the date Agency signs this Agreement.
- E. In the event of any conflict in the provisions thereof, the terms of said Bid Documents as set forth above shall control, each over the other, in the order provided. The above items are incorporated in this Agreement as though set forth in full.
  - a. This Agreement.
  - b. Any and all Contract Change Orders issued after execution of this Agreement.
  - c. Addenda Nos. 01, inclusive, issued prior to the opening of the Bids.
  - d. The Bid Documents.
  - e. The Special Provisions which include the General Provisions, Technical Provisions, and Appendices, all of which are parts of this Agreement.
  - f. The project Plans.
  - g. The City Standard Plans.
  - h. The Standard Specifications.
  - i. Reference Specifications, all of which are essential parts of this Agreement.
  - j. The Bidder’s Proposal which includes the Bidder’s Bond and Noncollusion Affidavit.

That the City and the Contractor for the consideration hereinafter named, agree as follows:

**1. CONTRACTOR INFORMATION:**

Micon Construction Inc.  
 1616 Sierra Madre Circle  
 Placentia, CA 92870  
 Business Phone: 800-949-0203, Fax No. 714-666-1007  
 Email: kim@miconconstruction.com  
 Business License Number: 20752  
 Federal Tax I.D. Number: 33-0611193  
 Contractor License Number: 744198 CA  
 License Classification(s): A, B, C-8, C-27, C-12  
 DIR PWC Registration: 1000009060

|                          |
|--------------------------|
| For Department use only. |
| DIR ID # _____           |
| CITY CONTRACT #<br>_____ |
| P.O. # _____             |

Attachment: Micon Agreement - COMMUNITY PARK SKATE PARK [Revision 1] (3355 : APPROVE AND EXECUTE AGREEMENT WITH MICON

## 2. CONTRACTOR SERVICES, FEES, AND RELEVANT DATES:

- A. The Contractor's scope of service is described in on page 1, E e-j, referenced herein and referred as "Project".
- B. The Agency's responsibility, other than payment, is described in Exhibit A attached hereto and incorporated herein by this reference.
- C. Payment terms are provided in Exhibit B attached hereto and incorporated herein by this reference.
- D. The Contractor shall furnish all materials, tools, equipment and labor, except as otherwise provided in the Plans or Special Provisions, and will perform all the work which is necessary to complete in a good, workmanlike and substantial manner the above said project in accordance with the Bid Documents for this project, the Bid Documents which are hereby specifically referred to and by such reference made a part hereof.
- E. In the event any conflict exists between the Agreement minus the Scope of Services, on the one hand, and the Scope of Services, on the other hand, the former shall supersede.
- F. The Parties agree that the specifications, standards, and procedures set forth in the 2015 Greenbook: Standard Specifications for Public Works Construction ("Greenbook") and the 2016 California Building Standards Code ("CBSC") (together, "Public Works Authority") shall govern the completion of the Project, and to such extent the Public Works Authority is incorporated herein by this reference; provided, however, in the event any conflict exists between this Agreement and the Public Works Authority, this Agreement shall supersede unless otherwise required by law.
- G. The Agreement shall commence on the date it is signed by the Agency and shall expire two (2) years following the City's acceptance of the work, pursuant to this Agreement, or release of the Performance Bond, whichever occurs first.
- H. The Contractor's starting date shall be listed on the "Notice to Proceed." The Contractor agrees to diligently prosecute the contracted work for the Project to completion within **Ninety (90) working days** after said date in the "Notice to Proceed." The Agency acknowledges that it will not unreasonably withhold approval of the Contractor's requests for extensions of time in which to complete the work required. The Contractor shall not be responsible for performance delays caused by others or delays beyond the Contractor's reasonable control (excluding delays caused by non-performance or unjustified delay by Contractor, his/her/its employees, or subcontractors), and such delays shall extend the time for performance of the work by the Contractor.
- I. The work performed in this Agreement shall be performed Monday through Friday, 7 a.m. to 5 p.m. Agency observed holidays shall be observed by the Contractor and no work shall be performed on these dates, unless prior written permission is granted.
- J. Substantial completion of work shall be evidenced by inspection and approval by Agency staff in writing.

## 3. LIQUIDATED DAMAGES

The Contractor and Agency have agreed to liquidate damages with respect to Contractor's failure to order all materials in accordance with the Notice to Proceed with Order of Materials and/or failure to fulfill the preconstruction requirements, and/or failure to complete the Work within the Contract Time. The Parties intend for the liquidated damages set forth herein to apply to this Contract as set forth in Government Code Section 53069.85. Contractor acknowledges and agrees that the liquidated damages are intended to compensate the

Agency solely for Contractor's failure to meet the deadline for completion of the Work and will not excuse Contractor from liability from any other breach, including any failure of the Work to conform to the requirements of the Agreement.

In the event that Contractor fails to order all materials in accordance with the Notice to Proceed with Order of Materials and/or fails to fulfill the preconstruction requirements and/or fails to complete the work within Project time, Contractor agrees to pay the Agency \$1,000.00 per Calendar day that completion of the work is delayed beyond the Project time, as adjusted by Contract Change Orders. The Contractor will not be assessed liquidated damages for delays occasioned by the failure of the Agency or of the owner of a utility to provide for the removal or relocation of utility facilities.

The Contractor and Agency acknowledge and agree that the foregoing liquidated damages have been set based on an evaluation of damages that the Agency will incur in the event of late completion of the work. The Contractor and Agency acknowledge and agree that the amount of such damages are impossible to ascertain as of the date of execution hereof and have agreed to such liquidated damages to fix the Agency's damages and to avoid later disputes. It is understood and agreed by Contractor that liquidated damages payable pursuant to this Agreement are not a penalty and that such amounts are not manifestly unreasonable under the circumstances existing as of the date of execution of this Agreement.

It is further mutually agreed that the Agency will have the right to deduct liquidated damages against progress payments or retainage and that the Agency will issue a Change Order and reduce the Agreement price accordingly. In the event the remaining unpaid Agreement amount is insufficient to cover the full amount of liquidated damages, Contractor shall pay the difference to the Agency.

#### 4. LABOR LAWS AND PREVAILING WAGES

- A. All work or services performed within the State of California pursuant to this Agreement by Contractor, Contractor's employees and independent contractors, or Contractor's subcontractors and its subcontractors' employees and independent contractors shall be performed by individuals lawfully permitted to perform such work or services in the State of California and/or the United States of America pursuant to all applicable State and/or Federal labor laws, rules and regulations including, but not limited to, any State or Federal law, rule or regulation prohibiting the employment of undocumented workers or any other person not lawfully permitted to perform said work or services in the State of California or the United States of America.
- B. Contractor represents that it is an equal opportunity employer and shall not discriminate against any subcontractor, employee, or applicant ("person") for employment because of denial of family and medical care leave; race; religious creed (including religious dress and grooming practices); color; national origin (including language use restrictions); ancestry; physical disability or mental disability (including HIV and Aids); medical condition (cancer and genetic characteristics); genetic information; military or veteran status; marital status; gender, gender identity, and gender expression; sex (which includes pregnancy, childbirth, breastfeeding and medical conditions related to pregnancy, childbirth or breastfeeding); age or sexual orientation. Unless otherwise permitted under the law, Contractor shall not refuse to hire or employ any such person or refuse to select any such person for a training program leading to employment, or bar or discharge any such person from employment or from a training program leading to

- employment, or otherwise discriminate against any such person in compensation or in terms, conditions, or privileges of employment.
- C. Contractor and all of Contractor's subcontractors, if any, shall pay each employee engaged in all applicable trades or occupation not less than the prevailing hourly wage rate for work of a similar character in the locality in which the public work is performed, and not less than the general prevailing rate of per diem wages for holiday and overtime work. In accordance with the provisions of Section 1770 of the California Labor Code ("Labor Code"), the Director of Department of Industrial Relations of the State of California has determined the general prevailing rates of wages and employer payments for health and welfare, pension, vacation, travel time, and subsistence pay as provided for in Labor Code Section 1773.8, apprenticeship or other training programs authorized by Labor Code Section 3093 and similar purposes applicable to the work to be done. Said wages are available through the California Department of Industrial Relations' Internet website at <http://www.dir.ca.gov/dlsr/PWD/index.htm> and are on file at City Hall, as provided in Section 1773.2 of the Labor Code. Said rates shall be posted at the Project site where work is to be performed, in accordance with Labor Code Section 1773.2. Contractor shall access a copy of the wage rate determination and shall make all subcontractors, if any, aware of the determination. As the wage determination for each craft reflects an expiration date, it shall be the Contractor's responsibility to ensure that the prevailing wage rates of concern are current and paid. Subject to the safe harbor provisions of Labor Code Section 1775, Contractor shall forfeit to the Agency an amount not to exceed two hundred dollars (\$200) for each calendar day or portion thereof, as set by the Labor Commissioner in accordance with the terms of Labor Code section 1775, for each laborer, workmen or mechanics employed that is paid less than the general prevailing rate of wages herein referred to and stipulated for any work done under the proposed contract, by him, or by any subcontractor under him, in violation of the provisions of the Labor Code, and in particular, Sections 1770 to 1781 inclusive. Contractor and any and all or its subcontractors shall forfeit to the Agency twenty-five dollars (\$25) for each worker employed in the performance of this Agreement for each calendar day during which the worker is required or permitted to work more than eight (8) hours in any one calendar day and forty (40) hours in any one calendar week in violation of the provisions of Section 1813 of the Labor Code. In the event the total cost of the Project is thirty thousand dollars (\$30,000.00) or more, Contractor shall further comply with provisions set forth in Labor Code Section 1777.5 pertaining to employment of properly registered apprentices, including without limitation the obligation to (i) pay employed apprentices the prevailing rate of per diem wages for apprentices in the trade to which he or she is registered and shall be employed only at the work of craft or trade to which he or she is registered; (ii) employ apprentices in at least the ratio as set forth in said section; (iii) submit contract award information to an applicable apprenticeship program; and (iv) contribute to California Apprenticeship Council.
- D. Contractor and all subcontractors hired to perform any work under the Project shall keep accurate payroll records, including the name, address, social security number, work classification, straight time and overtime hours worked each day and week, and the actual per diem wages paid to each worker, in accordance with Section 1776 of the Labor Code. Payroll records shall be on forms provided by the Division of Labor Standards Enforcement ("DLSE") or in a manner containing the same information as the forms provided by the DLSE. Failure to comply with the above may result in monetary penalties to the Contractor or affected subcontractor. Payroll records shall be verified by written declaration made under penalty of perjury, that the information contained in the records is true and correct. Contractor and any and all subcontractors shall make a certified copy of all payroll records available for inspection by DLSE, the Agency or any member of the public and otherwise provide certified copies of such records to any of the

foregoing within ten (10) days of Contractor's and subcontractor's receipt of written request therefor. Failure to comply with the above may result in monetary penalties, in accordance with Labor Code Section 1776(d) and (h).

- E. Notwithstanding anything else to the contrary, Contractor hereby acknowledges that all contractors must be registered with the Department of Industrial Relations ("Department") pursuant to Labor Code Section [1725.5](#) in order to be qualified to bid on, be listed in a bid proposal, subject to the requirements of Section 4104 of the Public Contract Code, or engage in the performance of any public work contract, including this Agreement, that is subject to the payment of prevailing wages. Contractor represents and warrants that Contractor is [registered](#) with the Department in the manner prescribed by the Department and has paid the requisite application fee, as required by Labor Code Section 1725.5. Ready-mix haulers and companies that deliver ready-mixed concrete for public works projects are considered subcontractors under Labor Code section [1722.1](#) and must [register](#) with the Department of Industrial Relations as specified in Labor Code section [1725.5](#). Moreover, prior to Contractor entering into any contracts with any subcontractor, Contractor shall obtain proof that all such subcontractors have also registered with the Department in accordance with Section [1725.5](#).

## 5. STANDARD TERMS AND CONDITIONS:

- A. Control of Work. Contractor is solely responsible for the content and sequence of the work, and will not be subject to control and direction as to the details and means for accomplishing the anticipated results of services. The Agency will not provide any training to Contractor or his/her/its employees.
- B. Intent of Parties. Contractor is, and at all times shall be, an independent contractor and nothing contained herein shall be construed as making the Contractor or any individual whose compensation for services is paid by the Contractor, an agent or employee of the City and/or CSD, or authorizing the Contractor to create or assume any obligation or liability for or on behalf of the Agency, or entitling the Contractor to any right, benefit, or privilege applicable to any officer or employee of the Agency.
- C. Subcontracting. Contractor may retain or subcontract for the services of other necessary contractors with the prior written approval of the Agency. Payment for such services shall be the responsibility of the Contractor.
- D. Extra Work and Change Orders. Extra work and change orders shall become a part of this Agreement once the extra work or change order is approved in writing and signed by the Agency and Contractor, prior to the commencement of any extra work or change in work covered by the change order. The Agency's form change order shall be used for both extra work and a change in work. The change order must describe the scope of the extra work or change in work, and the cost to be added or subtracted from this Agreement. The Agency shall not require Contractor to perform any extra work or a change in work without written authorization. A change order shall not be enforceable against the Agency unless the change order complies with this provision.
- E. Conformance to Applicable Requirements. All work prepared by Contractor shall be subject to the approval of Agency.
- F. Contractor's Representative. Contractor hereby designates **Kim Garrigues**, or his or her designee, to act as its representative for the performance of this Agreement ("Contractor's Representative"). Contractor's Representative shall have full authority to represent and act on behalf of the Contractor for all purposes under this Agreement. The Contractor's Representative shall supervise and direct the services, using his or her best skill and attention, and shall be responsible for all means, methods, techniques, sequences and procedures and for the satisfactory coordination of all portions of the services under this Agreement.



- G. Substitution of Key Personnel. Contractor has represented to Agency that certain key personnel will perform and coordinate the services under this Agreement. Should one or more of such personnel become unavailable, Contractor may substitute other personnel of at least equal competence upon written approval of Agency. In the event that Agency and Contractor cannot agree as to the substitution of key personnel, Agency shall be entitled to terminate this Agreement for cause. As discussed below, any personnel who fail or refuse to perform the services in a manner acceptable to the Agency, or who are determined by the Agency to be uncooperative, incompetent, a threat to the adequate or timely completion of the Project or a threat to the safety of persons or property, shall be promptly removed from the Project by the Contractor at the request of the Agency. The key personnel for performance of this Agreement are as follows: **Kim Garrigues.**
- H. Agency's Representative. The Agency hereby designates the Director of Parks and Community Services of the City of Moreno Valley, or his or her designee, to act as its representative for the performance of this Agreement ("Agency's Representative"). Contractor shall not accept direction or orders from any person other than the Agency's Representative or his or her designee. The Agency's representatives are as follow: Tony Hetherman.
- I. Standard of Care; Performance of Employees. Contractor shall perform all services under this Agreement in a skillful and competent manner, consistent with the standards generally recognized as being employed by professionals in the same discipline in the State of California. Contractor represents and maintains that it is skilled in the profession necessary to perform the services. Contractor warrants that all employees and subcontractors shall have sufficient skill and experience to perform the services assigned to them. Finally, Contractor represents that it, its employees and subcontractors have all licenses, permits, qualifications and approvals of whatever nature that are legally required to perform the services and that such licenses and approvals shall be maintained throughout the term of this Agreement. Any employee of the Contractor or its subcontractors who is determined by the Agency to be uncooperative, incompetent, a threat to the adequate or timely completion of the Project, a threat to the safety of persons or property, or any employee who fails or refuses to perform the services in a manner acceptable to the Agency, shall be promptly removed from the Project by the Contractor and shall not be re-employed to perform any of the services or to work on the Project.
- J. Legal Considerations. The Contractor shall comply with applicable federal, state, and local laws, rules and regulations in the performance of this Agreement.
- K. Contractor Indemnification. To the fullest extent permitted by law, the Contractor assumes liability for and agrees, at the Contractor's sole cost and expense, to promptly and fully indemnify, protect, hold harmless and defend (even if the allegations are false, fraudulent, or groundless), the Moreno Valley Community Services District (sometimes "CSD"), the City of Moreno Valley (sometimes "City"), the City Council and Board of Directors and each member thereof, and the Moreno Valley Housing Authority and all of their respective officials, officers, directors, employees, commission members, representatives and agents (collectively "Indemnitees" and singularly "Indemnitee"), from and against any and all claims, allegations, actions, suits, arbitrations, administrative proceedings, regulatory proceedings, or other legal proceeds, causes of action, demands, costs, judgments, liens, stop notices, penalties, liabilities, damages, losses, anticipated losses of revenues, and expenses (including, but not limited to, any fees of accountants, attorneys, experts or other professionals, or investigation expenses), or losses of any kind or nature whatsoever, whether actual, threatened or alleged, arising out of, resulting from, or in any way (either directly or indirectly), related to the work or the Project or any breach of this Agreement by Contractor or any of its officers, agents, employees, subcontractors, sub-subcontractors, or any person performing any of the

work, pursuant to a direct or indirect contract with the Contractor (“Indemnity Claims”). Such Indemnity Claims include, but are not limited to, claims for:

1. Any activity on or use of the CSD’s and/or City’s premises or facilities;
2. Any liability incurred due to Contractor acting outside the scope of its authority pursuant to this Agreement, whether or not caused in part by an Indemnitee;
3. The failure of Contractor or the work to comply with any applicable law, permit or orders;
4. Any misrepresentation, misstatement or omission with respect to any statement made in this Agreement or any document furnished by the Contractor in connection therewith;
5. Any breach of any duty, obligation or requirement under this Agreement or any document furnished by Contractor in connection therewith, including, but not limited to any breach of Contractor’s warranties, representations or agreements;
6. Any failure to coordinate the work with Agency’s separate contractors;
7. Any failure to provide notice to any party as required by this Agreement or any document furnished in connection therewith;
8. Any failure to act in such a manner as to protect the Project from loss, cost, expense or liability;
9. Damage or injury to real property or personal property, equipment and materials (including, but without limitation, property under the care and custody of the Contractor or the City and/or CSD), and injury or death sustained by any person or persons (including, but not limited to, Contractor’s employees or agents, and members of the general public);
10. Any liability imposed by applicable law including, but not limited to criminal or civil fines or penalties;
11. Any dangerous, hazardous, unsafe or defective condition of, in or on the Project site, of any nature whatsoever, which may exist by reason of any act, omission, neglect, or any use or occupation of the site by Contractor, its officers, agents, employees, or subcontractors;
12. Any operation conducted upon or any use or occupation of the Project site by Contractor, its officers, agents, employees, or subcontractors under or pursuant to the provisions of this Agreement or otherwise;
13. Any acts, errors, omission or negligence of Contractor, its officers, agents, employees, or subcontractors;
14. Infringement of any patent rights, licenses, copyrights or intellectual property which may be brought against the Contractor or Agency arising out of Contractor’s work, for which the Contractor is responsible; and
15. Any and all claims against the Agency seeking compensation for labor performed or materials used or furnished to be used in the work or alleged to have been furnished on the Project, including all incidental or consequential damages resulting to the Agency from such claims.

- L. Indemnitees’ Active Negligence. Contractor’s obligations to indemnify and hold the Indemnitees harmless **exclude** only such portion of any Indemnity Claim which is attributable to the active negligence or willful misconduct of the Indemnitees, provided such active negligence or willful misconduct is determined by agreement of the parties or by findings of a court of competent jurisdiction. In instances where an Indemnitee’s active negligence accounts for only a percentage of the liability for the Indemnity Claim involved, the obligation of Contractor will be for that entire percentage of liability for the Indemnity Claim not attributable to the active negligence or willful misconduct of the Indemnitee(s). Such obligation shall not be construed to negate, abridge or otherwise reduce any other right or obligation of indemnity which would otherwise exist as to any party or person described in this section. Subject to the limits set forth herein, the

- Contractor, at its own expense, shall satisfy any resulting judgment that may be rendered against any Indemnitee resulting from an Indemnity Claim. The Indemnitees shall be consulted with regard to any proposed settlement.
- M. Independent Defense Obligation. The duty of the Contractor to indemnify and hold harmless the Indemnitees includes the separate and independent duty to defend the Indemnitees, which duty arises immediately upon receipt by Contractor of the tender of any Indemnity Claim from an Indemnitee. The Contractor's obligation to defend the Indemnitee(s) shall be at Contractor's sole expense, and not be excused because of the Contractor's inability to evaluate liability or because the Contractor evaluates liability and determines that the Contractor is not liable. This duty to defend shall apply whether or not an Indemnity Claim has merit or is meritless, or which involves claims or allegations that any or all of the Indemnitees were actively, passively, or concurrently negligent, or which otherwise asserts that the Indemnitees are responsible, in whole or in part, for any Indemnity Claim. The Contractor shall respond within thirty (30) calendar days to the tender of any Indemnity Claim for defense and/or indemnity by an Indemnitee, unless the Indemnitee agrees in writing to an extension of this time. The defense provided to the Indemnitees by Contractor shall be by well qualified, adequately insured and experienced legal counsel acceptable to the Agency.
- N. Intent of Parties Regarding Scope of Indemnity. It is the intent of the parties that the Contractor and its subcontractors of all tiers shall provide the Indemnitees with the broadest defense and indemnity permitted by applicable law. In the event that any of the defense, indemnity or hold harmless provisions in the Agreement are found to be ambiguous, or in conflict with one another, it is the parties' intent that the broadest and most expansive interpretation in favor of providing defense and/or indemnity to the Indemnitees be given effect.
- O. Waiver of Indemnity Rights Against Indemnitees. With respect to third party claims against the Contractor, to the fullest extent permitted by law, the Contractor waives any and all rights to any type of express or implied indemnity against the Indemnitees.
- P. Subcontractor Requirements. In addition to the requirements set forth hereinabove, Contractor shall ensure, by written subcontract agreement, that each of Contractor's subcontractors of every tier shall protect, defend, indemnify and hold harmless the Indemnitees with respect to Indemnity Claims arising out of, in connection with, or in any way related to each such subcontractors' work on the Project in the same manner in which Contractor is required to protect, defend, indemnify and hold the Indemnitees harmless. In the event Contractor fails to obtain such defense and indemnity obligations from others as required herein, Contractor agrees to be fully responsible to the Indemnitees according to the terms of this section.
- Q. No Limitation or Waiver of Rights. Contractor's obligations under this section are in addition to any other rights or remedies which the Indemnitees may have under the law or under the Agreement. Contractor's indemnification and defense obligations set forth in this section are separate and independent from the insurance provisions set forth in the Agreement, and do not limit, in any way, the applicability, scope, or obligations set forth in such insurance provisions. The purchase of insurance by the Contractor with respect to the obligations required herein shall in no event be construed as fulfillment or discharge of such obligations. In any and all claims against the Indemnitees by any employee of the Contractor; any subcontractor; any supplier of the Contractor or subcontractors; anyone directly or indirectly employed by any of them; or anyone for whose acts any of them may be liable, the obligations under this Agreement shall not be limited in any way by any limitation on the amount or type of damages, compensation or benefits payable by or for the Contractor or any subcontractor or any supplier of either of them, under workers' compensation acts, disability benefit acts or other employee benefit acts. Failure of the Agency to monitor compliance with these requirements

imposes no additional obligations on the Agency and will in no way act as a waiver of any rights hereunder.

R. Withholding to Secure Obligations. Subject to applicable law, in the event a claim arises prior to final payment to Contractor, the Agency may, in its sole discretion, reserve, retain or apply any monies due Contractor for the purpose of resolving such claims; provided, however, the Agency may release such funds if the Contractor provides the Agency with reasonable assurances of protection of the Indemnitees' interests. The Agency shall, in its sole discretion, determine whether such assurances are reasonable.

S. Survival of Indemnity Obligations. Contractor's obligations under this section are binding on Contractor's and its subcontractors' successors, heirs and assigns and shall survive the completion of the work or termination of the Contractor's performance of the work.

T. Insurance Requirements. The Contractor shall procure and maintain at its sole expense and throughout the term of this Agreement and any extension thereof, Commercial General Liability, Automobile Liability, and Workers' Compensation Insurance with such coverage limits as described herein.

U. Additional Insured Endorsements. The Contractor shall provide Agency with certificates of insurance and endorsements as evidence of the insurance coverages required herein, and shall cause such certificates of insurance and endorsements to include:

***"the City of Moreno Valley (City), the Moreno Valley Community Services District (CSD), the Moreno Valley Housing Authority, and their officers, officials, employees, agents, and volunteers are additional insureds as respects to General Liability and Auto Liability insurance. This insurance is primary, and our obligations are not affected by any other insurance carried by such additional insured whether primary, excess, contingent, or on any other basis. Waiver of subrogation for Workers' Compensation and Employer's Liability insurance as respects to the City of Moreno Valley (City), the Moreno Valley Community Services District (CSD), the Moreno Valley Housing Authority and each of their officers, officials, employees, agents, and volunteers."***

For the Commercial General Liability coverage, said parties shall be named as additional insureds utilizing either:

1. Insurance Services Office ("ISO") Additional Insured endorsement CG 20 10 (04/13); or
2. Substitute endorsements providing equivalent coverage, approved by the Agency.

The endorsements shall be signed by a person authorized by the insurer to bind coverage on its behalf. The coverage shall contain no special limitations on the scope of protection afforded to such additional insureds. Coverage for such additional insureds does not extend to liability to the extent prohibited by Insurance Code Section 11580.4.

V. Waivers of Subrogation. All policies of insurance required by the Agreement shall include or be endorsed to provide a waiver by the insurers of any rights of recovery or subrogation that the insurers may have at any time against the *"City of Moreno Valley (City), the Moreno Valley Community Services District (CSD), the Moreno Valley Housing Authority, and their officers, officials, employees, agents, and volunteers."*

W. Primary and Noncontributory Coverage. All policies and endorsements shall stipulate that the Contractor's (and the subcontractors') insurance coverage shall be primary and noncontributory insurance as respects the *"City of Moreno Valley (City), the Moreno Valley Community Services District (CSD), the Moreno Valley Housing Authority, and their officers, officials, employees, agents, and volunteers,"* and shall be excess of the Contractor's (and its subcontractors') insurance and shall not contribute with it.

For the primary and noncontributory coverage, said parties shall be named as additional insureds utilizing either:

1. Insurance Services Office ("ISO") Additional Insured endorsement CG 20 10

Attachment: Micon Agreement - COMMUNITY PARK SKATE PARK [Revision 1] (3355 : APPROVE AND EXECUTE AGREEMENT WITH MICON

(01/13); or

2. Substitute endorsements providing equivalent coverage, approved by Agency.  
X. Coverage Applies Separately to Each Insured and Additional Insured. Coverage shall state that the Contractor’s (and its subcontractors’) insurance shall apply separately to each insured or additional insured against whom claim is made or suit is brought, except with respect to the limits of the insurer’s liability. Coverage shall apply to any claim or suit brought by an additional insured against a named insured or other insured.

Y. Self-Insurance. Any self-insurance (including deductibles or self-insured retention in excess of \$50,000) in lieu of liability insurance must be declared by Contractor and approved by the Agency in writing prior to execution of the Agreement. The Agency’s approval of self-insurance, if any, is within the Agency’s sole discretion and is subject to the following conditions:

Contractor must, at all times during the term of the Agreement and for a period of at least **one (1)** year after completion of the Project maintain and upon Agency’s reasonable request provide evidence of:

1. Contractor’s “net worth” (defined as “total assets” [defined as all items of value owned by the Contractor including tangible items such as cash, land, personal property and equipment and intangible items such as copyrights and business goodwill]) minus total outside liabilities must be reflected in a financial statement for the prior fiscal year reflecting sufficient income and budget for Contractor to afford at least one loss in an amount equal to the amount of self-insurance;

2. financial statements showing that Contractor has funds set aside/budgeted to finance the self-insured fund (i.e., Contractor has a program that fulfills functions that a primary insurer would fill); and

3. a claims procedure that identifies how a claim is supposed to be tendered to reach the financing provided by the self-insured fund.

If at any time after such self-insurance has been approved Contractor fails to meet the financial thresholds or otherwise fails to comply with the provisions set forth in this section, at the option of the Agency:

a. the Contractor shall immediately obtain and thereafter maintain the third party insurance required under this section, and otherwise on the terms required above; or

b. the insurer shall reduce or eliminate such deductibles or self-insured retention as respects the “*City of Moreno Valley (City), the Moreno Valley Community Services District (CSD), the Moreno Valley Housing Authority, and their officers, officials, employees, agents, and volunteers;*” or

c. the Contractor shall procure a bond guaranteeing payment of losses and related investigation, claim administration, and defense expenses.

Z. Insurer Financial Rating. Insurance companies providing insurance hereunder shall be rated A-:VII or better in Best’s Insurance Rating Guide and shall be legally licensed and qualified to conduct insurance business in the State of California.

AA. Notices to Agency of Cancellation or Changes. Each insurance policy described in this Agreement shall contain a provision or be endorsed to state that coverage will not be cancelled without **thirty (30) days’** prior written notice by certified or registered mail to the Agency (this obligation may be satisfied in the alternative by requiring such notice to be provided by Contractor’s insurance broker and set forth on its Certificate of Insurance provided to the Agency), except that cancellation for non-payment of premium shall require (10) days prior written notice by certified or registered mail. If an insurance carrier cancels any policy or elects not to renew any policy required to be maintained by Contractor pursuant to the Agreement, Contractor agrees to give written notice to the Agency at the address indicated in this Agreement. Contractor agrees to provide the same notice of cancellation and non-renewal to the Agency that is required by such policy(ies) to be provided to the First Named Insured under such policy(ies). Contractor

Attachment: Micon Agreement - COMMUNITY PARK SKATE PARK [Revision 1] (3355 : APPROVE AND EXECUTE AGREEMENT WITH MICON

shall provide confirmation that the required policies have been renewed not less than seven (7) days prior to the expiration of existing coverages and shall deliver renewal or replacement policies, certificates and endorsements to the City Clerk within fourteen (14) days of the expiration of existing coverages. Contractor agrees that upon receipt of any notice of cancellation or alteration of the policies, Contractor shall procure within five (5) days, other policies of insurance similar in all respects to the policy or policies to be cancelled or altered. Contractor shall furnish to the City Clerk copies of any endorsements that are subsequently issued amending coverage or limits within fourteen (14) days of the amendment.

BB. Commercial General Liability.

1. Coverage shall be written on an ISO Commercial General Liability "occurrence" form CG 00 01 (10/01 or later edition), Acord Certificate of Liability form 25 (2014/01), or equivalent form approved by the Agency for coverage on an occurrence basis. The insurance shall cover liability, including, but not limited to, that arising from premises operations, stop gap liability, independent contractors, products-completed operations, personal injury, advertising injury, and liability assumed under an insured contract. The policy shall be endorsed to provide the Aggregate Per Project Endorsement ISO form CG 25 03 (11/85) or equivalent form approved by the Agency. Coverage shall contain no contractors' limitation or other endorsement limiting the scope of coverage for liability arising from pollution, explosion, collapse, or underground (x, c, u) property damage. Contractor shall provide Products/Completed Operations coverage to be maintained continuously for a minimum of **one (1) year** after acceptance of the Project, and any extension of the one-year correction guarantee period after acceptance.

2. Contractor shall maintain Commercial General Liability insurance with the following minimum limits: \$1,000,000 per occurrence / \$2,000,000 aggregate / \$2,000,000 products-completed operations.

CC. Business Automobile Liability. Coverage shall be written on ISO form CA 00 01 (12/93 or later edition) or a substitute form providing equivalent coverage for owned, hired, leased and non-owned vehicles, whether scheduled or not, with \$1,000,000 combined single limit per accident for bodily injury and property damage. Additionally, the policy shall be endorsed utilizing ISO form CA 20 48 (10/14) or equivalent form.

DD. Workers' Compensation. Contractor shall comply with the applicable sections of the California Labor Code concerning workers' compensation for injuries on the job. Compliance is accomplished in one of the following manners:

1. Provide copy of permissive self-insurance certificate approved by the State of California; or

2. Secure and maintain in force a policy of workers' compensation insurance with statutory limits and Employer's Liability Insurance with a minimal limit of **\$1,000,000** per accident; or

3. Provide a "waiver" form certifying that no employees subject to the Labor Code's Workers' Compensation provision will be used in performance of this Agreement.

EE. Subcontractors' Insurance. The Contractor shall include all subcontractors as insureds under its policies or shall furnish separate certificates and endorsements for each subcontractor. All coverages for subcontractors shall be subject to all of the requirements stated herein.

FF. Intellectual Property. Any system or documents developed, produced or provided under this Agreement, including any intellectual property discovered or developed by Contractor in the course of performing or otherwise as a result of its work, shall become the sole property of the Agency unless explicitly stated otherwise in this Agreement. The Contractor may retain copies of any and all material, including drawings, documents, and specifications, produced by the Contractor in performance of this Agreement. The Agency and the Contractor agree that to the extent permitted by law, until final approval

by the Agency all data shall be treated as confidential and will not be released to third parties without the prior written consent of both parties.

GG. Entire Agreement. This Agreement constitutes the entire agreement between the parties. There are no understandings, agreements, or representations of warranties, expressed or implied, not specified in this Agreement. This Agreement applies only to the current proposal as attached. This Agreement may be modified or amended only by a subsequent written Agreement signed by both parties. Assignment of this Agreement is prohibited without prior written consent.

HH Termination.  
1. The Agency may terminate this Agreement without cause by giving at least ten (10) days written notice to the Contractor. The written notice shall specify the date of termination. Upon receipt of such notice, the Contractor may continue work through the date of termination, provided that no work or service(s) shall be commenced or continued after receipt of the notice which is not intended to protect the interest of the Agency. The Agency shall pay the Contractor within thirty (30) days after receiving any invoice after the date of termination for all non-objected to services performed by the Contractor in accordance herewith through the date of termination.

2. Either party may terminate this Agreement for cause. In the event the Agency terminates this Agreement for cause, the Contractor shall perform no further work or service(s) under the Agreement unless the notice of termination authorizes such further work.

II. Payment.  
1. Payments to the Contractor pursuant to this Agreement will be reported to federal and state taxing authorities as required. Contractor is independently responsible for the payment of all applicable taxes. Where the payment terms provide for compensation on a time and materials basis, the Contractor shall maintain adequate records to permit inspection and audit of the Contractor's time and materials charges under the Agreement. Upon reasonable notice, such records must be made available to the Agency's agent; however, nothing herein shall convert such records into public records, unless otherwise required by law. Such records shall be retained by the Contractor for three (3) years following completion of the services under the Agreement.

2. Pursuant to Public Contract Code section 9203, the Agency shall retain no less than five percent (5%) of the compensation to be paid to Contractor which shall be released to the Contractor no later than sixty (60) days from the date of the Contractor's acceptance of the work pursuant to this Agreement.

JJ. Stop Payment Notice Withholdings. The Agency may withhold payments to cover claims filed under Civil Code § 9350 et seq.

KK. Restrictions on CSD/City Employees. The Contractor shall not employ any CSD or City employee or official in the work performed pursuant to this Agreement. No officer or employee of the CSD or City shall have any financial interest in this Agreement in violation of federal, state, or local law.

LL. Choice of Law and Venue. The laws of the State of California shall govern the rights, obligations, duties, and liabilities of the parties to this Agreement, and shall govern the interpretation of this Agreement. Any legal proceeding arising from this Agreement shall be brought in the appropriate court located in Riverside County, State of California.

MM. Legal Action.  
3. Should either party bring any legal or equitable action for the purpose of protecting or enforcing its rights under this Agreement, the prevailing party in such action shall recover in addition to all other relief, its reasonable attorney's fees and court costs, fixed by the court.

4. In addition to the foregoing award of attorney's fees, the prevailing party shall be entitled to its attorneys' fees incurred in any post judgement proceedings to enforce any

Attachment: Micon Agreement - COMMUNITY PARK SKATE PARK [Revision 1] (3355 : APPROVE AND EXECUTE AGREEMENT WITH MICON

judgments in connection with this Agreement. The provision is separate and several and shall survive the merger of this provision into any judgement.

NN. Warranty.

1. The Contractor, the Contractor’s heirs, executors, administrators, successors, and/or assigns guarantee that all work performed under this Agreement fully meets the requirements thereof as to quality of workmanship and materials furnished, including without limitation materials to be of good quality and fit for their purpose and intended use. If any defects in materials or workmanship become evident prior to expiration of the term of this Agreement or release of the Performance Bond, whichever occurs first, the Contractor shall, at his or her own expense, make any repair(s) or replacement(s) necessary to restore the work to full compliance with the plans and specifications. Contractor shall also repair, replace and restore any other work which is displaced in correcting defective work which the Agency by reason of such defects reasonably suspects may also be defective. In the event of a failure to commence with the compliance of above-mentioned requirements within seven (7) calendar days after being notified in writing of failure to diligently pursue such compliance to completion, the Agency is hereby authorized to proceed to have the defects repaired and made good at the expense of Contractor who hereby agrees to pay the cost and charges therefor immediately on demand.

2. If, in the opinion of the Agency, nonconforming work creates a dangerous condition or requires immediate correction or repair to prevent further loss to the Agency or to prevent interruption of operations, the Agency shall attempt to give the Contractor notice of the same. If Contractor cannot be contacted or does not comply with the Agency’s request for correction within a reasonable time as determined by the Agency, the Agency may proceed to make such correction or provide such repair. The costs of such correction or repair shall be charged against Contractor, who agrees to make payment for said costs upon demand. Corrective action by the Agency will not relieve Contractor or Contractor's sureties or insurers of the guarantees and indemnities of this Agreement.

3. This section does not in any way limit the Agency’s remedies available under the law, or the guarantee on any items for which a longer guarantee is specified or on any items for which a manufacturer or supplier gives a longer guarantee period. Contractor agrees to act as a co-guarantor with such manufacturer or supplier and shall furnish the Agency all appropriate guarantees or warranty certificates upon completion of the Project. No manufacturer's guarantee period shall in any way limit the liability of Contractor or Contractor's sureties and insurers under the indemnity or insurance provisions of this Agreement.

OO. Records. The Contractor agrees that he or she and its subcontractors shall maintain and keep books, payrolls, invoices of materials, and records on a current basis, and recordings of all transactions pertaining to this Agreement in a form in accordance with generally acceptable accounting principles. Said books and records shall be made available to the City, the CSD, County of Riverside, the State of California, the federal government and to any authorized representative thereof for purposes of audit and inspection at all reasonable times and places. All such books, payrolls, invoices of materials, and records shall be retained for such periods of time as required by law, provided, however, notwithstanding any shorter period of retention, all books, records, and supporting detail shall be retained for a period of at least three (3) years after acceptance of the Project by the Agency.

PP. Performance. The parties do for themselves, their heirs, executors, administrators, successors and assigns agree to the full performance of all of the provisions herein contained. The Contractor may not, either voluntarily or by action of law, assign any

Attachment: Micon Agreement - COMMUNITY PARK SKATE PARK [Revision 1] (3355 : APPROVE AND EXECUTE AGREEMENT WITH MICON



obligation assumed by the Contractor hereunder without prior written consent of the CSD Board.

QQ. Workers' Compensation. By my signature hereunder, as Contractor, I certify that I am aware of the provisions of Section 3700 of the Labor Code which require every employer to be insured against liability for Workers' Compensation or to undertake self-insurance in accordance with the provisions of that code, and I will comply with such provisions before commencing the performance of the work of this Agreement. Contractor agrees to waive its statutory immunity under any workers' compensation or similar statute, as respecting the Agency, and to require any and all subcontractors and any other person or entity involved in the Project to do the same.

RR. Independent Contractor Waiver and Civil Code Section 1542 Waiver. Contractor expressly waives any claims for any compensation or benefits afforded to CSD and/or City employees and not to independent contractors, and waives any and all rights and benefits conferred upon it by the provisions of section 1542 of the California Civil Code which reads as follows:

“A general release does not extend to claims which the creditor does not know or suspect to exist in his or her favor at the time of executing the release, which if known by him or her must have materially affected his or her settlement with the debtor.”

This waiver shall be effective as a bar to any and all actions, fees, damages, losses, claims, liabilities and demands of whatsoever character, nature and kind that are known or unknown, or suspected or unsuspected, including, without limitation, claims of entitlements under the California Public Employees' Retirement System (CalPERS) that are only afforded to employees and not independent contractors. Contractor further represents and warrants that it understands this waiver and that if it does not understand this waiver, it shall seek the advice of a qualified attorney before executing this Agreement.

  
Initials

SS. Acceptance of Work. Acceptance of the work shall be by action of the Agency's CSD Board or its designee. Neither the acceptance nor prior inspections or failure to inspect shall constitute a waiver by the Agency of any defects in the work. From and after acceptance, the work shall be owned and operated by the Agency. As a condition to acceptance, Contractor shall certify to the Agency in writing that all of the work has been performed in strict conformity with this Agreement and that all costs have been paid, satisfactorily to the Agency, guaranteeing such performance.

TT. Licensing. Contractors are required by law to be licensed and regulated by the Contractors' State License Board. Any questions concerning a Contractor may be referred to the Registrar, Contractors' State License Board, 3132 Bradshaw Road, Sacramento, CA 95826. Mailing address: P.O.Box 26000, Sacramento, CA 95826.

UU. City of Moreno Valley Business License. The Contractor and all subcontractors shall obtain and keep current a valid City of Moreno Valley Business License and all professional licenses, certifications and/or permits necessary for performing the services describe in this Agreement prior to commencement and throughout the term of this Agreement.

VV. Default.  
1. Failure or delay by any party to this Agreement to perform any material term or provision of this Agreement shall constitute a default under this Agreement; provided

Attachment: Micon Agreement - COMMUNITY PARK SKATE PARK [Revision 1] (3355 : APPROVE AND EXECUTE AGREEMENT WITH MICON

however, that if the party who is otherwise claimed to be in default by the other party commences to cure, correct or remedy the alleged default within fifteen (15) days after receipt of written notice specifying such default and diligently completes such cure, correction or remedy, such party shall not be deemed to be in default hereunder.

2. The party which may claim that a default has occurred shall give written notice of default to the party in default, specifying the alleged default. Delay in giving such notice shall not constitute a waiver of any default nor shall it change the time of default; provided, however, the injured party shall have no right to exercise any remedy for a default hereunder without delivering the written default notice, as specified herein.

3. Any failure or delay by a party in asserting any of its rights or remedies as to any default shall not operate as a waiver of any default or of any rights or remedies associated with a default.

4. In the event that a default of any party to this Agreement may remain uncured for more than fifteen (15) days following written notice, as provided above, a "breach" shall be deemed to have occurred. In the event of a breach, the injured party shall be entitled to seek any appropriate remedy or damages by initiating legal proceedings.

WW. Cumulative Remedies. Except with respect to rights and remedies expressly declared to be exclusive in this Agreement, the rights and remedies of the parties are cumulative and the exercise by either party of one or more of such rights or remedies shall not preclude the exercise by it, at the same or different times, of any other rights or remedies for the same default of any other default by the other party.

XX. Conflicts of Interest. Contractor covenants that it does not have any interest, nor shall it acquire an interest, directly or indirectly, which would conflict in any manner with the performance of Contractor's services under this Agreement. In the event the Agency officially determines that Contractor must disclose its financial interests by completing and filing a Fair Political Practices Commission Form 700, Statement of Economic Interests, Contractor shall file the subject Form 700 with City Hall, as specified under the Notice provisions of this Agreement, pursuant to the written instructions provided by the Agency.

YY. Delivery of Notices. All notices permitted or required under this Agreement shall be given to the respective parties at the following address, or at such other address as the respective parties may provide in writing for this purpose:

**Contractor:**

**Micon Construction  
1616 Sierra Madre Circle  
Placentia, CA 92870  
Business Phone: 800-949-0203  
Attn: Kim Garrigues**

**Agency:**

**Parks and Community Services  
14177 Frederick St  
Post Office Box 88005  
Moreno Valley, CA 92552-0805  
Attn: Tony Hetherman**

Such notice shall be deemed made when personally delivered or when mailed, forty-eight (48) hours after deposit in the U.S. Mail, first class postage prepaid and addressed to the party at its applicable address. Actual notice shall be deemed adequate notice on the date actual notice occurred, regardless of the method of service.

Attachment: Micon Agreement - COMMUNITY PARK SKATE PARK [Revision 1] (3355 : APPROVE AND EXECUTE AGREEMENT WITH MICON

- ZZ. Time of Essence. Time is of the essence for each and every provision of this Agreement.
- AAA. Agency's Right to Employ Other Contractors.
1. The Agency reserves the right to employ other contractors in connection with work ancillary to the Project. The Contractor shall be responsible for ascertaining the nature and extent of any simultaneous, collateral, and essential work by others and coordinating with the work by others. The Agency, other contractors and utilities shall have the right to operate within or adjacent to the Project site during the performance of such work.
  2. Should construction be under way by other forces or by other contractors within or adjacent to the limits of the work specified or should work of any other nature be under way by other forces within or adjacent to those limits, the Contractor shall cooperate with all the other contractors or other forces to the end that any delay or hindrance to their work will be avoided. The right is reserved to perform other or additional work at or near the site (including material sources) at any time, by the use of other forces.
- BBB. Amendment; Modification. No supplement, modification, or amendment of this Agreement shall be binding unless executed in writing and signed by both parties.
- CCC. Waiver. No waiver of any default shall constitute a waiver of any other default or breach, whether of the same or other covenant or condition. No waiver, benefit, privilege, or service voluntarily given or performed by a party shall give the other party any contractual rights by custom, estoppel, or otherwise.
- DDD. No Third Party Beneficiaries. There are no intended third party beneficiaries of any right or obligation assumed by the parties, nor shall any provision of this Agreement be so construed.
- EEE. Counterparts. This Agreement may be signed in counterparts, each of which shall constitute an original. All electronic signatures shall be deemed to be one and the same as original signatures.
- FFF. Invalidity; Severability. If any portion of this Agreement is declared invalid, illegal, or otherwise unenforceable by a court of competent jurisdiction, the remaining provisions shall continue in full force and effect; and, to the extent permitted and possible, the invalid or unenforceable term shall be deemed replaced by a term that comes closest to expressing the intention of such invalid or unenforceable term.
- GGG. Assignment or Transfer. Contractor shall not assign, hypothecate, or transfer, either directly or by operation of law, this Agreement or any interest herein without the prior written consent of the Agency. Any attempt to do so shall be null and void, and any assignees, hypothecates or transferees shall acquire no right or interest by reason of such attempted assignment, hypothecation or transfer.
- HHH. Bonds (applicable when Project exceeds \$25,000.00), (Exhibit C)
1. Performance Bond. The Contractor shall furnish a satisfactory Performance Bond meeting all statutory requirements of the State of California on the form provided by the Agency. The bond shall be furnished as a guarantee of the faithful performance of the requirements of this Agreement as may be amended from time to time, including, but not limited to, for protection against liability for delays and damages (both direct and consequential) to the Agency and the Agency's consultants and other contractors, and to ensure all warranties, guarantees, and indemnity obligations, in an amount that shall remain equal to one hundred percent (100%) of the compensation to be paid Contractor under this Agreement. The Performance Bond shall remain in force until at least two (2) years after the date of final acceptance of the Project, unless the City determines, in its sole and absolute discretion, to release the Performance Bond earlier and notifies Contractor in writing.

2. Labor and Materials Payment Bond. The Contractor shall furnish a satisfactory Labor and Materials Payment Bond meeting all statutory requirements of the State of California on the form provided by the Agency in an amount that shall remain equal to one hundred percent (100%) of the compensation to be paid Contractor under this Agreement to secure payment of all claims, demands, stop notices, or charges of material suppliers, mechanics, or laborers employed by the Contractor or by any subcontractor, or any person, firm, or entity eligible to file a stop payment notice with respect to the Project. The Labor and Materials Payment Bond shall remain in force and shall not be released until at least seven (7) months after the date of recordation of the Notice of Completion or Notice of Acceptance, whichever occurs first.

3. Bond Requirements.

a. All bonds shall be executed by a California-admitted surety insurer. Bonds issued by a California-admitted surety insurer listed on the latest version of the U.S Department of Treasury Circular 570 shall be deemed accepted unless specifically rejected by the Agency. Bonds issued by sureties not listed in Treasury Circular 570 must be accompanied by all documents enumerated in California Code of Civil Procedure Section 995.660(a). The bonds shall bear the same date as the Agreement. The attorney-in-fact who executes the required bonds on behalf of the surety shall affix thereto a certified and current copy of the power of attorney. In the event of changes that increase the Agreement compensation, the amount of each bond shall be deemed to increase and at all times remain equal to the Agreement amount. The signatures shall be acknowledged by a notary public. Every bond must display the surety's bond number and incorporate by reference the Agreement and the obligations to complete the Project in accordance with the Agreement. The terms of the bonds shall provide that the surety agrees that no change, extension of time, alteration, or modification of the Agreement or the work to be performed thereunder shall in any way affect its obligations and shall waive notice of any such change, extension of time, alteration, or modification of the Agreement. The surety further agrees that it is obligated under the bonds to any successor, grantee, or assignee of the Agency.

b. Upon the request of any person or entity appearing to be a potential beneficiary of bonds covering payment of obligations arising under the Agreement, the Contractor shall promptly furnish a copy of the bonds or shall authorize a copy to be furnished.

c. Should any bond become insufficient, or should any of the sureties, in the opinion of the Agency, become non-responsible or unacceptable, the Contractor shall, within ten (10) calendar days after receiving notice from the Agency, provide written documentation to the satisfaction of the Agency that Contractor has secured new or additional sureties for the bonds; otherwise the Contractor shall be in default of the Agreement. No further payments shall be deemed due or will be made under the Agreement until a new surety(ies) qualifies and is accepted by the Agency.

III. Non-Liability of City or CSD's Officers and Employees. No officer or employee of the City or CSD shall be personally liable to Consultant, or any successor in interest, in the event of any default or breach by the Agency or for any amount which may become due to Consultant or to its successor, or for any breach of any obligation of the terms of this Agreement.

**SIGNATURE PAGE TO FOLLOW**

Attachment: Micon Agreement - COMMUNITY PARK SKATE PARK [Revision 1] (3355 : APPROVE AND EXECUTE AGREEMENT WITH MICON

IN WITNESS HEREOF, the parties have each caused their authorized representative to execute this Agreement.

**Moreno Valley Community Services District**

**Micon Construction Inc.**

By: \_\_\_\_\_  
**Thomas M. DeSantis**  
**Executive Director**

By: \_\_\_\_\_  
**Mitch Holle**

Title: \_\_\_\_\_  
**President**

Date: \_\_\_\_\_

Date: \_\_\_\_\_

RECOMMENDED FOR APPROVAL:

By: \_\_\_\_\_  
**Mariia Los**

\_\_\_\_\_  
**Patti Solano**  
Director, Parks and Community Services

Title: \_\_\_\_\_  
**Secretary**

Date: \_\_\_\_\_

Date: \_\_\_\_\_

\_\_\_\_\_  
**Tony Hetherman**  
Parks Projects Coordinator

Date: \_\_\_\_\_

APPROVED AS TO LEGAL FORM:

\_\_\_\_\_  
City Attorney

Date: \_\_\_\_\_

Signature(s) must be accompanied by a completed notary certificate of acknowledgement attached hereto. **Two (2)** corporate officers must sign on behalf of a corporation unless the corporation has a corporate resolution that allows one person to sign on behalf of the corporation; if applicable, said resolution must be attached hereto. The corporate seal may be affixed hereto. **The contract shall be notarized**

Attachments

- Exhibit A: Agency – Services to be provided to Contractor
- Exhibit B: Terms of Payment
- Exhibit C: Bond Forms
- Exhibit D: Bid Documents, Addenda, Special Provisions

Attachment: Micon Agreement - COMMUNITY PARK SKATE PARK [Revision 1] (3355 : APPROVE AND EXECUTE AGREEMENT WITH MICON

**EXHIBIT A**  
**SERVICES TO BE PROVIDED**  
**TO CONTRACTOR**

1. Furnish the Contractor all in-house data which is pertinent to services to be performed by the Contractor and which is within the custody or control of the Agency, including, but not limited to, copies of record and off-record maps and other record and off-record property data, right-of-way maps and other right-of-way data, pending or proposed subject property land division and development application data, all newly developed and pertinent design and project specification data, and such other pertinent data which may become available to the Agency.
2. Provide timely review, processing, and reasonably expeditious approval of all submittals by the Contractor.
3. Provide timely Agency staff liaison with the Contractor when requested and when reasonably needed.

Attachment: Micon Agreement - COMMUNITY PARK SKATE PARK [Revision 1] (3355 : APPROVE AND EXECUTE AGREEMENT WITH MICON

**EXHIBIT B**

**TERMS OF PAYMENT**

1. The Agency will pay the Contractor and the Contractor agrees to receive and accept the prices set forth in the Bid Schedule as full compensation for the work required under the bid items awarded by the Agency, to wit, the **Base Bid** Item(s) in the sum total amount of **FIVE HUNDRED FOURTY-SIX THOUSAND, FIVE HUNDRED TWENTY-THREE, and 00/100 DOLLARS (\$546,523.00)**, subject to additions or reductions of the quantities of the various bid items at the unit prices bid, for furnishing all materials and for doing all the work contemplated and embraced under this Agreement; for all loss or damages arising out of the nature of the work aforesaid, or from the action of the elements, or from any unforeseen difficulties or obstructions which may arise or be encountered in the prosecution of the work, until the work is accepted by the Board of Directors; for all expenses incurred by or in consequence of the suspension or discontinuance of work; and for well and faithfully completing the work, the whole thereof, in the manner and in accordance with the Bid Documents therefore and the requirements of the Engineer under them.
2. A contingency of **FIFTY THOUSAND and 00/100 DOLLARS (\$50,000.00)** is added to the project's base bid. The contingency shall only be utilized with approval of the Director or his/her designee for items foreseen and/or unforeseen that have been added to the project by the Agency. All requests shall be documented in writing. (ONLY IF THERE IS A CONTINGENCY)
3. The Contractor will obtain, and keep current during the term of this Agreement, the required City of Moreno Valley business license. Proof of a current City of Moreno Valley business license will be required prior to any payments by the Agency. Any invoice not paid because the proof of a current City of Moreno Valley business license has not been provided will not incur any fees, late charges, or other penalties. Complete instructions for obtaining a City of Moreno Valley business license are located at: [http://www.moval.org/do\\_biz/biz-license.shtml](http://www.moval.org/do_biz/biz-license.shtml)
4. The Contractor shall meet with the Director or his/her designee monthly, prior to billing, to review and agree on quantities and work performed.
5. The Contractor will electronically submit an invoice to the Agency as provided in this Agreement for progress payments along with documentation evidencing services completed to date. The progress payment is based on actual time and materials expended in furnishing authorized professional services since the last invoice. At no time will the Agency pay for more services than have been satisfactorily completed and the Agency determination of the amount due for any progress payment shall be final. The Contractor will submit all original invoices to Accounts Payable staff at [AccountsPayable@moval.org](mailto:AccountsPayable@moval.org) and to Tony Hetherman at [tonyh@moval.org](mailto:tonyh@moval.org).
6. Accounts Payable questions can be directed to 951.413.3087.
7. Questions regarding invoicing, quantities, and/or labor can be directed to Tony Hetherman at 951.413.3163.
8. The Contractor agrees that Agency payments will be received via Automated Clearing House (ACH) Direct Deposit and that the required ACH Authorization form will be completed prior to any payments by the Agency. Any invoice not paid because the completed ACH Authorization Form has not been provided will not incur any fees, late charges, or other penalties. The ACH Authorization Form is located at: [http://www.moval.org/city\\_hall/forms.shtml#bf](http://www.moval.org/city_hall/forms.shtml#bf)

Attachment: Micon Agreement - COMMUNITY PARK SKATE PARK [Revision 1] (3355 : APPROVE AND EXECUTE AGREEMENT WITH MICON

- 9. The minimum information required on all invoices is:
  - A. Vendor Name, Mailing Address, and Phone Number
  - B. Invoice Date
  - C. Vendor Invoice Number
  - D. City-provided Reference Number (e.g. Project, Activity, and Purchase Order No.)
  - E. Detailed work hours by class title (e.g. Manager, Technician, or Specialist), services performed and rates, explicit portion of a contract amount, or detailed billing information that is sufficient to justify the invoice amount; single, lump amounts without detail are not acceptable.
  
- 10. The Agency shall pay the Contractor for all invoiced, authorized professional services within thirty (30) days of receipt of the invoice for same, provided the services reflected in the invoice were performed to the reasonable satisfaction of the Agency in accordance with the terms of this Agreement.
  
- 11. Pursuant to Public Contract Code section 9203, the Agency shall retain no less than five (5) percent of the compensation to be paid to Contractor which shall be released to the Contractor no later than sixty (60) days from the date of the Agency's acceptance of the work pursuant to this Agreement.

Attachment: Micon Agreement - COMMUNITY PARK SKATE PARK [Revision 1] (3355 : APPROVE AND EXECUTE AGREEMENT WITH MICON



**EXHIBIT C**  
**BONDS**

Attachment: Micon Agreement - COMMUNITY PARK SKATE PARK [Revision 1] (3355 : APPROVE AND EXECUTE AGREEMENT WITH MICON

BOND NO. \_\_\_\_\_

**FAITHFUL PERFORMANCE BOND  
(100% of Total Contract Price)**

**Moreno Valley Community Services District of the City of Moreno Valley  
COMMUNITY PARK SKATE PARK  
PROJECT NO. 807-0048**

KNOW ALL MEN AND WOMEN BY THESE PRESENTS:

THAT WHEREAS, the Moreno Valley Community Services District of the City of Moreno Valley, County of Riverside, State of California, known as "CSD," has awarded to **MICON CONSTRUCTION** as Principal hereinafter designated as "Contractor" and have entered into an Agreement whereby the Contractor agrees to construct or install and complete certain designated public improvements, which said Agreement, effective on the date signed by the **Executive Director**, and identified as **Project No. 807-0048**, and all Contract Documents are hereby referred to and made a part hereof; and

WHEREAS, said Contractor under the terms of said Contract Documents is required to furnish a bond guaranteeing the faithful performance of said Agreement;

NOW THEREFORE, we the undersigned Contractor and \_\_\_\_\_ as Surety are held and firmly bound unto the Moreno Valley Community Services District of the City of Moreno Valley, County of Riverside in the penal sum of **FIVE HUNDRED FORTY-SIX THOUSAND, FIVE HUNDRED TWENTY-THREE, and 00/100 DOLLARS (\$546,523.00)**, lawful money of the United States, to be paid to the said CSD or its certain attorney, its successors and assigns; for which payment, well and truly to be made, we bind ourselves, our heirs, executors and administrators, successors and assigns, jointly and severally liable (CCP 995.320 (a)(1)), firmly by these presents.

THE CONDITION OF THIS OBLIGATION IS SUCH, that if the above bound Contractor, his or her or its heirs, executors, administrators, successors or assigns, shall in all things stand to and abide by, and well and truly keep and perform the covenants, conditions and provisions in said Contract Documents and any alterations thereof made as therein provided, on his or her or their part, to be kept and performed at the time and in the manner therein specified, and in all respects according to their true intent and meaning, and shall indemnify and save harmless the CSD, its officers, agents and employees, as therein stipulated, then this obligation shall become null and void; otherwise it shall be and remain in full force and effect. In the event suit is brought upon this bond by the CSD and judgement is recovered, the Surety shall pay all costs incurred by the CSD in such suit, including a reasonable attorney fee to be fixed by the court.

The Surety hereby stipulates and agrees that no change, extension of time, alteration, or addition to the terms of the Contract Documents or to the Work to be performed thereunder, or the Provisions accompanying the same shall in any way affect its obligations on this bond, and it does hereby waive notice of any such change, extension of time, alteration or addition to the terms of the Contract Documents or to the Work or the Provisions.

**(SIGNATURE PAGE FOLLOWS)**

Attachment: Micon Agreement - COMMUNITY PARK SKATE PARK [Revision 1] (3355 : APPROVE AND EXECUTE AGREEMENT WITH MICON

BOND NO. \_\_\_\_\_

IN WITNESS WHEREOF, we have hereunto set our hands and seals on this \_\_\_\_\_ day of \_\_\_\_\_ 20\_\_\_\_\_.

CONTRACTOR (Principal)

SURETY

Contractor Name: \_\_\_\_\_

Name: \_\_\_\_\_

Address: \_\_\_\_\_

Address: \_\_\_\_\_

\_\_\_\_\_

\_\_\_\_\_

Telephone No.: \_\_\_\_\_

Telephone No.: \_\_\_\_\_

Print Name: \_\_\_\_\_

Print Name: \_\_\_\_\_

Attorney-in-Fact

Signature: \_\_\_\_\_

Signature: \_\_\_\_\_

Approved as to Form this

\_\_\_\_\_ day of \_\_\_\_\_ 20\_\_\_\_\_

\_\_\_\_\_  
City Attorney  
City of Moreno Valley

**NOTE:**

- The bond shall be executed by a California admitted surety insurer (CCP 995.311).
- The bond shall include an attached Notary Certificate for the Attorney-in-Fact.
- The bond shall include an attached Notary Certificate for the Contractor.
- The bond shall include an attached original Power of Attorney only authorizing the Attorney-in-Fact to act for the Surety.
- The bond shall include the address at which the Principal (Contractor) and Surety may be served with notices, papers and other documents.
- The Bidder's and Surety's corporate seal may be affixed hereto.

Attachment: Micon Agreement - COMMUNITY PARK SKATE PARK [Revision 1] (3355 : APPROVE AND EXECUTE AGREEMENT WITH MICON

BOND NO. \_\_\_\_\_

**LABOR AND MATERIALS PAYMENT BOND  
(100% of Total Contract Amount)**

**Moreno Valley Community Services District of the City of Moreno Valley  
COMMUNITY PARK SKATE PARK  
PROJECT NO. 807-0048**

KNOW ALL MEN AND WOMEN BY THESE PRESENTS

THAT WHEREAS, the Moreno Valley Community Services District of the City of Moreno Valley, County of Riverside, State of California, known as "CSD," has awarded to **MICON CONSTRUCTION** as Principal hereinafter designated as "Contractor" and have entered into an Agreement whereby the Contractor agrees to construct or install and complete certain designated public improvements, which said Agreement, effective on the date signed by the **Executive Director**, and identified as **Project No. 807-0048**, and all Contract Documents are hereby referred to and made a part hereof; and

WHEREAS, said Contractor under the terms of said Contract Documents is required to furnish a bond to secure the payment of claims of laborers, mechanics, materialmen, and other persons, as provided by law;

NOW THEREFORE, we the undersigned Contractor and \_\_\_\_\_ as Surety are held and firmly bound unto the Moreno Valley Community Services District of the City of Moreno Valley, County of Riverside in the penal sum of **FIVE HUNDRED FORTY-SIX THOUSAND, FIVE HUNDRED TWENTY-THREE, and 00/100 DOLLARS (\$546,523.00)**, lawful money of the United States, to be paid to the said CSD or its certain attorney, its successors and assigns; for which payment, well and truly to be made, we bind ourselves, our heirs, executors and administrators, successors and assigns, jointly and severally liable (CCP 995.320 (a)(1)), firmly by these presents.

THE CONDITION OF THIS OBLIGATION IS SUCH, that if said Contractor, his or her or its heirs, executors, administrator, successors or assigns, or subcontractors, shall fail to pay any of the persons described in the State of California Civil Code, Section 3181, or amounts due under the Unemployment Insurance Code with respect to work or labor performed by any such claimant, or any amounts required to be deducted, withheld, and paid over to the Franchise Tax Board from the wages of employees of the Contractor and his or her subcontractors, pursuant to Section 13020, of the Unemployment Insurance Code, with respect to such work and labor, that the Surety or Sureties herein will pay for the same in an amount not exceeding the sum specified in this bond, otherwise the above obligation shall be void. In the event suit is brought upon this bond by the CSD or other person entitled to bring such an action and judgement is recovered, the Surety shall pay all costs incurred by the CSD in such suit, including a reasonable attorney fee to be fixed by the court.

This bond shall inure to the benefit of any of the persons described in the State of California Civil Code Section 3181, to give a right of action to such persons or their assigns in any suit brought upon this bond.

**(SIGNATURE PAGE FOLLOWS)**

Attachment: Micon Agreement - COMMUNITY PARK SKATE PARK [Revision 1] (3355 : APPROVE AND EXECUTE AGREEMENT WITH MICON

BOND NO. \_\_\_\_\_

IN WITNESS WHEREOF, we have hereunto set our hands and seals on this \_\_\_\_\_ day of \_\_\_\_\_ 20\_\_\_\_.

CONTRACTOR (Principal)

SURETY

Contractor Name: \_\_\_\_\_

Name: \_\_\_\_\_

Address: \_\_\_\_\_

Address: \_\_\_\_\_

\_\_\_\_\_

\_\_\_\_\_

Telephone No.: \_\_\_\_\_

Telephone No.: \_\_\_\_\_

Print Name: \_\_\_\_\_

Print Name: \_\_\_\_\_

Attorney-in-Fact

Signature: \_\_\_\_\_

Signature: \_\_\_\_\_

Approved as to Form this

\_\_\_\_\_ day of \_\_\_\_\_ 20\_\_\_\_

\_\_\_\_\_  
City Attorney  
City of Moreno Valley

**NOTE:**

- The bond shall be executed by a California admitted surety insurer (CCP 995.311).
- The bond shall include an attached Notary Certificate for the Attorney-in-Fact.
- The bond shall include an attached Notary Certificate for the Contractor.
- The bond shall include an attached original Power of Attorney only authorizing the Attorney-in-Fact to act for the Surety.
- The bond shall include the address at which the Principal (Contractor) and Surety may be served with notices, papers and other documents.
- The Bidder's and Surety's corporate seal may be affixed hereto.

Attachment: Micon Agreement - COMMUNITY PARK SKATE PARK [Revision 1] (3355 : APPROVE AND EXECUTE AGREEMENT WITH MICON



**CITY OF MORENO VALLEY  
PARKS AND COMMUNITY SERVICES DEPARTMENT**

**Bid No. 2019-034  
COMMUNITY PARK SKATE PARK  
13380 Frederick Street, Moreno Valley, CA 92553**

**November 21, 2018**

Attachment: REQUEST FOR BID 2019-034 - MVCP SKATE PARK (3355 : APPROVE AND EXECUTE AGREEMENT WITH MICON CONSTRUCTION

TABLE OF CONTENTS

| <u>Title</u>   | <u>Page</u>               |
|--|---------------------------|
| <u>Table of Contents</u>   | <u>2</u>                  |
| <u>Preamble</u>  | <u>3</u>                  |
| <u>Notice Inviting Bids</u>  | <u>4-9</u>                |
| <u>Instruction to Bidders</u>  | <u>10-16</u>              |
| <u>Bidder's Proposal</u>   | <u>17-20</u>              |
| <u>Bid Bond</u>  | <u>21-22</u>              |
| <u>California All-Purpose Certificate of Acknowledgment (Sample)</u> | <u>23</u>                 |
| <u>Contractor's Statement</u>  | <u>24-34</u>              |
| <br><b><u>Separate Documents</u></b>                                 |                           |
| <u>Sample Bid Documents</u>  | <u>1 – 26</u>             |
| <u>Special Provisions - General</u>                                  | <u>0701-1 – 0701-79</u>   |
| <u>Special Provisions – Part 2 Technical</u>                         | <u>0702-80 – 0702-153</u> |
| <u>Special Provisions - Appendices</u>                               | <u>0800-81 – 0800-109</u> |
| <u>Project Plans and Related Documents</u>                           |                           |

**BID DOCUMENTS****Bid No. 2019-034***For***MORENO VALLEY COMMUNITY PARK  
SKATE PARK  
13380 Frederick Street, Moreno Valley, CA 92553****PREAMBLE**

The City Special Provisions contained herein supplement and/or modify the General Provisions and Technical Provisions of the Standard Specifications for Public Works Construction ("Greenbook") latest edition. The City Special Provisions are arranged in accordance with the numbering format used in the Standard Specifications, with subsections added where necessary.

**Each and every provision of law required to be inserted in the Bidding Documents shall be deemed to be inserted therein, and the Bidding Documents shall be read and enforced as though it were included therein.**



## NOTICE INVITING BIDS

NOTICE IS HEREBY GIVEN THAT THE CITY OF MORENO VALLEY hereinafter referred to as “the City” or “City,” will receive electronic bids **prior to** the Bid Deadline established below, for the Contract for construction of the Work generally described as:

### MORENO VALLEY COMMUNITY PARK “SKATE PARK” 13380 Frederick Street, Moreno Valley, CA 92553

**Place for Receipt of Bids:** Bids shall be received electronically only on the City of Moreno Valley Bid Portal through PlanetBids. The link to register to become a prospective bidder and electronically bid on this project can be found at the following address:

<https://www.planetbids.com/portal/portal.cfm?CompanyID=24660>

**Pre-Submittal Meeting:** A pre-submittal meeting will be held on **4<sup>th</sup> day of December, 2018 @ 10:00 a.m., PST** located at Moreno Valley Community Park, 13380 Frederick St., Moreno Valley, CA 92553.

Companies wishing to submit a bid for this project are strongly encouraged to attend.

**Requests for Information Deadline:** Date/Time: **December 7, 2018 before 2:00 p.m., PST**

All requests for information must be submitted via the City of Moreno Valley Bid Portal through PlanetBids. Any RFI received after the date and time specified herein will not be considered.

**Bid Deadline:** **December 17, 2018 before 2:00 p.m., PST**

1. **Date of Commencement and Time for Completion:** The Contractor shall complete all preconstruction requirements, ordering of materials, and construction of the Project within the Contract Time of **Ninety (90) Working Days** after the date of commencement specified in the Notice to Proceed to Fulfill Preconstruction Requirements and Notice to Proceed with Order of Materials issued by the City. See **Paragraph 2H** of the Agreement for details regarding the initial Notice to Proceed to Fulfill Preconstruction Requirements and Notice to Proceed with Order of Materials and subsequent Notice to Proceed with Construction.
2. **Bidder Information and Addenda:** Each Bidder shall register to become a prospective bidder via the City of Moreno Valley Bid Portal through PlanetBids; Addenda, if any, shall be issued via email through the PlanetBids Bid Portal. It is the Contractor's responsibility to ensure the email utilized in the Portal is current and accurate and it is further the Contractor's responsibility to actively check the Portal and email for the issuance of Addenda. The City reserves the right to extend the Bid Deadline and Bid Opening by issuing an Addendum to Bidders no later than 72 hours prior to the Bid Deadline.
3. **Bid Forms:** Bids shall be made upon the electronic proposal form online from the City of Moreno Valley Vendor Portal through PlanetBids at the above referenced address. Paper copies will not be accepted. The Bid Sheet included in the proposal is provided for reference and defines the basis of bid. The unit prices for each bid item shall be properly entered in the online electronic proposal.

Each Bidder must scan and submit the following documents with its electronic bid on the City's Bidder's Proposal forms:

- a. Contractor's Statement
- b. Bid Bond at Ten Percent (10%) of the Total Bid Price

The bidder may utilize a cashier's or certified check in lieu of a bid bond in the amount of ten percent (10%) of the total bid. If a cashier's or certified check is used, it shall be delivered to the City Clerk in a sealed envelope at 14177 Frederick Street, Moreno Valley, CA 92553 prior to the bid deadline specified herein.

If any Bidder makes any alteration, or otherwise deviates from any of the pre-defined Bidder's Proposal forms, or makes any qualifications of the Bidder's Proposal forms in separate documents submitted with the Bidder's Proposal, the Bid may be considered non-responsive. All Bidders' Proposals shall be evaluated on the basis of the Engineer's estimate of the quantities of Work to be performed.

4. **Bid Security:** Each Bid shall be accompanied by Bid Security, in the form of a certified check, cashier's check, or Bidder's Bond executed by a California-admitted surety insurer (as defined by California Code of Civil Procedure §§ 995.120 and 995.311) in an amount of not less than **ten percent (10%)** of the amount of the total Bid price. Such Bid Security shall guarantee that the Bidder, if his or her Proposal is accepted, will execute the Agreement, secure and furnish proof of Commercial General Liability, Automobile, and Workers' Compensation Insurance as required by the Contract Documents, furnish a Faithful Performance Bond in the amount of one hundred percent (100%) of the total Contract Price, and furnish a Labor and Materials Payment Bond in the amount of one hundred percent (100%) of the total Contract Price, within ten (10) Working Days after the date of the receipt of the Agreement. Failure to execute and furnish said Contract Documents within said 10 days shall be just cause for the annulment of the award and forfeiture of the Bid Security pursuant to the provisions of Section 20172 of the California Public Contract Code. The City will request the

original bid bonds of the three lowest bidders to be provided to the City within 72 hours of the bid deadline and shall retain the Bid Security of the first, second, and third lowest responsible Bidders until such time as the Agreement is executed. The Bid Security submitted by all other Bidders will be released within thirty (30) days after the date of the award of the Contract. Submission of the bid security shall be in accordance with the instructions provided in Paragraph 3, "Bid Forms", contained herein.

- 5. Contractor Registration:** California law (SB854) provides that "A contractor or subcontractor shall not be qualified to bid on, be listed in a bid proposal, subject to the requirements of section 4104 of the Public Contract Code, or engage in the performance of any contract for public work, as defined in this chapter, unless currently registered and qualified to perform work pursuant to Labor Code section 1725.5." Please go to <http://www.dir.ca.gov/Public-Works/PublicWorks.html>, and look under "Contractor Registration" for more information and to register. Pursuant to the above law, no contractor or subcontractor may be listed on a bid proposal for a public works project (submitted on or after April 1, 2015) unless registered with the Department of Industrial Relations pursuant to Labor Code section 1725.5 [with limited exceptions from this requirement for bid purposes only under Labor Code section 1771.1(a)]. Additionally, no contractor or subcontractor may be awarded a contract for public work on a public works project (awarded on or after April 1, 2015) unless registered with the Department of Industrial Relations pursuant to Labor Code section 1725.5. Please go to <https://www.dir.ca.gov/public-works/publicworkssb854faq.html>

**This project is also subject to compliance monitoring and enforcement by the Department of Industrial Relations.** All contractors and subcontractors must furnish electronic certified payroll records directly to the Labor Commissioner (aka Division of Labor Standards Enforcement). **For all new projects awarded on or after April 1, 2015, the contractors and subcontractors must furnish electronic certified payroll records to the Labor Commissioner. As of January 1, 2016: all contractors (except those listed as Exemptions by the DIR) must furnish electronic certified payroll records to the Labor Commissioner in the "eCPR data system".**

The City of Moreno Valley will not accept a bid nor will it contract or subcontract without proof of the contractor or subcontractor's current registration to perform public works pursuant to section 1725.5.

- 6. Claim Resolution Procedures:** Section 9204 of Assembly Bill 626 sets forth the following new procedural requirements for claims submitted by a contractor on a public works project:
- a. A contractor must furnish "reasonable documentation to support the claim."
  - b. Upon receipt of a claim, a public entity must "conduct a reasonable review" and provide a written statement to the contractor within 45 days of receipt of the claim.
  - c. For any undisputed portion of a claim, a public entity must make payment within 60 days of the public entity's issuance of the written statement.
  - d. If the contractor disputes the public entity's written statement, or if the public entity fails to respond, the contractor may demand "an informal conference to meet and confer for settlement of the issues in dispute."
  - e. The public entity must schedule the meet and confer conference within 30 days

of the demand.

f. Within 10 business days following the meet and confer conference, the public entity must provide a written statement identifying the portion of the claim that remains in dispute. Any payment due on an undisputed portion of the claim must be made within 60 days of the meet and confer conference.

g. After the meet and confer conference, any disputed portion of the claim "shall be submitted to non-binding mediation."

h. If mediation is unsuccessful, the parts of the claim that remain in dispute shall be subject to applicable procedures outside Section 9204 (statutory and contractual).

i. Failure of a public entity to respond to a claim within the time periods described in Section 9204 "shall result in the claim being deemed rejected in its entirety."

7. **Contractor's License and Certifications:** No Bid will be accepted from a Bidder who, at the Bid Deadline, is not fully and properly licensed as a contractor in accordance with Chapter 9 of Division 3 of the California Business and Professions Code (Section 7000 et seq.). At the Bid Deadline, the prime Contractor must hold an active Class "A", sufficient to cover all of the work to be performed by the prime Contractor. Failure of the Bidder to obtain proper and adequate license for award of the Contract shall constitute a failure to execute the Contract and shall result in the forfeiture of the Security of the Bidder (PCC 20103.5). All Subcontractors shall be properly licensed at the Bid Deadline.
8. **Owner's Rights Reserved:** Within such limits as may be prescribed by law, the City Council of the City of Moreno Valley reserves the right to reject any and all Bids, to accept, reject or waive any variances or informalities in a Bid or in the bidding, or to accept the Bid or Bids that best serve the interests of the City.
9. **Work Performed by Contractor:** The successful Bidder shall perform, with its own organization, Contract Work amounting to at least 51 percent (51%) of the Contract Price, except that any designated "Specialty Items" may be performed by subcontract and the amount of any such "Specialty Items" may be deducted from the Contract Sum before computing the amount of Work required to be performed by the Contractor. See Subsection 2-3.2, "Self Performance," of the Standard Specifications and City Special Provisions.
10. **Payment of Prevailing Wage Rates:** This Project is subject to the provisions of Labor Code Section 1720 et seq., and the requirements of Title 8 of the California Code of Regulations Section 16000 et seq., which govern the payment of prevailing wages on public works projects. The Director of the Department of Industrial Relations, State of California (DIR) pursuant to the California Labor Code, has determined the general prevailing rates of wages in the locality in which the Work is to be performed. Said rates are on file with the Capital Projects Division of the City of Moreno Valley and copies will be made available to any interested party on request during regular business hours and are also available on the Internet at the California Department of Industrial Relations website: <http://www.dir.ca.gov/dlsr/DPreWageDetermination.htm>. These rates shall be the minimum wage rates for this project. The Contractor shall post a copy of said rates at the job site throughout the period of work on this project. The Contractor shall see that all employees of both the prime Contractor and subcontractors are being paid rates equal to or greater than the said rates. See **Section 7-2.3** of the **City Special Provisions**.

- 11. Substitution of Securities:** Pursuant to California Public Contract Code Section 22300, the Contractor may substitute approved securities for any monies withheld by the City to ensure performance of the Work. At the request and sole expense of the Contractor, securities equivalent to the amount withheld shall be deposited with the City, or with a state or federally chartered bank in California as escrow agent, who shall pay such monies to the Contractor after satisfactory completion of the Contract. Securities eligible for investment under this section shall include those listed in Section 16430 of the Government Code, bank or savings and loan certificates of deposit, interest-bearing demand deposit accounts, and standby letters of credit. The Contractor shall be the beneficial owner of any securities substituted for monies withheld and shall receive any dividends and interest thereon. Alternatively, the Contractor may request that the City, at the expense of the Contractor, make payment of retention earned directly to the escrow agent. Notwithstanding the foregoing, such Contractor shall have thirty (30) Calendar Days following award of the Contract to submit a written request to the City to permit the substitution of securities for retention or payment to an escrow agent; failure to do so shall be deemed a waiver of the right.
- 12. City of Moreno Valley Business License:** The Contractor and all Subcontractors shall obtain and keep current a City of Moreno Valley Business License prior to commencement and throughout the duration of the Work.
- 13. Withdrawal of Bids:** Bids shall remain open and valid for **sixty (60) days** after the Bid Deadline. Bids may be withdrawn electronically on the PlanetBids Vendor Portal prior to the time set for opening of bids. No bid may be withdrawn or changed after the Bid deadline, except as otherwise provided by law. The lowest Bidder may only request relief of its Bid in accordance with Public Contract Code Section 5100 et seq. Each Bidder agrees by submitting a Bid that its Bid shall remain open, is irrevocable, and may not be modified, withdrawn, or cancelled for a period of at least **sixty (60) Calendar Days** after Bid Deadline.
- 14. Contract Award/Alternate Bid Items:** Refer to **Paragraph 19** of the Instructions to Bidders, Award of Contract.
- 15. Subcontractors:** Each Bidder shall submit, in the electronic Bid Form provided in the City of Moreno Valley's bid portal a list of Subcontractors to be used on this Project as required by the Subletting and Subcontracting Fair Practices Act, California Public Contract Code section 4100 et seq.
- 16. Insurance:** All Contractors and Subcontractors must provide the insurance described in **Paragraph 7** of the Agreement.
- 17. Performance and Payment Bonds:** Refer to **Paragraph 23** of the Instructions to Bidders.
- 18. Technical Information:** For technical information relating to the details of this Project and bidding requirements submit all RFI's via the project Q&A tab within the City of Moreno Valley Vendor Portal in <https://www.planetbids.com/portal/portal.cfm?CompanyID=24660>. Any RFI received after the date and time specified herein will not be considered.

The project manager for this project will be:

Tony Hetherman  
Parks Projects Coordinator  
City of Moreno Valley  
Parks and Community Services Department

## INSTRUCTIONS TO BIDDERS

1. **Scope of Project:** The Contractor shall furnish, to the satisfaction of the Engineer, all labor, materials, tools, equipment, and incidentals, unless otherwise specified, to construct and complete the Work in compliance with the Contract Documents, Technical Specifications, Plans, and any Addenda.
2. **General:** Information contained in these Instructions to Bidders is supplemental to information contained in the Notice Inviting Bids. The meanings of all capitalized terms not defined herein are defined in the Standard Specifications or the City Special Provisions.
3. **Examination of Site and Bidding Documents:** The Bidder, at its sole cost and expense, is required to examine carefully the Bidding Documents and the Project site to become fully acquainted with the conditions affecting the Work. The failure of a Bidder to receive or examine any of the Bidding Documents or to inspect the site shall not relieve such Bidder from any obligation with respect to the Bid, the Contract, or the Work required under the Contract Documents. The City assumes no responsibility or liability to any Bidder for, nor shall the City be bound by, any understandings, oral representations or oral agreements of the City's agents, employees or officers concerning the Contract Documents or the Work made prior to execution of the Contract. By submitting a Bid, Bidder represents: (1) that Bidder has read and understands the Bidding Documents; (2) the Bid is made in compliance with the Bidding Documents and is based upon the labor, materials, equipment, and systems required by the Bidding Documents; (3) that Bidder understands that all labor, materials, equipment, and systems to be furnished for the Work shall be furnished for the prices bid; (4) that it has visited the Project site, familiarized itself with the local conditions under which the Work is to be performed; (5) that it is fully experienced, qualified and competent to perform the Work set forth in the Contract Documents; (6) that it shall not damage or endanger and shall preserve and protect adjacent properties; (7) that it is properly equipped, organized and financed to perform the Work; (8) that it is properly permitted and licensed by the California Contractors State Licensing Board to perform the Work; (9) that it has familiarized itself with all conditions bearing upon transportation, disposal, handling and storage of materials; (10) that it has familiarized itself with the availability of labor, water, electric power, and roads; (11) that it has familiarized itself with uncertainties of weather, or similar physical conditions at the Project site; (12) that it has familiarized itself with the character of equipment and facilities needed preliminary to and during performance of the Work; (13) that it has familiarized itself with the staging and material storage constraints of the Project site and surrounding buildings and will confine its staging and storage operations to approved areas; (14) that it will coordinate its construction activities with the other contractors performing work on the Project site, if any, including, but not limited to, any Separate Contractor retained by the City; and (15) that the Bidder has checked figures set forth in the Bid Schedule and understands that neither the City, nor the Moreno Valley Housing Authority, nor the Moreno Valley Community Services District, nor any officer or employee therefore will be responsible for any misunderstandings, errors, or omissions on the part of the Bidder in submitting its Bid.
4. **Urban Runoff:** The Bidder certifies to the City that he/she has trained his/her employees and Subcontractors, if any, for Urban Runoff management and has included sufficient sums in the Bid Price to cover such costs of said training as stipulated in the most current Regional Water Quality Control Board requirements, including the Municipal Separate Storm Sewer System NPDES Permit. The Contractor is responsible for all clean up and payment of all fines levied as

a result of any illegal discharge (as defined in said NPDES permit) occurring as a result of the Contractor's Work and/or operations.

5. **Estimated Quantities:** The estimated quantities set forth in the Bid Schedule are approximate only, and are provided only as a basis for the comparison of Bids. The City does not guarantee, expressly or by implication, that the actual amount of Work will correspond therewith, and reserves the right to increase or decrease the amount of any portion of the Work, or to omit portions of the Work, or delete any Bid Items of Work as may be deemed necessary or advisable by the Engineer. Payment shall be made only for actual quantities of Contract items constructed in accordance with the Contract Documents. See Section 9-3, "Payment," of the Standard Specifications and City Special Provisions.
6. **Interpretation of Bidding Documents:** Discrepancies in and omissions from the Bidding Documents shall, at once, be brought to the attention of the City. If any Bidder contemplating submitting a Bid for the Project is in doubt as to the true meaning of any part of the Bidding Requirements or Contract Documents, or who finds discrepancies, errors or omissions therein or who finds variances in any of the Bidding Documents with Applicable Law, such Bidder may submit a written request for an interpretation or correction thereof to the City via the City's electronic bidding system. All Bidders shall submit such written requests to the City on or before the deadline established in the Notice Inviting Bids unless modified by Addendum (i.e., at least **five (5) Working Days** prior to the Bid Deadline, unless modified by Addendum). Any interpretation or correction will be made only by Addenda duly issued by the City, and a copy of such Addenda will be e-mailed to each Registered Bidder. The City will not be responsible for any other explanations or interpretations. No oral agreement or conversation with any officers, employees, or agents of the City, either before or after execution of the Contract, shall affect or modify any of the terms of obligations contained in any of the Contract Documents.
7. **Addenda:** Before the Bid Deadline, the City may modify the Work, the Bidding Documents, or any portion(s) thereof by the issuance of written Addenda disseminated to all Registered Bidders. All Addenda shall be acknowledged electronically in the Bidder's Proposal submitted within the City's vendor portal and shall become a part of the Contract Documents. The cost of performing Work described in the Addenda shall be included in the Bid. If any Addenda have been issued by the City but are not acknowledged by the Bidder in the Bidder's Proposal, the Bid may be rejected as non-responsive. All Addenda or Bulletins will be issued via email through the Planet Bids Vendor Portal. It is the Contractor's responsibility to ensure the email utilized in the Planet Bids Vendor Portal is current and accurate and it is further the Contractor's responsibility to actively check the email for Addenda or Bulletin updates.
8. **Bid Forms and Submission of Bid:** Bids shall be made upon the electronic proposal online from the City of Moreno Valley Vendor Portal through PlanetBids at the above referenced address. Paper copies will not be accepted. The Bid Sheet included in the proposal is provided for reference and defines the basis of bid. The unit prices for each bid item shall be properly entered in the online electronic proposal.
9. **Bid Schedule:** The Bidder shall set forth for each Bid Item, in the electronic proposal online, a unit price and a total price in the respective spaces provided for this purpose on the Bidder's Proposal form. In the case of unit basis items, the amount set forth under the "Total Price" column shall be the product of the unit price multiplied by the estimated quantity for the item.

In case of discrepancy between the unit price and the total set forth for the item, the unit price shall prevail, except however, that if the amount set forth as a unit price is ambiguous,



unintelligible or uncertain for any reason, or if it is omitted, or is the same amount as the entry in the "Total Price" column, or in the case of lump sum items is not the same amount as the entry in the "Total Price" column, then the amount set forth in the "Total Price" column for the item shall prevail in accordance with the following:

- a. As to the lump sum items, the amount set forth in the "Total Price" column shall be the same amount in the unit price column, otherwise the amount set forth in the "Total Price" column shall prevail. Lump sum items are considered to be a unit of one.
  - b. As to unit basis items, the amount set forth in the "Total Price" column shall be divided by the estimated quantity for the item and the price thus obtained shall be the unit price.
- 10. Withdrawal of Bidder's Proposals** Bids may be withdrawn electronically on the PlanetBids Vendor Portal prior to the time set for opening of bids.
- a. No bid may be withdrawn or changed after the Bid deadline, except as otherwise provided by law. The lowest Bidder may only request relief of its Bid in accordance with Public Contract Code Section 5100 et seq. Each Bidder agrees by submitting a Bid that its Bid shall remain open, is irrevocable, and may not be modified, withdrawn, or cancelled for a period of at least **sixty (60) Calendar Days** after Bid Deadline.
- 11. Bid Security:** As set forth in the Notice Inviting Bids, Each Bid shall be accompanied by a certified check or cashier's check payable to the City of Moreno Valley, or Bidder's Bond executed by the Bidder as principal and a California-admitted surety insurer (as defined by California Code of Civil Procedure §§ 995.120 and 995.311) in an amount of not less than **ten percent (10%)** of the amount of the total Bid price ("Bid Security"). Pursuant to California Public Contract Code Section 20170 & 20171, no Bid shall be considered unless such Bid Security is enclosed therewith. **If the Bidder elects to furnish a Bidder's Bond as his or her Bid security, the Bidder shall scan and upload the Bid Bond, and submit via the electronic vendor portal prior to the bid deadline.**

The City will request the original bid bonds of the three lowest bidders to be provided to the City within 72 hours of the bid deadline and shall retain the Bid Security of the first, second, and third lowest responsible Bidders until such time as the Agreement is executed. A notary certificate for the Bidder's signature shall be attached. The attorney-in-fact for a corporate surety must sign the bond, such signature shall be notarized, and a certified and notarized Power of Attorney duly authorizing the attorney-in-fact to act for the surety shall be submitted with the bond. The bond shall include the address at which the principal (Bidder) and surety may be served with notices, papers and other documents. If any of these items are not submitted with the Bid, the Bid shall be considered non-responsive and will be rejected.

The bidder may utilize a cashier's or certified check in lieu of a bid bond in the amount of ten percent (10%) of the base bid. If a cashier's or certified check is used, it shall be delivered to the City Clerk in a sealed envelope at 14177 Frederick Street, Moreno Valley, CA 92553 prior to the bid deadline specified herein. In the event that the successful Bidder withdraws its Bid prior to the expiration of **sixty (60) Calendar Days** after the Bid Deadline, or attempts to withdraw its Bid when the requirements of Public Contract Code § 5101 et seq. are not met, or refuses or fails to execute the Contract and provide the required bonds and insurance within **ten (10) Working Days** after award of the Contract, the Bid Security shall be retained by the City. In such event, the City may award the Contract for the Work to a responsible Bidder submitting the next lowest responsive Bid or may call for new Bids at the City's sole discretion. Pursuant to Public Contract Code Section 20174, if the Contract is awarded to the next lowest responsible

Bidder, the defaulted Bidder's Bid Security shall be used to cover the difference between the lowest Bid Price and the second lowest Bid Price, and any surplus will be returned to the defaulted Bidder or surety.

12. **Contractor's Statement:** Each Bidder shall scan and submit with its electronic Bid, a Contractor's Statement (which is included within the Bidder's Proposal forms) completed by Bidder. The Contractor's Statements shall not be public records. All information required by the Contractor's Statement shall be completely and fully provided. Any Bid not accompanied by a Contractor's Statement completed with all information required and bearing the signature of the Bidder's duly authorized representative under penalty of perjury may render the Bid non-responsive and rejected. If the City determines that any information provided by a Bidder in the Contractor's Statement is false or misleading, or is so incomplete as to be false or misleading, the City may reject the Bid submitted by such Bidder as being non-responsive. Although the City will be reviewing qualifications, the City shall not apply a relative superiority analysis in making award of the Contract to the lowest responsive responsible Bidder.

13. **Subcontractors:**

**Subcontractor List.** Each Bidder shall submit with its electronic Bid, in the electronic form provided a list of proposed Subcontractors in accordance with the Subletting and Subcontracting Fair Practices Act, Public Contract Code Section 4100 *et seq.* If additive Alternate Bid Items are included in the Bidding Documents, Bidder shall identify Subcontractors performing additive Alternate Bid Items when such Work or combination of base Contract Work and alternate work exceeds one-half of one percent of the total Bid Price.

The City may require the three (3) lowest Bidders to submit other information pertinent to the proposed Subcontractor's quality, fitness, capacity, and experience to satisfactorily perform the Work. Failure to timely submit such additional Subcontractor information shall result in the Bid being deemed non-responsive and the Bid will be rejected by the City.

**Work of Subcontractors.** The organization or arrangements of the Specifications and Plans shall not limit the extent of the Work of the Contract Documents. Accordingly, all Bidders are encouraged to disseminate all of the Specifications, Drawings, and other Contract Documents to all persons or entities submitting sub-bids to the Bidder. The omission of any portion or item of Work from the Bid or from sub-bids that is reasonably inferable from the Contract Documents is not a basis for adjustment of the Contract Price or the Contract Time.

**Bidder-Performed Work.** After the Bid Deadline, the City may require the three (3) lowest Bidders to submit information about Bidder-performed Work including, but not limited to, the dollar value or percentage value of Work to be performed by Bidder in conformity with the Contract Documents. See Subsection 2-3.2, "Self Performance," of the Standard Specifications and City Special Provisions regarding requirements for Contractor-performed Work.

**Ineligible Subcontractors.** The successful Bidder is prohibited from performing Work on the Project with any Subcontractor who is ineligible to perform work on a public works project pursuant to Sections 1777.1 or 1777.7 of the California Labor Code. By submitting a Bid, each Bidder certifies that it has investigated the eligibility of each and every listed Subcontractor and has determined that none is ineligible to perform Work pursuant to the Labor Code.

14. **Non-Collusion Affidavit:** In accordance with California Public Contract Code § 7106, the Bidder shall sign the Declaration of Non-collusion in the form contained in the Bidding Documents, under penalty of perjury, certifying that the Bid is not the result of and has not been influenced by collusion. Any Bid made without such declaration, or believed to be made in violation thereof, shall be deemed non-responsive. **Bidder shall scan and submit with its bid the Non-Collusion form contained herein.**
15. **Disqualification of Bidders:**
16. **Debarred Contractors.** No Bid will be accepted from a Bidder who is prohibited from performing work on a public works project pursuant to Sections 1777.1 or 1777.7 of the California Labor Code.
17. **Interest in More Than One Bid.** More than one Bid from an individual, firm, partnership, corporation, or an association under the same or different name will not be considered; however, a person, firm or corporation that has submitted a sub-bid to a Bidder or that has quoted prices of materials to a Bidder, is not thereby disqualified from submitting a sub-bid or quoting prices to other Bidders or making a Bid as the prime contractor. Reasonable grounds for believing that any Bidder has an interest in more than one Bid as a Bidder will cause the rejection of all Bids in which such Bidder is interested.
18. **Improperly Licensed.** No Bid will be accepted from a Bidder who, at the Bid Deadline, is not fully and properly licensed as a contractor in accordance with Chapter 9 of Division 3 of the California Business and Professions Code (Section 7000 et seq.). See the Notice Inviting Bids for identification of the license(s) required for this Project.
19. **Evaluation of Bids:**
- a. **Responsive Bid.** A responsive Bid is a Bid that conforms, in all material respects, to these Instructions to Bidders. Non-responsive Bids will be rejected.
  - b. **Responsible Bidder.** A responsible Bidder means a Bidder who has demonstrated the attributes of trustworthiness, quality, fitness, capacity, and experience to satisfactorily perform fully the requirements of the Contract Documents and the moral and business integrity and reliability that will assure good faith performance in the sole discretion of the City. The City's determination of a Bidder's responsibility or non-responsibility shall be based on the fitness and capacity of the Bidder to satisfactorily perform the obligations of the Contract, whether or not the Bidder is qualified to perform those obligations, whether or not the Bidder is trustworthy, and such other bases as may be relevant. The City may consider, among other things: (1) any act or omission or pattern or practice of acts or omissions that negatively reflect on the Bidder's quality, fitness or capacity to perform; (2) any act or omission of Bidder that indicates a lack of integrity or honesty; (3) the making of a false claim against the City or any other public entity or engaging in collusion; (4) the Bidder's financial capability to perform; (5) the Bidder's experience with its sureties and insurance companies; (6) the Bidder's ability to perform on time and on budget, either in the present or as performed in the past; (7) whether or not Bidder has performed satisfactorily in the past on its contracts with the City or any other public entity, including, but not limited to, whether or not Bidder has been in default under a contract with the City or any other public entity; (8) the Bidder's safety record; (9) the Bidder's history of claims, litigation, and termination or disqualification on public projects; (10) Bidder's contract management skills, including, but not limited to, the use of scheduling tools, submission of schedules, compliance with prevailing wage rates, and

certification of accurate payroll documents; and (11) whether or not Bidder is currently or was previously debarred by any public agency.

- c. **Reservation of Rights:** The City reserves the right, in its sole discretion, to: judge the Bidder's representations as stated in the Bidder's Proposal forms, including the Contractor's Statement, and any post-Bid information to determine whether or not Bidder is qualified to perform the Work; be the sole judge regarding the suitability of the products, services or supplies offered; to not purchase all items or the full quantity of each item listed in the Bidding Documents; reject any or all Bids; modify, cancel or withdraw the Notice Inviting Bids; issue a new Notice Inviting Bids; suspend or abandon the Project; appoint evaluation committees to review bids; and seek the assistance of outside technical experts in Bid evaluation; waive deficiencies, informalities and minor irregularities in any Bid or in the bidding process; require a Bidder to provide a guarantee (or guarantees) of the Contract by a third party; not issue a Notice to Proceed after execution of the Contract. In submitting a Bid in response to the Notice Inviting Bids, the Bidder is specifically acknowledging the City holds these rights.
- d. The Notice Inviting Bids does not commit the City to enter into a Contract, to reject, in its sole discretion, all Bids, nor does it obligate the City to pay for any costs incurred in preparation and submission of a Bid or in anticipation of a contract. By submitting a Bid, the Bidder disclaims any right to be paid for such costs.
- 20. Rejection of Bidder's Proposals:** Any Bid containing information which is subsequently proven false or improperly signed shall be considered non-responsive and shall be rejected by the City. A Bid **shall** be rejected as non-responsive:
- a. If the Bid shows any alterations of form or material additions not called for.
  - b. If the Bid contains additional or alternate Bid Items not called for.
  - c. If the Bidder adds any provisions reserving its rights to accept or reject any award of Contract.
  - d. If the Bid Bond/Security does not accompany the Bid.
  - e. If the Bid fails to provide required information except as allowed by law.
  - f. If the Bid fails to indicate that Work valued at least fifty percent (50%) of Contract Price (except Specialty Items) will be performed by the Bidder's own forces, in accordance with Section 2-3.2 of the City Special Provisions.
  - g. If the Bid is transferred to another Bidder.
  - h. If the Bid is received after the designated deadline.
  - i. If the Bid is oral, telephoned, faxed, e-mailed, or telegraphed.
  - j. If the Bidder has been debarred pursuant to California Labor Code Sections 1777.1 or 1777.7 (see Paragraph 16.1 above).

A Bid **may** be rejected as non-responsive if it contains irregularities of any kind; however, the City reserves the right to waive irregularities to the extent permitted by law, as well as to reject any and all Bids. Bids may be considered irregular and may be rejected for reasons that include, but are not limited to, the following:

- k. If there are material qualifications, conditions, or irregularities of any kind which may make the Bid incomplete, indefinite, or ambiguous.
  - l. If the Bid Price or unit prices provided by Bidder are obviously unbalanced or are excessive or may materially affect the final cost of the Work.
  - m. If Bidder has been delinquent or unfaithful in the performance of any former contract with the City.
  - n. If the City determines that any information provided by a Bidder is false or misleading, or is so incomplete as to be false or misleading.
- 21. Award of Contract:** The lowest responsible Bidder will be determined by comparing the total Bid Price of all Base Bid Items plus Alternate Bid Items, using the Engineer's estimate of quantities for the Work as set forth in the Bidder's Proposal. The City reserves the right to select any, all, or none of the Alternate Bid Items at the time of award of the Contract. In the event that any or all of the Alternate Bid Items are not awarded as part of the Contract, the City reserves the right to add any or all of the Alternate Bid Items by Change Order or Construction Change Directive at the prices set forth in the Bid. The award of the Contract, if made, will be within sixty (60) Calendar Days after Bid Opening. In the event award is not made within a sixty (60) day period, the selected Contractor, if any, may submit to the City claim(s) for additional costs incurred between the end of said sixty (60) day period and date of actual award. All reasonable claims will be considered, and any justifiable costs shall be added to the Contract pursuant to a Change Order.
- 22. Execution of Contract:** The Agreement shall be signed by the successful Bidder in duplicate counterpart and returned, together with the required bonds and insurance certificate(s), within ten (10) Working Days after the date the Agreement is awarded to the successful Bidder by the City. The Contract shall not be binding upon the City until same has been completely executed by the Contractor and the City.
- 23. Bonds and Insurance:** The successful Bidder shall furnish a Performance Bond and a Labor and Materials Payment Bond, each in the penal amount of 100% of the Contract Price. Bond forms for execution will be provided by the City when the Contract is tendered to the successful Bidder. Bonds may be secured through the Bidder's usual sources. The cost of furnishing the bonds shall be included in the Bid. Bonds issued by a California-admitted surety insurer listed on Treasury Circular 570 shall be deemed accepted unless specifically rejected by the City. Bonds issued by sureties not listed in Treasury Circular 570 must be accompanied by all documents enumerated in California Code of Civil Procedure Section 995.660. The bonds are subject to the requirements of **Paragraph 8** of the Agreement. The Bidder selected for award of the Contract will be required to furnish the City with a certificate of liability insurance coverage, an insurance endorsement, and workers' compensation certification in the coverage amounts specified in **Paragraph 7** of the Agreement. The successful Bidder shall deliver the signed Agreement, bonds, and insurance to the City within **ten (10) Working Days** after the Contract is awarded to the successful Bidder.
- 24. Permits and Fees:** Refer to Section 7-5 of the City Special Provisions.

**BIDDER'S PROPOSAL  
PROJECT NO. 807-0048**

**PROJECT NAME:  
COMMUNITY PARK SKATE PARK**

**CERTIFICATION OF INSPECTION OF THE SITE AND CONTRACT DOCUMENTS.** By submitting an electronic bid, Bidder certifies that it: has carefully examined the location of the proposed Work, is fully familiar with all Contract Documents, including the City Special Provisions, Plans, and Addenda, Plans, and that said Contract Documents contain sufficient detail regarding the Work to be performed; has notified Owner of any errors or omissions in the Contract Documents and unusual site conditions; has carefully checked all words, prices, and statements in this Bidder's Proposal; and has visited the Project site and conducted such other field investigations which are prudent and reasonable in preparing the Bid. Bidder agrees that neither the City of Moreno Valley, nor the Moreno Valley Housing Authority, nor the Moreno Valley Community Services District, nor the City as Successor Agency for the Community Redevelopment Agency of the City of Moreno Valley *for RDA only*, nor the Western Riverside Council of Governments *for TUMF only*, nor any officer or employee therefore will be responsible for any misunderstandings, errors or omissions on the part of the undersigned in submitting this Bid.

**BIDDER'S REPRESENTATIONS REGARDING INSURANCE AND BONDS.** This Bid is made with the full knowledge of the kind, quantity, and quality of the materials and Work required and, if it is accepted by the City, the Bidder shall enter into a Contract and furnish the bonds, insurance, and other documents as required by the Contract Documents within ten (10) Working Days after award of the Contract. The Bidder agrees that failure to execute and return the Agreement or the required faithful performance bond, labor and materials payment bond, and insurance certificates to the City within said ten (10) Working Days shall be sufficient cause for the rescission of the award and forfeiture of the Bid Security.

**TIME FOR COMPLETION.** The Bidder agrees that if awarded the Contract, it shall complete all preconstruction requirements, ordering of materials, and construction of the Project within the Contract Time established in **Paragraph 5** of the Agreement and within the duration(s) established to Fulfill Preconstruction Requirements and to Order Materials.

**NON-COLLUSION AFFIDAVIT.** Bidder being first duly sworn, deposes and says that the party who submits herewith a Bid to the City; that the Bid is not made in the interest of, or on behalf of, any undisclosed person, partnership, company, association, organization, or corporation; that the Bid is genuine and not collusive or sham; that the Bidder has not directly or indirectly induced or solicited any other Bidder to put in a false or sham Bid, and has not directly or indirectly colluded, conspired, connived, or agreed with any Bidder or anyone else to put in a sham Bid, or that anyone shall refrain from bidding; that the Bidder has not in any manner, directly or indirectly sought by agreement, communication, or conference with anyone to fix the Bid price of the Bidder or any other Bidder, or to fix any overhead, profit, or cost element of the Bid price, or of that of any other Bidder, or to secure any advantage against the City of anyone interested in the proposed Contract; that all statements contained in the Bid are true; and, further, that the Bidder has not, directly or indirectly, submitted his or her Bid Price or any breakdown thereof, or the contents thereof, or divulged information or data relative thereto, or paid, and will not pay, any fee to any corporation, partnership, company associations, organization, bid depository, or to any member or agent thereof to effectuate a collusive or sham Bid. **Bidder acknowledges acceptance and agreement with the above by agreeing to the terms and conditions at the time of electronic bid submittal.**

**Bid Schedule shown is for reference purposes only. Bid Schedule must be completed electronically.**

The link to register to become a prospective bidder and electronically bid on this project can be found at the following address: <https://www.planetbids.com/portal/portal.cfm?CompanyID=24660>

**City of Moreno Valley will purchase the following items directly from the manufacturer:**

- Shade structure material **and** installation
- Synthetic turf **and** installation
- Light poles and fixtures (material only)

**Refer to construction plan for notes regarding coordination with city and manufacturers.**

**BIDDER'S PROPOSAL - BID SCHEDULE**  
**PROJECT NO. 807-0048**  
**MORENO VALLEY COMMUNITY PARK SKATE PARK**

**BASE BID ITEMS AS FOLLOWS:**

|                     | DESCRIPTION OF ITEMS PER PLANS AND SPECIFICATIONS | QTY | UNIT | UNIT COST | TOTAL COST |
|---------------------|---|-----|------|-----------|------------|
| <b>MOBILIZATION</b> |   |     |      |           |            |
| 1                   | MOBILIZATION AND DEMOBILIZATION                   | 1   | LS   |           |            |
| 2                   | PORTABLE RESTROOM                                 | 1   | LS   |           |            |
| 3                   | STORAGE CONTAINER                                 | 1   | LS   |           |            |
| 4                   | TEMPORARY FENCING                                 | 1   | LS   |           |            |
| 5                   | TEMPORARY WATER AND POWER FOR CONSTRUCTION        | 1   | LS   |           |            |
| 6                   | EROSION AND DUST CONTROL                          | 1   | LS   |           |            |
| 7                   | TREE PROTECTION                                   | 1   | LS   |           |            |
| 8                   | INSURANCE AND BONDING                             | 1   | LS   |           |            |
| 9                   | AS-BUILTS   | 1   | LS   |           |            |
| 10                  | SUBMITTALS  | 1   | LS   |           |            |
| 11                  | CONSTRUCTION STAKING                              | 1   | LS   |           |            |

**MOBILIZATION TOTAL** \_\_\_\_\_

| <b>DEMOLITION AND GRADING</b> |  |       |    |  |  |
|-------------------------------|--|-------|----|--|--|
| 12                            | REMOVAL AND DISPOSAL OF EXISTING GRASS           | 19150 | SF |  |  |
| 13                            | REMOVAL AND DISPOSAL OF EXISTING CONCRETE PAVING | 360   | SF |  |  |
| 14                            | ROUGH GRADING                                    | 1     | LS |  |  |
| 15                            | FINE GRADING                                     | 1     | LS |  |  |
| 16                            | COMPACTION TESTING FOR CONCRETE SUBGRADE         | 1     | LS |  |  |

**DEMOLITION AND GRADING TOTAL** \_\_\_\_\_

| <b>HARDSCAPE</b> |   |     |    |  |  |
|------------------|---|-----|----|--|--|
| 17               | 4" THICK NATURAL GRAY CONCRETE PAVING           | 360 | SF |  |  |
| 18               | CONCRETE MOW CURB                               | 120 | LF |  |  |
| 19               | STEEL - GRIND RAILS, COPING AND EDGE PROTECTION | 1   | LS |  |  |
| 20               | CONCRETE SKATE ELEMENTS                         | 1   | LS |  |  |
| 21               | CONCRETE FLATWORK AND TURNDOWN WALLS            | 1   | LS |  |  |
| 22               | COORDINATION WITH SYNTHETIC TURF CONTRACTOR     | 1   | LS |  |  |

**HARDSCAPE TOTAL** \_\_\_\_\_

| <b>SITE STRUCTURES</b> |  |   |    |  |  |
|------------------------|--|---|----|--|--|
| 23                     | COORDINATION WITH SHADE STRUCTURE CONTRACTOR | 1 | LS |  |  |

**SITE STRUCTURES TOTAL** \_\_\_\_\_



**BIDDER'S PROPOSAL - BID SCHEDULE  
PROJECT NO. 807-0048  
MORENO VALLEY COMMUNITY PARK SKATE PARK**

**BASE BID ITEMS AS FOLLOWS:**

| DESCRIPTION OF ITEMS PER PLANS AND SPECIFICATIONS | QTY | UNIT | UNIT COST | TOTAL COST |
|---|-----|------|-----------|------------|
|---|-----|------|-----------|------------|

**PLANTING**

|    |  |   |    |  |  |
|----|--|---|----|--|--|
| 24 | SOIL PREPARATION                         | 1 | LS |  |  |
| 25 | FINE GRADE                               | 1 | LS |  |  |
| 26 | WEED ABATEMENT                           | 1 | LS |  |  |
| 27 | TURF SOD                                 | 1 | LS |  |  |
| 28 | SOD REPAIR ALLOWANCE DUE TO CONSTRUCTION | 1 | LS |  |  |
| 29 | 90 DAY MAINTENANCE                       | 1 | LS |  |  |

**PLANTING TOTAL** \_\_\_\_\_

**IRRIGATION**

|    |  |   |    |  |  |
|----|--|---|----|--|--|
| 30 | AUTOMATIC IRRIGATION SYSTEM MODIFICATION | 1 | LS |  |  |
|----|--|---|----|--|--|

**IRRIGATION TOTAL** \_\_\_\_\_

**LIGHTING AND ELECTRICAL**

|    |                               |   |    |  |  |
|----|-------------------------------|---|----|--|--|
| 31 | POLE AND FIXTURE INSTALLATION | 1 | LS |  |  |
| 32 | SITE ELECTRICAL WORK          | 1 | LS |  |  |

**LIGHTING AND ELECTRICAL TOTAL** \_\_\_\_\_

|   |  |
|---|--|
| <b>TOTAL BASE BID PRICE</b> (BASED ON ESTIMATED QUANTITIES OF ITEMS 1 THROUGH 32) |  |
|---|--|

Note: Estimated quantities are for the purpose of Bid comparison only; payments will be made on the basis of actual measurement of Work completed, except for lump sum (LS) and final pay (F) quantities. (S) denotes a specialty item. The Bid Price shall include, but not be limited to, sales tax and all other applicable taxes and fees.

Attachment: REQUEST FOR BID 2019-034 - MVCP SKATE PARK (3355 : APPROVE AND EXECUTE AGREEMENT WITH MICON CONSTRUCTION

BOND NO. \_\_\_\_\_

**BID BOND**

**COMMUNITY PARK SKATE PARK  
PROJECT NO. 807-0048**

KNOW ALL MEN OR WOMEN BY THESE PRESENTS:

That \_\_\_\_\_, as Principal, hereinafter referred to as

"Contractor," and \_\_\_\_\_, a duly authorized corporate as Surety, are held and firmly bound unto the City of Moreno Valley in the penal sum of TEN PERCENT (10%) OF THE TOTAL AMOUNT OF THE BID (Total Base Bid Price plus Alternate Bid Price, if any) of the Contractor above named, submitted by said Contractor to the City of Moreno Valley for the Work for said Project entitled above, for the payment of which sum in lawful money of the United States, well and truly to be made, to the City of Moreno Valley to which said Bid was submitted, we bind ourselves, our heirs, executors, administrators and successors, jointly and severally liable (CCP 995.320 (a)(1), PCC 20171), firmly by these presents. In no case shall the liability of the Surety hereunder exceed the amount of:

\_\_\_\_\_.

THE CONDITION OF THIS OBLIGATION IS SUCH:

That whereas the Contractor has submitted the above-mentioned Bid to the City of Moreno Valley as aforesaid for the Work for said Project entitled above.

NOW, THEREFORE, if the aforesaid Contractor is awarded the Contract and, within the time and manner required under the Bid Documents, after the prescribed forms are presented to him or her for signature, enters into a written Agreement in the prescribed form and in accordance with the Bid Documents, and files two bonds with the City of Moreno Valley, one to guarantee Faithful Performance and the other to guarantee payment for labor and materials, in accordance with said Bidding Documents, and as required by law, and files the required insurance certificate(s) in accordance with said Bidding Documents, then this obligation shall be null and void; otherwise, it shall be and remain in full force and effect until execution of the Agreement or forfeiture pursuant to the Provisions of Sections 20172 and 20174 of the Public Contract Code. The Surety hereby waives notice of an agreement between the City and Contractor to extend the time in which the City may accept the Bid.

In the event suit is brought upon this bond by the City and judgment is recovered, the Surety shall pay all costs incurred by the City in such suit, including a reasonable attorney fee to be fixed by the court.

**(SIGNATURE PAGE FOLLOWS)**

Attachment: REQUEST FOR BID 2019-034 - MVCP SKATE PARK (3355 : APPROVE AND EXECUTE AGREEMENT WITH MICON CONSTRUCTION

IN WITNESS WHEREOF, we have hereunto set our hands and seals on this \_\_\_\_ day of \_\_\_\_\_, 20\_\_\_\_.

BIDDER (Principal)

CORPORATE SURETY

Name: \_\_\_\_\_

Company Name: \_\_\_\_\_

Address: \_\_\_\_\_

Address: \_\_\_\_\_

\_\_\_\_\_

\_\_\_\_\_

Telephone No.: \_\_\_\_\_

Telephone No.: \_\_\_\_\_

Print Name: \_\_\_\_\_

Print Name: \_\_\_\_\_

Title: \_\_\_\_\_

Signature: \_\_\_\_\_

Signature: \_\_\_\_\_  
(Attorney-In-Fact)

Date: \_\_\_\_\_

Date: \_\_\_\_\_

**SIGNING INSTRUCTIONS**

- The bond shall be executed by a California admitted surety insurer (CCP 995.311).
- The bond shall include an attached Notary Certificate for the Attorney-in-Fact.
- The bond shall include an attached Notary Certificate for the Bidder.
- The bond shall include an attached original Power of Attorney only authorizing the Attorney-in-Fact to act for the Surety.
- The bond shall include the address at which the Principal (Bidder) and Surety may be served with notices, papers and other documents.

If any of the above items are omitted, the Bid will be considered non-responsive and will be rejected.

Attachment: REQUEST FOR BID 2019-034 - MVCP SKATE PARK (3355 : APPROVE AND EXECUTE AGREEMENT WITH MICON CONSTRUCTION

# CALIFORNIA ALL-PURPOSE CERTIFICATE OF ACKNOWLEDGMENT

State of California

County of \_\_\_\_\_

## SAMPLE

On \_\_\_\_\_ before me, \_\_\_\_\_,

(Here insert name and title of the officer)

personally appeared

who proved to me on the basis of satisfactory evidence to be the person(s) whose name(s) is/are subscribed to the within instrument and acknowledgement to me that he/she they executed the same in his/her/their authorized capacity(ies), and that by his/her/their signature(s) on the instrument the person(s), or the entity upon behalf of which the person(s) acted, executed the instrument.

I certify under PENALTY OF PERJURY under the laws of the State of California that the foregoing paragraph is true and correct.

WITNESS my hand and official seal.

(Notary Seal)

\_\_\_\_\_  
Signature of Notary Public

### ADDITIONAL OPTIONAL INFORMATION

#### INSTRUCTIONS FOR COMPLETING THIS FORM

*Any acknowledgment completed in California must contain verbiage exactly as appears above in the notary section or a separate acknowledgment form must be properly completed and attached to that document. The only exception is if a document is recorded outside of California. In such instances, any alternative acknowledgment verbiage as may be printed on such a document so long as the verbiage does not require the notary to do something that is illegal for a notary in California (i.e. certifying the authorized capacity of the signer). Please check the document carefully for proper notarial wording and attach this form if required.*

#### DESCRIPTION OF THE ATTACHED DOCUMENT

BIDDER'S BOND SIGNATURE PAGE

(Title or description of attached document)

\_\_\_\_\_  
(Title or description of attached document continued)

#### CAPACITY CLAIMED BY THE SIGNER

- Individual(s)
- Corporate Officer

\_\_\_\_\_  
(Title)

- Partner (s)
- Attorney-in-Fact
- Other

\_\_\_\_\_  
-

- State and County information must be the State and County where the document signer(s) personally appeared before the notary public for acknowledgment.
- Date of notarization must be the date that the signer(s) personally appeared which must also be the same date the acknowledgment is completed.
- The notary public must print his or her name as it appears within his or her commission followed by a comma and then your title (notary public).
- Print the name(s) of document signer(s) who personally appear at the time of notarization.
- Indicate the correct singular or plural forms by crossing off incorrect forms (i.e. ~~he~~/she/~~they~~, is/~~are~~) or circling the correct forms. Failure to correctly indicate this information may lead to rejection of document recording.
- The notary seal impression must be clear and photographically reproducible. Impression must not cover text or lines. If seal impression smudges, re-seal if a sufficient area permits, otherwise complete a different acknowledgment form.
- Signature of the notary public must match the signature on file with the office of the county clerk.
  - ❖ Additional information is not required but could help to ensure this acknowledgment is not misused or attached to a different document.
  - ❖ Indicate title or type of attached document, number of pages and date.
  - ❖ Indicate the capacity claimed by the signer. If the claimed capacity is a corporate officer, indicate the title (i.e. CEO, CFO, Secretary).
- Securely attach this document to the signed document.

Attachment: REQUEST FOR BID 2019-034 - MVCP SKATE PARK (3355 : APPROVE AND EXECUTE AGREEMENT WITH MICON CONSTRUCTION

BIDDER'S PROPOSAL – CONTRACTOR'S STATEMENT**SUBMIT WITH ELECTRONIC BID SUBMISSION**  
**COMMUNITY PARK SKATE PARK**

NAME OF BIDDER: \_\_\_\_\_

**GENERAL**

To be considered, all information requested must be submitted on this Contractor's Statement form or on sheets which clearly identify the paragraph number and subparts being responded to. Additionally, to the extent this form does not provide sufficient space to fully respond, contractors should attach additional sheets as necessary referencing the appropriate paragraph number and subparagraph. The Contractor's Statement shall not be public records. The Contractor's Statement will need to be scanned and uploaded with bid submission onto the Planet Bids website.

All questions must be answered and the data must be clear and complete. Line items that do not require a response shall be noted with a "N/A" referencing items that are not applicable.

1. Contractor is able to obtain insurance for the Bid Package with the minimum scope and limits specified in **Paragraph 7** of the Agreement.  
 Yes       No
  
2. Contractor has current workers' compensation insurance policy as required by the Labor Code or is legally self-insured pursuant to Labor Code section 3700 *et seq.*  
 Yes       No  
 Contractor is exempt from this requirement, because it has no employees
  
3. Have you been in business for a minimum of **three (3) years** under the contractor's license used for the Bid you are submitting?  
 Yes       No
  
4. Have you satisfactorily completed: **1)** at least **one (1)** prevailing wage public contract in California; **and 2)** at least **one (1)** contract comparable in scope and scale to the Project for which the Bid is submitted, completed within **five (5)** years prior to the Bid Deadline and with the dollar value of Bidder's portion of each such project in excess of the Base Bid Price submitted for this Project?  
 Yes       No

5. Has your contractor's license been revoked at any time in the last five years?  
 Yes  No

6. Has a surety firm completed a contract on your behalf, or paid for completion because your firm was default terminated by the project owner within the last five (5) years?  
 Yes  No

7. Complete the following information for each project for which a bonding company has had to complete any part of your work during the last five (5) years. (Attach additional sheets as necessary.)

- (a) Project: \_\_\_\_\_
- (b) Amount Bonded: \_\_\_\_\_
- (c) Bonding Company: \_\_\_\_\_
- (d) Percent of Project Completed: \_\_\_\_\_
- (e) Name of Contractor Completing Project: \_\_\_\_\_

8. At the time of submitting this form, is your firm ineligible to bid on or be awarded a public works contract, or perform as a subcontractor on a public works contract, pursuant to Labor Code section 1777.1, Labor Code section 1777.7?  
 Yes  No

If the answer is "Yes," state the beginning and ending dates of the period of debarment:  
\_\_\_\_\_

9. At the time of submitting this form, is your firm debarred or otherwise ineligible to bid on or be awarded contracts from the City of Moreno Valley, the federal government, or any other public agencies in California?  
 Yes  No

If the answer is "Yes," state the beginning and ending dates of the period of debarment:  
\_\_\_\_\_

10. At any time during the last five years, has your firm, or any of its owners or officers, been convicted of a crime involving the awarding of a contract of a government construction project, or the bidding or performance of a government contract?  
 Yes  No

11. Has your firm, or any of its owners or officers, been issued, within a two (2) year period, three (3) final administrative or criminal citations for violations of the City of Moreno Valley Municipal Code?  
 Yes  No

Attachment: REQUEST FOR BID 2019-034 - MVCP SKATE PARK (3355 : APPROVE AND EXECUTE AGREEMENT WITH MICON CONSTRUCTION

12. How many years has your organization been in business? \_\_\_\_\_  
What year was your organization established? \_\_\_\_\_

13. How many years has your organization been in business under its present business name?  
\_\_\_\_\_

Under what other or former names has your organization operated?  
\_\_\_\_\_

14. Identify parent company if applicable: \_\_\_\_\_

15. Have you ever been licensed under a different name or different license number?

Yes  No

If the answer is yes, give name and license number: \_\_\_\_\_

Complete the following information for **completed** construction contracts with public agencies, including, but not limited to contracts with the City of Moreno Valley. (List three projects maximum. Attach additional sheets as necessary, but answer all questions identified below for each project.)

**Project #1**

(a) Name of Agency's Project Manager: \_\_\_\_\_

(b) Name of Project: \_\_\_\_\_

(c) Name of Agency: \_\_\_\_\_

(d) Project Address: \_\_\_\_\_

City: \_\_\_\_\_ State: \_\_\_\_\_ Zip: \_\_\_\_\_

(e) Agency's Contact Phone: (\_\_\_\_) \_\_\_\_\_

(f) Type of Facility: \_\_\_\_\_

(g) Contract Type: \_\_\_\_\_

(h) Contract Amount: \_\_\_\_\_

(i) Percent Change Orders to Base Contract: \_\_\_\_\_

(j) Percent Complete: \_\_\_\_\_

- (k) Percent Work Performed With Own Forces: \_\_\_\_\_
- (l) Scheduled Completion Date: \_\_\_\_\_
- (m) Actual Completion Date: \_\_\_\_\_
- (n) Explain any differences between scheduled and actual completion dates:

\_\_\_\_\_

\_\_\_\_\_

- (o) Explain any differences between the original contract price and the actual cost to complete:

\_\_\_\_\_

\_\_\_\_\_

**Project #2**

- (a) Name of Agency's Project Manager: \_\_\_\_\_
- (b) Name of Project: \_\_\_\_\_
- (c) Name of Agency: \_\_\_\_\_
- (d) Project Address: \_\_\_\_\_

City: \_\_\_\_\_ State: \_\_\_\_\_ Zip: \_\_\_\_\_

- (e) Agency's Contact Phone: (\_\_\_\_) \_\_\_\_\_
- (f) Type of Facility: \_\_\_\_\_
- (g) Contract Type: \_\_\_\_\_
- (h) Contract Amount: \_\_\_\_\_
- (i) Percent Change Orders to Base Contract: \_\_\_\_\_
- (j) Percent Complete: \_\_\_\_\_
- (k) Percent Work Performed With Own Forces: \_\_\_\_\_
- (l) Scheduled Completion Date: \_\_\_\_\_
- (m) Actual Completion Date: \_\_\_\_\_
- (n) Explain any differences between scheduled and actual completion dates: \_\_\_\_\_

\_\_\_\_\_

\_\_\_\_\_

- (o) Explain any differences between the original contract price and the actual cost to complete:

\_\_\_\_\_

\_\_\_\_\_



**Project #3**

- (a) Name of Agency's Project Manager: \_\_\_\_\_
- (b) Name of Project: \_\_\_\_\_
- (c) Name of Agency: \_\_\_\_\_
- (d) Project Address: \_\_\_\_\_

City: \_\_\_\_\_ State: \_\_\_\_\_ Zip: \_\_\_\_\_

- (e) Agency's Contact Phone: (\_\_\_\_) \_\_\_\_\_
- (f) Type of Facility: \_\_\_\_\_
- (g) Contract Type: \_\_\_\_\_
- (h) Contract Amount: \_\_\_\_\_
- (i) Percent Change Orders to Base Contract: \_\_\_\_\_
- (j) Percent Complete: \_\_\_\_\_
- (k) Percent Work Performed With Own Forces: \_\_\_\_\_
- (l) Scheduled Completion Date: \_\_\_\_\_
- (m) Actual Completion Date: \_\_\_\_\_
- (n) Explain any differences between scheduled and actual completion dates: \_\_\_\_\_

\_\_\_\_\_  
\_\_\_\_\_

- (o) Explain any differences between the original contract price and the actual cost to complete: \_\_\_\_\_
- \_\_\_\_\_  
\_\_\_\_\_

16. List any projects in which your organization has been involved in any claim for delay, extra work or equitable contract adjustment in the last five years in which the amount in controversy exceeded \$25,000. Identify claims by name of project, parties involved, description of claim and ultimate resolution (attach additional sheets as necessary):

- (a) Name of Project: \_\_\_\_\_
  - (b) Project Location: \_\_\_\_\_
  - (c) Date of Claim: \_\_\_\_\_
  - (d) Parties Involved: \_\_\_\_\_
- \_\_\_\_\_

(e) Description of Claim: \_\_\_\_\_  
\_\_\_\_\_  
\_\_\_\_\_

(f) Result: \_\_\_\_\_  
\_\_\_\_\_  
\_\_\_\_\_

17. Has your organization ever been terminated from a project before completion? If so, please provide the following information: (List three projects maximum. Attach additional sheets as necessary.)

**Project #1**

(a) Name of Project: \_\_\_\_\_

(b) Project Location: \_\_\_\_\_

(c) Client Name: \_\_\_\_\_

(d) Client Contact: \_\_\_\_\_

Client Telephone No: \_\_\_\_\_

(e) Architect Name: \_\_\_\_\_

(f) Architect Telephone No: \_\_\_\_\_

(g) Date of Termination: \_\_\_\_\_

(h) Reason for Termination: \_\_\_\_\_  
\_\_\_\_\_  
\_\_\_\_\_

**Project #2**

(a) Name of Project: \_\_\_\_\_

(b) Project Location: \_\_\_\_\_

(c) Client Name: \_\_\_\_\_

(d) Client Contact: \_\_\_\_\_

(e) Client Telephone No: \_\_\_\_\_

(f) Architect Name: \_\_\_\_\_

(g) Architect Telephone No: \_\_\_\_\_

(h) Date of Termination: \_\_\_\_\_

Attachment: REQUEST FOR BID 2019-034 - MVCP SKATE PARK (3355 : APPROVE AND EXECUTE AGREEMENT WITH MICON CONSTRUCTION

(i) Reason for Termination: \_\_\_\_\_  
\_\_\_\_\_  
\_\_\_\_\_

**Project #3**

- (a) Name of Project: \_\_\_\_\_
- (b) Project Location: \_\_\_\_\_
- (c) Client Name: \_\_\_\_\_
- (d) Client Contact: \_\_\_\_\_
- (e) Client Telephone No: \_\_\_\_\_
- (f) Architect Name: \_\_\_\_\_
- (g) Architect Telephone No: \_\_\_\_\_
- (h) Date of Termination: \_\_\_\_\_
- (i) Reason for Termination: \_\_\_\_\_  
\_\_\_\_\_  
\_\_\_\_\_

I, the undersigned, certify and declare that I have read all the foregoing answers to the questionnaire and know their contents. The matters stated in the questionnaire answers are true of my own knowledge and belief, except as to those matters stated on information and belief, and as to those matters I believe them to be true. I declare under penalty of perjury under the laws of the State of California that the foregoing is correct.

Company Name: \_\_\_\_\_

Dated: \_\_\_\_\_

Signed: \_\_\_\_\_

Name: \_\_\_\_\_

Title: \_\_\_\_\_

California Public Contract Code § 9204 (full text)

9204. (a) The Legislature finds and declares that it is in the best interests of the state and its citizens to ensure that all construction business performed on a public works project in the state that is complete and not in dispute is paid in full and in a timely manner.

(b) Notwithstanding any other law, including, but not limited to, Article 7.1 (commencing with Section 10240) of Chapter 1 of Part 2, Chapter 10 (commencing with Section 19100) of Part 2, and Article 1.5 (commencing with Section 20104) of Chapter 1 of Part 3, this section shall apply to any claim by a contractor in connection with a public works project.

(c) For purposes of this section:

(1) "Claim" means a separate demand by a contractor sent by registered mail or certified mail with return receipt requested, for one or more of the following:

(A) A time extension, including, without limitation, for relief from damages or penalties for delay assessed by a public entity under a contract for a public works project.

(B) Payment by the public entity of money or damages arising from work done by, or on behalf of, the contractor pursuant to the contract for a public works project and payment for which is not otherwise expressly provided or to which the claimant is not otherwise entitled.

(C) Payment of an amount that is disputed by the public entity.

(2) "Contractor" means any type of contractor within the meaning of Chapter 9 (commencing with Section 7000) of Division 3 of the Business and Professions Code who has entered into a direct contract with a public entity for a public works project.

(3) (A) "Public entity" means, without limitation, except as provided in subparagraph (B), a state agency, department, office, division, bureau, board, or commission, the California State University, the University of California, a city, including a charter city, county, including a charter county, city and county, including a charter city and county, district, special district, public authority, political subdivision, public corporation, or nonprofit transit corporation wholly owned by a public agency and formed to carry out the purposes of the public agency.

(B) "Public entity" shall not include the following:

(i) The Department of Water Resources as to any project under the jurisdiction of that department.

(ii) The Department of Transportation as to any project under the jurisdiction of that department.

(iii) The Department of Parks and Recreation as to any project under the jurisdiction of that department.

(iv) The Department of Corrections and Rehabilitation with respect to any project under its jurisdiction pursuant to Chapter 11 (commencing with Section 7000) of Title 7 of Part 3 of the Penal Code.

(v) The Military Department as to any project under the jurisdiction of that department.

(vi) The Department of General Services as to all other projects.

(vii) The High-Speed Rail Authority.

(4) "Public works project" means the erection, construction, alteration, repair, or improvement of any public structure, building, road, or other public improvement of any kind.

(5) "Subcontractor" means any type of contractor within the meaning of Chapter 9 (commencing with Section 7000) of Division 3 of the Business and Professions Code who either is in direct contract with a contractor or is a lower tier subcontractor.

(d) (1) (A) Upon receipt of a claim pursuant to this section, the public entity to which the claim applies shall conduct a reasonable review of the claim and, within a period not to exceed 45 days, shall provide the claimant a written statement identifying what portion of the claim is disputed and what portion is undisputed. Upon receipt of a claim, a public entity and a contractor may, by mutual agreement, extend the time period provided in this subdivision.

(B) The claimant shall furnish reasonable documentation to support the claim.

(C) If the public entity needs approval from its governing body to provide the claimant a written statement identifying the disputed portion and the undisputed portion of the claim, and the governing body does not meet within the 45 days or within the mutually agreed to extension of time following receipt of a claim sent by registered mail or certified mail, return receipt requested, the public entity shall have up to three days following the next duly publicly noticed meeting of the governing body after the 45-day period, or extension, expires to provide the claimant a written statement identifying the disputed portion and the undisputed portion.

(D) Any payment due on an undisputed portion of the claim shall be processed and made within 60 days after the public entity issues its written statement. If the public entity fails to issue a written statement, paragraph (3) shall apply.

(2) (A) If the claimant disputes the public entity's written response, or if the public entity fails to respond to a claim issued pursuant to this section within the time prescribed, the claimant may demand in writing an informal conference to meet and confer for settlement of the issues in dispute. Upon receipt of a demand in writing sent by registered mail or certified mail, return receipt requested, the public entity shall schedule a meet and confer conference within 30 days for settlement of the dispute.

(B) Within 10 business days following the conclusion of the meet and confer conference, if the claim or any portion of the claim remains in dispute, the public entity shall provide the claimant a written statement identifying the portion of the claim that remains in dispute and the portion that is undisputed. Any payment due

on an undisputed portion of the claim shall be processed and made within 60 days after the public entity issues its written statement. Any disputed portion of the claim, as identified by the contractor in writing, shall be submitted to nonbinding mediation, with the public entity and the claimant sharing the associated costs equally. The public entity and claimant shall mutually agree to a mediator within 10 business days after the disputed portion of the claim has been identified in writing. If the parties cannot agree upon a mediator, each party shall select a mediator and those mediators shall select a qualified neutral third party to mediate with regard to the disputed portion of the claim. Each party shall bear the fees and costs charged by its respective mediator in connection with the selection of the neutral mediator. If mediation is unsuccessful, the parts of the claim remaining in dispute shall be subject to applicable procedures outside this section.

(C) For purposes of this section, mediation includes any nonbinding process, including, but not limited to, neutral evaluation or a dispute review board, in which an independent third party or board assists the parties in dispute resolution through negotiation or by issuance of an evaluation. Any mediation utilized shall conform to the timeframes in this section.

(D) Unless otherwise agreed to by the public entity and the contractor in writing, the mediation conducted pursuant to this section shall excuse any further obligation under Section 20104.4 to mediate after litigation has been commenced.

(E) This section does not preclude a public entity from requiring arbitration of disputes under private arbitration or the Public Works Contract Arbitration Program, if mediation under this section does not resolve the parties' dispute.

(3) Failure by the public entity to respond to a claim from a contractor within the time periods described in this subdivision or to otherwise meet the time requirements of this section shall result in the claim being deemed rejected in its entirety. A claim that is denied by reason of the public entity's failure to have responded to a claim, or its failure to otherwise meet the time requirements of this section, shall not constitute an adverse finding with regard to the merits of the claim or the responsibility or qualifications of the claimant.

(4) Amounts not paid in a timely manner as required by this section shall bear interest at 7 percent per annum.

(5) If a subcontractor or a lower tier subcontractor lacks legal standing to assert a claim against a public entity because privity of contract does not exist, the contractor may present to the public entity a claim on behalf of a subcontractor or lower tier subcontractor. A subcontractor may request in writing, either on his or her own behalf or on behalf of a lower tier subcontractor, that the contractor present a claim for work which was performed by the subcontractor or by a lower tier subcontractor on behalf of the subcontractor. The subcontractor requesting that the claim be presented to the public entity shall furnish reasonable documentation to support the claim. Within 45 days of receipt of this written request, the contractor shall notify the subcontractor in writing as to whether the contractor presented the claim to the public entity and, if the original contractor did not present the claim, provide the subcontractor with a statement of the reasons for not having done so.

(e) The text of this section or a summary of it shall be set forth in the plans or specifications for any public works project that may give rise to a claim under this section.

(f) A waiver of the rights granted by this section is void and contrary to public policy, provided, however, that (1) upon receipt of a claim, the parties may mutually agree to waive, in writing, mediation and proceed directly to the commencement of a civil action or binding arbitration, as applicable; and (2) a public entity may prescribe reasonable change order, claim, and dispute resolution procedures and requirements in addition to the provisions of this section, so long as the contractual provisions do not conflict with or otherwise impair the timeframes and procedures set forth in this section.

(g) This section applies to contracts entered into on or after January 1, 2017.

(h) Nothing in this section shall impose liability upon a public entity that makes loans or grants available through a competitive application process, for the failure of an awardee to meet its contractual obligations.

(i) This section shall remain in effect only until January 1, 2020, and as of that date is repealed, unless a later enacted statute, that is enacted before January 1, 2020, deletes or extends that date.

SEC. 2. The Legislature finds and declares that it is of statewide concern to require a charter city, charter county, or charter city and county to follow a prescribed claims resolution process to ensure there are uniform and equitable procurement practices.

SEC. 3. If the Commission on State Mandates determines that this act contains costs mandated by the state, reimbursement to local agencies and school districts for those costs shall be made pursuant to Part 7 (commencing with Section 17500) of Division 4 of Title 2 of the Government Code.

**AGENCY SPECIAL PROVISIONS**

**PART 1**

**GENERAL PROVISIONS 0701**

Attachment: SPECIAL PROVISIONS - MVCP SKATE PARK (3355 : APPROVE AND EXECUTE AGREEMENT WITH MICON CONSTRUCTION FOR



# SECTION 1 – TERMS, DEFINITIONS, ABBREVIATIONS, UNITS OF MEASURE, AND SYMBOLS

## 1-1.1 GENERAL

The Work shall be performed in accordance with the Special Provisions which amend, modify, and/or supplement Sections 1 through 800 of the latest edition of the “Greenbook,” Standard Specifications for Public Works Construction (including all supplement amendments), in effect and published at the Bid Deadline.

## 1-2 TERMS AND DEFINITIONS

Add the following:

| <u>WORD or WORDS</u>               | <u>DEFINITION</u>  |
|------------------------------------|--|
| Admitted                           | Entitled to transact insurance business in California (CCP995.120).  |
| Agency                             | The City of Moreno Valley and the City of Moreno Valley Community Services District (CSD).   |
| Alternate Bid, Alternate Bid Price | The amount stated in the Bid for which the Bidder offers to perform the Work described in the Bidding Documents as Alternate Work, to be added or deducted from the <b>Base Bid</b> , which shall be the Contractor’s responsibility if the Agency accepts the Alternate Bid Item. |
| Applicable Law                     | All state, federal, and local laws, statutes, ordinances, codes, rules, and regulations governing the Work.  |
| <b>Base Bid, Base Bid Price</b>    | The amount stated in the Bid for which the Bidder offers to perform the Work described in the Bidding Documents as the <b>base</b> Contract Work (i.e. not including Alternate Bid Items).   |
| Bidding Documents                  | The proposed Contract Documents and Bidding Requirements prepared by the Agency for bidding.   |
| Bidding Requirements               | The Notice Inviting Bids, Instructions to Bidders, Bidder’s Proposal, Subcontractor Listing, Bidder’s Bond, and Contractor’s Statement.  |
| Bid Item                           | An item of Work listed on the Bid Schedule.  |
| Board                              | The City Council of the City of Moreno Valley, which is the awarding authority of the City.  |

WORD or WORDS

DEFINITION

CA Building Code

The latest edition adopted by the City of Moreno Valley of the CALIFORNIA BUILDING CODE, as published by the International Conference of Building Officials, 5360 South Workman Mill Road, Whittier, California 90601. Builders Books, Inc., 7943 Canoga Avenue, Canoga Park, California 91304, Telephone 1-800-273-7375. The Agency does not endorse any bookstore, but has provided a source where the information may be obtained.

CA Electrical Code

The latest edition adopted by the City of Moreno Valley of the CALIFORNIA ELECTRICAL CODE BASED ON THE LATEST EDITION OF THE NATIONAL ELECTRICAL CODE as developed by the National Fire Protection Association, 1 Batterymarch Park, P.O. Box 9101, Quincy, MA 02269-9101.

CA Fire Code

The latest edition adopted by the City of Moreno Valley of the CALIFORNIA FIRE CODE, as published by the International Conference of Building Officials, 5360 South Workman Mill Road, Whittier, California 90601, and Western Fire Chiefs Association, Palm Brook Corporate Center, 3602 Inland Empire Boulevard, Suite B-205, Ontario, California 90601.

CA Mechanical Code

The latest edition adopted by the City of Moreno Valley of the CALIFORNIA MECHANICAL CODE, as published by the International Association of Plumbing and Mechanical Officials.

CA Plumbing Code

The latest edition adopted by the City of Moreno Valley of the CALIFORNIA PLUMBING CODE, as published by the International Association of Plumbing and Mechanical Officials.

Calendar Day

24 hours beginning at 12 midnight and ending at 11:59 p.m.

Change Order

A written instrument prepared by the Agency and signed by the Agency and the Contractor, stating their agreement upon all of the following: (1) the scope of the change in the Work; (2) the amount of the adjustment, if any, in the Contract Price; and (3) the extent of the adjustment, if any, in the Contract Time. See Subsection 3-2.1.1 of the Special Provisions.

Change Order Proposal Request

A request issued by the Agency to the Contractor that describes a proposed change to the Work and requests that the Contractor submit an itemized Change Order Proposal to the Agency. See Subsection 3-2.1 of the Special Provisions.

City

The City of Moreno Valley.

| <u>WORD or WORDS</u>        | <u>DEFINITION</u>   |
|-----------------------------|---|
| City Council                | The City Council of the City of Moreno Valley.  |
| Special Provisions          | Provisions of the Agency that amend, modify, and/or supplement Sections 1 through 800 of the latest edition of the "Greenbook," Standard Specifications for Public Works Construction (including all supplement amendments), in effect and published at the Bid Deadline.   |
| Construction                | A written order prepared and signed by the Agency, directing a change in the Work prior to the Contractor's agreement on adjustment, if any, in the Contract Price or Contract Time, or both. See Subsection 3-2.1.2 of the Special Provisions.   |
| Change Directive            |   |
| Contract Documents          | The Contract Documents are enumerated in the Agreement.   |
| Contract Time               | The number of Working Days stated in the Agreement for the completion of the Work.  |
| Contractor's Representative | See Subsection 7-6 of the Special Provisions.   |
| CSD                         | Community Services District of the City of Moreno Valley  |
| Detour                      | A temporary route for traffic (vehicular or pedestrian) around a closed portion of a road or travelway.   |
| Director                    | Director of Parks and Community Services Department   |
| District                    | The Riverside County Flood Control & Water Conservation District (RCFC&WCD)   |
| Drawings or Plans           | The part of the Contract Documents which show the characteristics and scope of the Work to be performed, and which have been prepared or approved by the Engineer.  |
| Engineer                    | The Director of Parks and Community Services or person(s) designated by the Director acting either directly or through authorized agents.   |
| Estimated Quantities        | The quantities Work anticipated to be performed, as set forth in the Bid Schedule, designated as units or a lump sum.   |
| Excavation                  | Any operation in which earth, rock, or other material in the ground is moved, removed, or otherwise displaced by means of tools, equipment, or explosives in any of the following ways: grading, trenching, digging, ditching, drilling, augering, tunneling, scraping, cable or pipe plowing and driving, or any other way (CGC 4216). |

| <u>WORD or WORDS</u>                       | <u>DEFINITION</u>  |
|--|--|
| Field Order                                | A written order effecting a change in the Work not involving an adjustment in the Contract Price or an extension of the Contract Time, issued by the Engineer to the Contractor during construction.   |
| Final Acceptance                           | Final Acceptance (Final Acceptance of the Work) occurs when the Engineer determines that Final Completion (as defined in Subsection 9-3.1 of the Special Provisions) of the Work has been achieved and a Notice of Completion has been recorded with the County of Riverside by the Agency. The date of Final Acceptance is the date the Notice of Completion is recorded by the County of Riverside Recorder.   |
| Final Completion                           | See Subsection 9-3.1 of the Special Provisions for the steps (1 and 2) necessary to achieve Final Completion.  |
| Furlough Day                               | A day on which the Agency is closed for business for budget reasons. A Furlough Day may be a Working Day.  |
| Geotechnical and/or Soils Engineer         | The private consulting geotechnical engineer retained to perform soils material testing.   |
| Hazardous Material                         | <p>(1) A substance or combination of substances, which because of its quantity, concentration, or physical, chemical or infectious characteristics, may either:</p> <p style="padding-left: 40px;">(a) Cause, or significantly contribute to an increase in mortality or an increase in serious irreversible or incapacitating reversible illness; or</p> <p style="padding-left: 40px;">(b) Pose a substantial present or potential hazard to human health or environment when improperly treated, stored, transported or disposed of or otherwise managed.</p> <p>(2) Unless expressly provided otherwise, the term "hazardous material" shall be understood to also include extremely hazardous material.</p> |
| Inspector                                  | The representative of the Engineer who is assigned to inspect conformance of the work to the Plans and Specifications.   |
| Laboratory                                 | The designated laboratory authorized by the Agency to test materials and/or Work.  |
| Labor Surcharge and Equipment Rental Rates | The latest edition in effect on the date the Work is performed. Published by the California Department of Transportation, Caltrans Publications, 1900 Royal Oaks Drive, Sacramento, California 95815.  |

| <u>WORD or WORDS</u>  | <u>DEFINITION</u>  |
|---|--|
| Major Contract Bid Item   | A Bid Item for which the Total Price is 10% or more of the Contract Price.   |
| Manufacturer  | A person, firm, or corporation that fabricates, processes, or creates materials or equipment to be incorporated into the Project from raw materials or component parts.  |
| Minor Contract Bid Item   | A Bid Item for which the Total Price is less than 10% of the Contract Price.   |
| Notice of Completion  | A notice executed by the Engineer and recorded with the County of Riverside Recorder that provides formal notice of the completion of Work and Final Acceptance by the Agency. The Notice of Completion contains the name and address of the Agency, name and address of the Contractor, description of the site sufficient for identification, including the street address of the site, if any, and date of Final Completion. The date of Final Acceptance is the date the Notice of Completion is recorded by the County of Riverside Recorder. |
| Notice to Proceed or Notice to Proceed with Construction                            | A written notice issued by the Agency to the Contractor that authorizes the Contractor to perform the Work.  |
| Notice to Proceed to Fulfill Preconstruction Requirements and/or Order of Materials | A written notice issued by the Agency to the Contractor that authorizes the Contractor to proceed with preconstruction requirements and the acquisition or purchase of materials that are to be incorporated into the Work and establishes the date of commencement of the Contract Time.  |
| Owner   | City of Moreno Valley unless otherwise specified.  |
| Private Architect or Engineer   | (If applicable) The private professional architect or consulting engineer who has prepared and signed the Plans.   |
| Project   | The total construction of which the Work performed under the Contract Documents may be the whole or a part and which may include construction by other contractors and the Agency's own forces.  |
| Plans   | The project drawings and details.  |
| Project Manager   | Parks Projects Coordinator or other assignee.  |
| Punch List  | A list of items of Work to be completed or corrected by the Contractor in order to complete the Work as specified in the Contract Documents.   |

| <u>WORD or WORDS</u>    | <u>DEFINITION</u>   |
|-------------------------|---|
| Registered Bidder       | A Bidder that registers with the Agency by providing its street address, e-mail, phone, and fax to the Agency at the time of pick-up of or request for Bidding Documents.   |
| Reference Documents     | Drawings and documents showing existing site conditions or as-built improvements and made available to Bidders for general background information about the Project. No guarantee is made that existing improvements or site conditions are accurately shown or described on the Reference Documents.   |
| Reference Specification | Any specifications referred to in the Bidding Documents other than Standard Specifications and Special Provisions, including, but not limited to bulletins, standards, rules, methods of analysis or tests, codes, State Standard Specifications, and specifications of other agencies, engineering societies, or industrial associations. These refer to the latest edition, including amendments, in effect and published at the Bid Deadline, unless otherwise specifically referred to by edition, volume, or date. |
| Shop Drawings           | All drawings, diagrams, illustrations, brochures, schedules and other data which are prepared by the Contractor, a subcontractor, manufacturer, supplier, or distributor, which illustrate how specific portions of the Work shall be fabricated or installed.  |
| Specifications          | Standard Specifications, Reference Specifications, Special Provisions, and specifications in Addenda and Contract Change Orders. These refer to the latest edition, including amendments, in effect and published at the Bid Deadline unless otherwise specifically referred to by edition, volume, or date.  |
| Standard Plans          | Standard detail drawings and/or instructions of the Engineering Division of the Public Works Department of the City of Moreno Valley. Also referred to as Standard Drawings.  |
| Standard Specifications | The latest edition of the "Greenbook," <u>Standard Specifications for Public Works Construction</u> , including all <u>Supplemental Amendments</u> , in effect and published at the Bid Deadline, otherwise specifically referred to by edition, volume, or date, prepared by Public Works Standards, Inc., as published by Building News, Inc., 990 Park Center Drive, Suite E, Vista, California 92801. Telephone No. 760.734.1113.   |
| State                   | The State of California   |

WORD or WORDS

DEFINITION

|                               |  |
|-------------------------------|--|
| State Standard Plans          | The latest edition of the Standard Plans of the State of California, Department of Transportation, including amendments, in effect and published at the Bid Deadline, unless otherwise specifically referred to by edition, volume, or date.   |
| State Standard Specifications | The latest edition of the Standard Specifications of the State of California, Department of Transportation, in effect and published at the Bid Deadline, unless otherwise specifically referred to by edition, volume, or date.  |
| Supplier                      | Any person or organization who supplies materials or equipment for the Work, including that fabricated to a special design, but who does not perform labor at the site.  |
| Technical Provisions          | Part of the Special Provisions consisting of a written description of a technical nature of materials, equipment, construction system, standards, and workmanship, which amend, modify, or supplement Sections 1 through 800 of the latest edition of the "Greenbook," Standard Specifications for Public Works Construction (including all supplement amendments), in effect and published at the Bid Deadline, and other agency or utility specifications. |
| Transportation Division       | A division within the City of Moreno Valley Department of Public Works that is assigned traffic-related matters.   |
| Traffic Engineer              | The representative of the City Engineer who is assigned traffic-related matters.   |
| Work                          | The construction and services required by the Contract Documents, whether completed or partially completed, and includes all other labor, materials, equipment, services provided or to be provided by the Contractor to fulfill the Contractor's obligations.   |
| Work Directive                | A unilateral written order issued by the Agency directing the Contractor to continue performance of the Work or a disputed item of Work pending resolution of a claim or dispute concerning the scope of Work.   |
| Working Day                   | See Subsection 6-7.2 of the Special Provisions.  |

WORD or WORDS

DEFINITION

Written Notice

A notice in writing required under the Contract Documents. Written Notice is deemed delivered and the service thereof completed, when: (1) posted by certified or registered U.S. Mail, return receipt requested, to the appropriate party at its last given address, or (2) delivered in person to said party or its authorized representative at the worksite.

**1-3**

**ABBREVIATIONS**

**1-3.2**

**Common Usage**

Add the following to Subsection 1-3.2:

Abbreviation

Word or Words

|          |   |
|----------|---|
| ADA      | Americans with Disabilities Act   |
| AWG      | American Wire Gage  |
| B&P      | Business and Professions Code   |
| CA       | California Administration Code  |
| CA MUTCD | California Manual on Uniform Traffic Control Devices  |
| CBC      | California Building Code as amended by Title 8 of the City's Municipal Code   |
| CC       | Civil Code Section No.  |
| CGC      | California Government Code  |
| CCP      | California Code of Civil Procedure Section No.  |
| CVC      | California Vehicle Code   |
| DBE      | Disadvantaged Business Enterprise   |
| EDC      | Educational Code Section No.  |
| IC       | California Insurance Code Section No.   |
| LC       | Labor Code Section No.  |
| MOU      | Memorandum of Understanding – Riverside County Transportation Department and Riverside County Flood Control and Water Conservation District for Design, Construction, Inspection and Maintenance of Flood Control Drainage Facilities (June 2008) |
| NEC      | National Electrical Code  |
| PCC      | Public Contract Code  |
| PS & E   | Plans Specifications and Estimates  |
| RFI      | Request for Information   |

**1-3.3 Institutions**

Add the following to Subsection 1-3.3:

Abbreviation

Word or Words

|      |  |
|------|--|
| AAN  | American Association of Nurserymen         |
| ACI  | American Concrete Institute                |
| AGA  | American Gas Association                   |
| AI   | The Asphalt Institute                      |
| AIA  | American Institute of Architects           |
| AIEE | American Institute of Electrical Engineers |



|               |  |
|---------------|--|
| AISI          | American Iron & Steel Institute  |
| ANSI          | United States of America Standards Institute                               |
| APHA          | American Public Health Association   |
| APWA          | American Public Works Association  |
| ASA           | American Standards Association (now ANSI)                                  |
| ASCE          | American Society of Civil Engineers  |
| ASHRAE        | American Society of Heating, Refrigerating, and Air Conditioning Engineers |
| ASME          | American Society of Mechanical Engineers                                   |
| CRSI          | Concrete Reinforcing Steel Institute                                       |
| CSD           | Community Services District of the City of Moreno Valley                   |
| EIA           | Electronic Industries Association  |
| EMWD          | Eastern Municipal Water District   |
| IEEE          | Institute of Electrical and Electronics Engineers                          |
| MVHA          | Moreno Valley Housing Authority  |
| NBFU          | National Board of Fire Underwriters  |
| OSA           | Office of State Architect  |
| PCA           | Portland Cement Association  |
| RCFC & WCD    | Riverside County Flood Control and Water Conservation District             |
| RCTC          | Riverside County Transportation Commission                                 |
| RTA           | Riverside Transportation Authority   |
| SSPC          | Steel Structures Painting Council  |
| USASI or USAS | United States of America Standards Institute (Now ANSI)                    |
| WMWD          | Western Municipal Water District   |
| WRCOG         | Western Riverside Council of Governments                                   |

**1-4.2 Units of Measure and Their Abbreviations**

*Add the following to Subsection 1-4.2:*

|              |           |
|--------------|-----------|
| 1 Acre       | 43,560 sf |
| Cubic Yards  | CY        |
| Each         | EA        |
| Feet         | FT        |
| Linear Feet  | LF        |
| Lump Sum     | LS        |
| Square Feet  | SF        |
| Square Yards | SY        |
| Ton          | TN        |

## SECTION 2 – SCOPE AND CONTROL OF WORK

### 2-1 AWARD AND EXECUTION OF CONTRACT

*Delete Subsection 2-1 in its entirety. See the Instructions to Bidders.*

### 2-2 ASSIGNMENT

**2-2.1 Contractor Indebtedness.** Indebtedness incurred by or on behalf of the Contractor for any reason in connection with the Work must be paid by the Contractor. The City, the Moreno Valley Housing Authority (MVHA), and the Moreno Valley Community Services District (CSD), have no obligation for any indebtedness or claim other than payments under terms of the Contract, and the Contractor shall not represent that it has any authority to create such an obligation on behalf of the City of Moreno Valley, the MVHA, or the CSD. The Contractor shall indemnify and hold harmless the City of Moreno Valley, the MVHA, and the CSD, its officers, employees and agents from any loss, demand, damages, claims or actions arising from or in connection with said indebtedness.

### 2-3 SUBCONTRACTS

#### 2-3.1 General

*Add the following at the end of Subsection 2-3.1:*

Pursuant to Labor Code Section 1777.1, the Labor Commissioner publishes and distributes a list of contractors ineligible to perform work as a subcontractor on a public works project. This list of debarred contractors is available from the Department of Industrial Relations website at [http://www.dir.ca.gov/dir/Labor\\_law/DLSE/Debar.html](http://www.dir.ca.gov/dir/Labor_law/DLSE/Debar.html).

All subcontracts shall include a provision that requires each subcontractor, to the extent of the Work to be performed by each subcontractor, to be bound to the Contractor by the terms of the Contract Documents, and to assume toward the Contractor all of the obligations and responsibilities that the Contractor assumes toward the Agency. Each subcontract agreement shall preserve and protect the rights of the Agency under the Contract Documents with respect to the Work to be performed by each subcontractor so that subcontracting thereof will not prejudice such rights, and shall allow to each subcontractor, unless specifically provided otherwise in the subcontract agreement, the benefit of all rights, remedies and redress against the Contractor that the Contractor, by the Contract Documents, has against the Agency. Where appropriate, the Contractor shall require each subcontractor to enter into similar agreements with sub-subcontractors. The Contractor shall make available to each proposed subcontractor, prior to the execution of the subcontract agreement, copies of the Contract Documents to which the subcontractor shall be bound by this subsection of the Standard Specifications and the Agency's Special Provisions. If any provision of any subcontract is inconsistent with any provision of the Contract Documents or the intent of the Contract Documents, then the Contract Documents shall control.

Subcontracts shall also contain certification by the subcontractors that said subcontractor is experienced in and qualified to do, and knowledgeable about, the subcontracted Work. Copies of subcontracts shall be provided to the Engineer upon request.

**2-3.2 Self Performance**

*Add the following at the end of Subsection 2-3.2:*

Any Bid that does not indicate that Work valued at least fifty-one percent (51%) of the Contract Price (except Specialty Items) will be performed by the Bidder's own forces, will be considered non-responsive and will be rejected with no further consideration. If, after execution of the Agreement, the 's discovers the Contractor is performing Work valued at less than fifty percent (51%) of the Contract Price (except Specialty Items), the Contractor will be notified that it is in breach of the Contract. The Contractor's obligation to self-perform at least fifty percent (51%) of the Contract Price (except Specialty Items) is not subject to Change Orders that increase the value of subcontracted items of Work.

**2-3.3 Status of Subcontractors**

*Add the following at the end of Subsection 2-3.3:*

The Contractor shall be as fully responsible to the Agency for the acts and omissions of subcontractors and of persons employed by them as the Contractor is for the acts and omissions of persons directly employed by the Contractor. The Contractor shall be responsible for the coordination of the trades, subcontractors, and material suppliers engaged upon their Work. Neither the Agency nor any representative of the Agency will undertake to settle any difference between the Contractor and subcontractors or between subcontractors.

**2-4 CONTRACT BONDS**

*Delete Subsection 2-4 in its entirety. See Paragraph HHH of the Agreement.*

**2-5 PLANS AND SPECIFICATIONS****2-5.1 General**

*Add the following at the end of Subsection 2-5.1:*

**2-5.1.1 Standard Specifications**

Except as otherwise specified on the Plans or in these Special Provisions, all Work shall be in accordance with the Standard Specifications. Any reference to "Section" or "Subsection" in these Special Provisions shall refer to said Standard Specifications unless noted otherwise.

**2-5.3 Submittals****2-5.3.1 General**

*Add the following at the end of Subsection 2-5.3.1:*

As specified in Section 5 of the Agreement, the Contractor shall, at its own expense, transmit to the Engineer for review and acceptance, working drawings, shop drawings, supporting information, and/or other available instructive and descriptive information from the manufacturer, when and as required by the Plans or these Special Provisions or requested by the Engineer. Shop drawings will not be required for standard items in common use for which adequate manufacturers' literature is available unless otherwise required by the Engineer.

The Contractor shall consecutively number, thoroughly check, approve and sign each submittal and transmit the submittals to the Engineer for review. In the event that certain submittals are submitted without the Contractor's approval signature or are unacceptable to the

Agency, they shall be rejected by the Engineer. The Contractor shall thereafter correct said submittals and resubmit.

In the event that in the process of development of the submittals it is discovered that there are defects and/or errors on the Plans that result in conflict between said Plans and the submittals, or if the submittals show variation from the Plans or other Contract Documents because of standard shop practice or other reasons, the Contractor shall thoroughly describe and explain said defects and/or conflicts in his or her transmittal letter to the Engineer.

The Engineer's review of the submittals will be for general design and arrangement only, and shall not relieve the Contractor from responsibility for errors of any sort in the submittals or of the responsibility for executing the work in accordance with the Contract Documents. The Contractor shall be solely responsible for the correctness of the submittals, for shop fits and field connections, and for the results obtained by use of such submittals. The Contractor shall verify and be fully responsible for all dimensions and job-site conditions affecting the Work and shall be responsible for furnishing and installing the proper materials required by the Contract Documents.

The Contract Time will not be extended due to the failure of the Contractor to provide submittals as required by the Contract Documents in a timely manner.

**2-9 SURVEYING**

**2-9.2 Survey Service**

*Add the following at the end of Subsection 2-9.2:*

The Contractor shall preserve bench marks, survey monuments, survey stakes and points set for lines, grades or measurements of Work in their proper places unless removal is authorized by the Engineer. The Contractor shall bear the cost of one (1) set of construction stakes, by an Agency approved surveyor. The Contractor shall provide the Agency with one copy of the survey. The cost of additional restaking, due to Contractor negligence shall also be borne by the Contractor. The costs for this service shall be included in the bid section for Mobilization.

**2.11 INSPECTION**

*Add the following at the end of Subsection 2-11:*

Should the Contractor elect to continue construction after a Stop Work Notice is issued, the Agency shall reject all work completed after the Stop Work Noticed issuance and the Agency will not be responsible for payment of the work; and/or the Agency shall require the Contractor to remove and replace all work completed, fully at the Contractor's cost after the Stop Work Notice issuance.

Inspection of the Work shall not relieve the Contractor of any of his obligations to fulfill the Contract. The Engineer shall have authority to stop Work whenever provisions of Contract Documents are not being complied with and such noncompliance is discovered. The Contractor shall remedy defective Work and the Agency may reject unsuitable materials, even if such defective Work or materials have been previously approved by the Engineer or included in the

quantities for progress payments. The Inspector cannot authorize deviations from the Plans and Specifications, and does not have the authority to obligate the Agency financially.

If any Work is concealed or performed without the requisite inspection notice, then the Work shall be subject to such tests or exposure as may be necessary to prove to the Engineer that the materials used and the Work performed are in conformity with the Plans and Specifications, or said materials or Work may be removed and installed or performed again at the discretion of the Agency Engineer. All labor, equipment, and materials necessary for exposing, testing, or complete removal, and installation or replacement shall be furnished by the Contractor at its own expense. The Contractor shall replace, at its own expense, any materials or Work damaged by exposure or testing.

Cost of rework inspection incurred by the Agency will be deducted from the Contract Price via Change Order. Rework inspection cost is as follows:

1. The Contractor's failure to complete the Work within the Contract Time, including any previously authorized extensions thereof.
2. Extra inspections required for the Contractor's correction of defective Work.
3. Overtime costs for acceleration of work done for the Contractor's convenience.
4. All associated costs including travel.

## SECTION 3 – CHANGES IN WORK

### 3-1 CHANGES REQUESTED BY THE CONTRACTOR

#### 3-1.1 General

*Add the following at the end of Subsection 3-1.1:*

If the Contractor alleges that instructions issued after the date of the Contract will result in increases to the Contract Price or Contract Time, if latent or unforeseen conditions require modification of the Contract Documents, or the Contractor otherwise becomes aware of the need for or desirability of a change in the Work, a Change Order Proposal (“COP”) may be submitted to the Agency in writing, using the forms provided herein in Subsection 3-6.2 of the Special Provisions, and must specify the reasons for such change, including relevant circumstances and impacts on the construction schedule. The Contractor may request additional compensation and/or time through a COP but not for instances that occurred more than **ten (10) Calendar Days** prior to the COP. The Contractor’s failure to initiate a COP within such period shall be deemed a waiver of the right to adjustment of the Contract Price or the Contract Time for the alleged change. Any COP that is approved by the Agency will be incorporated in a Change Order or Construction Change Directive. If the Agency determines that the Work in question is not a change, the Owner shall issue a Work Directive, ordering the Contractor to proceed with the Work without delay. If the COP is denied but the Contractor believes that it does have merit, the Contractor may submit a claim to the Agency.

### 3-2 CHANGES INITIATED BY THE AGENCY

#### 3-2.1 General

*Add the following at the end of Subsection 3-2.1:*

The Agency reserves the right to make changes in the Work, including the elimination of any Bid Item, after execution of the Contract and without invalidating the Contract by:

- A. Change Order approved by the City Council, Board, City Manager, Director, or Agency Engineer (dollar value of approval authority for each as per Agency policy); or
- B. Construction Change Directive approved by the City Council, Board, City Manager, Director, or Agency Engineer (dollar value of approval authority for each as per Agency policy);

A change that causes the total value of all changes to exceed the Contract contingency amount established at the time of award of the Contract must be approved by the Board. No payments in excess of the original Contract Price will be made until a Change Order is approved in the normal course of business. The Agency may, at any time, without notice to the Contractor’s surety(ies), order changes in the Work within the general scope of the Contract. Such changes in the Work shall not relieve or release the surety(ies) of its(their) obligations under the Performance and Payment Bonds issued for the Project. Changes in the Work made pursuant to this Article 3 shall in no way release any guarantee or warranty provided by the Contractor.

The Agency may issue a Change Order Proposal Request (“COPR”), in writing, to the Contractor, describing a proposed change to the Work and requesting that the Contractor submit an itemized Change Order Proposal (“COP”) to the Agency, using the forms provided herein in Subsection 3-6.2 of the Special Provisions, within **ten (10) Calendar Days** after the Agency’s issuance of the COPR. If the Contractor fails to submit a COP within such period of time, it shall be presumed that the change described in the Agency’s COPR will not result in an increase to the Contract Price or Contract Time and the change shall be performed by the Contractor without such increases. A COPR does not authorize the Contractor to commence performance of the changed work. The Contractor shall not perform any change until receipt of the Agency’s written approval. If the Agency approves the Contractor’s COP, Owner shall issue a Change Order or Construction Change Directive.

Whenever a change is pending, the Contractor shall notify the Agency if it is necessary to halt other Work in the area of the change that would be affected thereby, until such time as the change is authorized.

Any change to the Contract Price shall be in a sum mutually agreed to by the Contractor and the Agency, except that when, in the opinion of the Agency, such basis is not feasible, the change to the Contract Price shall be determined as provided for in Subsection 3-3, “Extra Work,” of the Standard Specifications and the Special Provisions.

**3-2.1.1 Change Order**

A Change Order is a written instrument prepared by the Agency and signed by the Agency and the Contractor, stating their agreement upon all of the following:

- A. The scope of the change in the Work;
- B. The amount of the adjustment, if any, in the Contract Price; and
- C. The extent of the adjustment, if any, in the Contract Time.

**3-2.1.1.1 Accord and Satisfaction**

The Contractor’s agreement on any Change Order shall be a full compromise and settlement of all adjustments to the Contract Time and Contract Price, and compensation for any and all delay, extended or additional field and home office overhead, disruption, acceleration, inefficiencies, lost labor or equipment productivity, differing site conditions, construction interferences, and other extraordinary or consequential damages (hereinafter called “Impacts”), including any ripple or cumulative effect of said Impacts on the overall Work under the Contract arising directly or indirectly from the performance of Work described in the Change Order. By execution of any Change Order, The Contractor agrees that the Change Order constitutes a complete accord and satisfaction with respect to all claims for schedule extension, Impacts, or any costs of whatsoever nature, character or kind arising out of or incidental to the Change Order. No action, conduct, omission, product failure, or course of dealing by the Agency shall act to waive, modify, change, or alter the requirement that Change Orders must be in writing, signed by the Agency and the Contractor, and that such written Change Orders are the exclusive method for effectuating any change to the Contract Sum and/or Contract Time.

### 3-2.1.2 Construction Change Directive

A Construction Change Directive is a written order prepared and signed by the Agency, directing a change in the Work prior to the Contractor's agreement on adjustment, if any, in the Contract Price or Contract Time, or both. The Agency may by Construction Change Directive, without invalidating the Contract, order changes in the Work within the general scope of the Contract consisting of additions, deletions or other revisions, the Contract Price and Contract Time being adjusted accordingly. Upon receipt of a Construction Change Directive, the Contractor shall promptly proceed with the change in the Work involved. A Construction Change Directive shall be used in the absence of total agreement on the terms of a Change Order. The Agency's form of Construction Change directive is provided in Subsection 3-6.2 of the Special Provisions.

### 3-2.2.2 Increases of More than 25 Percent

*Delete Subsection 3-2.2.2 in its entirety and substitute the following:*

Should the actual quantity of a Major Item of Work covered by a Contract Unit Price and constructed in conformance with the Plans and Specifications exceed the Bid quantity by more than 25 percent, a Change Order will be issued and payment for the quantity in excess of 25 percent of the Bid quantity will be made on the basis of an adjustment to the Contract Unit price mutually agreed to by the Agency and the Contractor or pursuant to Subsection 3-2.4 "Agreed Prices."

For Minor Items of Work, the Contractor will be paid using the Contract Unit Price, regardless of whether the actual quantity of the Minor Item of Work covered by a Contract Unit Price exceeds the bid quantity by more than 25 percent.

### 3-2.2.3 Decreases of More than 25 Percent

*Delete Subsection 3-2.2.3 in its entirety and substitute the following:*

Should the actual quantity of a Major Item of Work covered by a Contract Unit Price and constructed in conformance with the Plans and Specifications be less than 75 percent of the Bid quantity, an adjustment in payment will not be made unless so requested in writing by the Contractor. If the Contractor so requests, a Change Order shall be issued and payment shall be made on the basis of an adjustment to the Contract Unit Price mutually agreed to by the Agency and the Contractor, or pursuant to Subsection 3-2.4 "Agreed Prices"; however, in no case will payment be less than would be made for the actual quantity at the Contract Unit Price.

For Minor Items of Work, the Contractor will be paid using the Contract Unit Price, regardless of whether the actual quantity of the Minor Item of Work covered by a Contract Unit Price is less than 75 percent of the Bid quantity.

### 3-2.2.4 Changes for Items Not Covered by Unit Prices

Payment for any change for an Item of Work not covered by a Contract Unit Price shall be made pursuant to Subsection 3-3 "Extra Work."



### 3-3 EXTRA WORK

#### 3-3.1 General

*Add the following at the end of Subsection 3-3.1:*

The Contractor shall not perform any Extra Work except upon written authorization from the Engineer.

All Extra Work shall conform to the Plans and Specifications.

The Contractor shall furnish to the Engineer each subcontractor's signed detailed estimate of the cost for labor, materials, and equipment, including the markup by such subcontractor for overhead and profit for Work added or deducted to a subcontractor's scope of Work. The Contractor shall furnish to the Engineer the Sub-subcontractor's signed detailed estimate of the cost for labor, materials, and equipment, including the markup by such sub-subcontractor for overhead and profit for Work added or deducted to a sub-subcontractor's scope of Work. The Contractor shall furnish to the Engineer the vendor or supplier's signed detailed estimate or quotation of the cost to the Contractor for Work added or deducted from a vendor or supplier's scope of Work.

#### 3-3.2.1 General

*Add the following at the end of Subsection 3-3.2.1*

Any change in the Work for an Item of Work not covered by a Contract Unit Price that involves both added and deleted Work shall be paid on the basis of the net total cost. The cost of deleted Work not covered by a Contract Unit Price shall be determined by the Engineer based on the schedule of lump sum prices submitted by the Contractor in accordance with Subsection 9-2, "Lump Sum Work," of the Standard Specifications and the Special Provisions.

#### 3-3.2.2.1 Labor

*Delete Subsection 3-3.2.2.1 in its entirety and substitute the following:*

The cost of labor will be the actual cost for wages prevailing locally for each craft or type of worker (including foreman when authorized by the Engineer) performing the Extra Work at the time the Extra Work is done, plus liability insurance, health and welfare, pension, vacation, apprenticeship funds, and other direct costs, as well as assessments or benefits required by lawful collective bargaining agreements.

To the actual wages, as defined above, will be added a labor surcharge set forth in the California Department of Transportation publication entitled "Labor Surcharge and Equipment Rental Rates" that is in effect on the date upon which the Extra Work is performed. The labor surcharge shall constitute full compensation for all payments imposed by State and federal laws and for all other payments made to, or on behalf of, the workers, other than actual wages, subsistence and travel paid to the workers. The labor surcharge includes Workers' Compensation, Social Security, Medicare, Federal Unemployment, State Unemployment, and State Training taxes.

Except when direct supervision is provided by working foremen whose time is included in accordance with Subsection 3-2.2.2, the cost of direct supervision of Extra Work, when such direct supervision is provided exclusively for the Extra Work and not in conjunction with or at the same time as supervision for other Work, and when approved in advance in writing by the Engineer, may be charged to the Extra Work. Such cost includes only the actual cost of supervision labor, plus payroll taxes, insurance, and pension costs. The cost of transportation, use of vehicle, and other costs incurred by supervision will not be allowed.

**3-3.2.2.2 Materials**

*Add the following to Subsection 3-3.2.2.2:*

If the Contractor does not furnish satisfactory evidence of the cost of the materials from the actual supplier thereof within a specified time period after the date of delivery of material, the Engineer reserves the right to establish the cost of the materials at the lowest current wholesale prices at which the materials were available, in the quantities concerned, delivered to the location of the Work site, less any discounts.

**3-3.2.2.3 Tool and Equipment Rental**

*Delete Subsection 3-3.2.2.3 in its entirety and substitute the following:*

No payment will be made for individual pieces of equipment or tools not listed in the California Department of Transportation publication entitled "Labor Surcharge and Equipment Rental Rates" that is in effect on the date upon which the Extra Work is performed and that have a replacement value of \$200 or less, whether or not consumed by use. Such equipment or tools shall be considered to be small tools.

The Contractor will be paid for the use of equipment at the rental rates listed for such equipment in the Labor Surcharge and Equipment Rental Rates publication that is in effect on the date upon which the Extra Work is performed.

Move in and out, or minimum charges other than the hourly rate, shall not apply to equipment available from the force already on the Project site.

For equipment that is rented from a local equipment agency, the Contractor will be paid at the hourly rate shown on the rental agency invoice or agreement for the time the equipment is used on Extra Work. If a minimum equipment rental amount is required by the local equipment rental agency, the actual amount charged will be paid to the Contractor.

If it is deemed necessary by the Engineer to use equipment not listed in the Labor Surcharge and Equipment Rental Rates publication, a suitable rental rate for that equipment will be established by the Engineer. The Contractor may furnish any cost data that might assist the Engineer in the establishment of the rental rate. If the rental rate established by the Engineer is \$10.00 per hour or less, the provisions above concerning rental of equipment from a local equipment agency shall apply.

Rental time will not be allowed while equipment is inoperative due to breakdowns.

When owner operated equipment is used to perform Extra Work to be paid on a force account basis, the Contractor will be paid for the equipment and operator as follows:

SPECIAL PROVISIONS  
PART 1 – GENERAL PROVISIONS  
00701-19

1. Payment for the equipment will be made at the rental rates listed for such equipment in the Labor Surcharge and Equipment Rental Rates publication that is in effect on the date upon which the Extra Work is performed.
2. Payment for the cost of labor will be made in conformance with the provisions in Subsection 3-3.2.2.1 "Labor" of the Special Provisions.

### 3-3.2.3 Markup

*Delete Subsection 3-3.2.3 in its entirety and substitute the following:*

The markup for overhead and profit on Extra Work shall be in accordance with the following schedule.

**3-3.2.3.1 Work by Contractor.** For Extra Work performed by the Contractor's forces, the following percentages shall be added to the Contractor's costs and shall constitute the markup for all overhead and profit: twenty percent (20%) for labor, fifteen percent (15%) for materials, and fifteen percent (15%) for equipment rentals.

**3-3.2.3.2 Work by Subcontractor.** For Extra Work performed by a subcontractor, the markup established in Subsection 3-3.2.3.1 of the Special Provisions shall be applied to the subcontractor's costs. An additional five percent (5%) shall be added to the subcontractor's final cost, which shall reimburse the Contractor for administrative costs, including overhead and profit.

**3-3.2.3.3 Work by sub-subcontractor.** For Extra Work performed by a sub-subcontractor, the markup established in Subsection 3-3.2.3.1 of the Special Provisions shall be applied to the sub-subcontractor's costs. An additional ten percent (10%) shall be added to the sub-subcontractor's final cost, five percent (5%) of which shall reimburse the Contractor for administrative costs, including overhead and profit, and five percent (5%) of which shall reimburse the subcontractor for administrative costs, including overhead and profit.

**3-3.2.3.4 Work by Specialist.** If the Engineer and the Contractor agree that a service or an item of Extra Work cannot be performed by the forces of the Contractor or those of any of its subcontractors or sub-subcontractors, such service or Extra Work item may be performed by a specialist. Invoices for such services or items of Extra Work calculated on the basis of current market prices may be accepted without complete itemization of labor, material, and equipment rental costs when it is impracticable and not in accordance with the established practice of the special service industry to provide such complete itemization.

If the Contractor is required to perform Extra Work that requires a fabrication or matching process in a fabrication or machine shop facilities away from the Project site, the charges for that portion of the Extra Work performed in such facility may, by agreement between the Contractor and Engineer, be accepted as a specialist billing.

For Extra Work performed by a specialist, fifteen percent (15%) shall be added to the specialist's invoice price less a credit to the Agency for any cash or trade discount offered or available, whether or not such discount may have been taken; such percentage shall reimburse the Contractor for administrative costs, including overhead and profit.

**3-3.2.3.5 Work not Covered by Unit Prices.** Markup for overhead and profit on any change in the Work for an Item of Work not covered by a Contract Unit Price that involves both added and deleted Work shall be paid, in accordance with this Subsection 3-3.2.3 of the Special Provisions, only if the net cost increases the Contract Price (i.e. if the cost for added Work exceeds the cost for deleted Work).

**3-3.3 Daily Reports by Contractor**

*Delete the first sentence of Subsection 3-3.3 and substitute the following:*

The Contractor shall submit daily reports for Extra Work showing all labor, material, and equipment costs incurred.

*Add the following at the end of Subsection 3-3.3:*

The daily reports shall describe in detail the Extra Work that was performed and the location (station, etc.). Separate daily reports shall be submitted for Extra Work that is performed for more than one location and for different tasks that are performed on the same day. Material charges shall be substantiated by valid copies of vendor's invoices. Such invoices shall be submitted with the daily reports, or if not available, they shall be submitted with subsequent daily reports. The Contractor shall maintain the Contractor's records in such a manner as to provide a clear accounting of the costs.

Upon completion of the Extra Work, the Contractor shall submit a summary of costs, including markup for overhead and profit. All costs shall be in accordance with Subsection 3-3.2, "Payment," of the Standard Specifications and the Special Provisions. The signature of the Agency's Inspector on a daily report shall indicate agreement with the information reflected therein, not that the Contractor is entitled to payment of the costs in the report. The Engineer shall review the daily reports. The Engineer shall compare Inspector's records with the completed daily reports furnished by the Contractor and make any necessary adjustments. When the daily reports are agreed upon and signed by both parties, said reports shall become the basis of payment for the Extra Work performed.

**3-3.4 Extension of Time**

If the Contractor is delayed in completing the Extra Work due to a change ordered by the Agency, the time for completion of Work will be extended for a period equal to the number of days by which the entire Project has been delayed because of such change. The Contractor will not be liable for liquidated damages for such period of time and shall have no claim for any additional compensation for any such delay except as otherwise provided in the Standard Specifications or Special Provisions.

**3-5 DISPUTED WORK**

*Delete Subsection 3-5 in its entirety and substitute the following:*

In the event of disputed Work, the Agency shall have the right to unilaterally issue a written Work Directive and Contractor shall continue performance pending resolution of the dispute and shall maintain cost data described in Subsection 3-3 of the Standard Specifications and the Special Provisions. The Agency's form of Work Directive is provided in Subsection 3-6 of the Special Provisions. Payment shall be made for such disputed Work as is later determined by negotiation between the parties or as is fixed by a court of law.

### **3-6 FORMS**

#### **3-6.1 Change Order Form**

#### **3-6.2 Change Order Proposal Forms**

- (a) Change Order Proposal Summary Report
- (b) Labor Cost Report
- (c) Labor Rates Report
- (d) Material Cost Report
- (e) Equipment Cost Report
- (f) Special Forces/Services Cost Report

#### **3-6.3 Construction Change Directive Form**

#### **3-6.4 Work Directive Form**



**CITY OF MORENO VALLEY  
PARKS AND COMMUNITY SERVICES DEPARTMENT  
Administration Division**

**CONTRACT CHANGE ORDER NO. 1 (Final)**

PROJECT NO.:

DESCRIPTION:

TO: **Construction Company, Inc.**

You are hereby requested to comply with the following changes from the Contract Plans and Specifications:

| SUMMARY OF CHANGES                             |  |
|--|--|
| Description<br>(Detailed Explanation Attached) | Change in<br>Contract Price <sup>1</sup> |
| 1.   | \$0.00                                   |
| 2. Adjustment in Final Bid Quantities          | \$0.00                                   |
| <b>Net Change in Contract Price</b>            | <b>\$0.00</b>                            |

<sup>1</sup> Deduction or decrease in Contract Price is denoted in parentheses

The following change is hereby made a part of the Contract Documents and shall be performed under the same terms and conditions as required by the original Contract Documents. Except as modified herein, the original Contract Documents and all prior amendments shall remain in full force and effect and all of the terms of the Contract Documents are hereby incorporated in this Change Order.

**SUMMARY OF ALL CHANGE ORDERS**

|                                |              |
|--------------------------------|--------------|
| ORIGINAL CONTRACT AMOUNT ..... | \$000,000.00 |
| CCO1 (FINAL) .....             | \$0.00       |
| TOTAL .....                    | \$000,000.00 |

**SUMMARY OF WORKING DAYS**

FIRST DAY OF WORK:..... Date  
 CONTRACT WORKING DAYS: ..... X  
 TIME EXTENSION:  
     CCO 1 (Final)..... Y  
 NEW TOTAL WORKING DAYS: ..... X+Y  
 LAST DAY OF WORK: ..... New Date

SPECIAL PROVISIONS  
PART 1 – GENERAL PROVISIONS  
00701-23

Attachment: SPECIAL PROVISIONS - MVCP SKATE PARK (3355) : APPROVE AND EXECUTE AGREEMENT WITH MICON CONSTRUCTION FOR

### CHANGE ORDER DETAIL

Change Order No.: **1 (Final)**

Project No.:

Description:

The changes or interpretations described and noted herein are hereby authorized. The signed original of this order is on file in the Department of Public Works. Shown as separate paragraphs: (A) Reason for Change; (B) Description of Change; (C) Change in Contract Costs; and (D) Change in Completion Date.

**Item No. 1:**

A. Reason for Change:

B. Description of Change:

| ITEM     | DESCRIPTION | UNIT | UNIT PRICE | BID OR CURRENT APPROVED QTY | FINAL QTY | CHANGE | CHANGE IN COST <sup>1</sup> |
|----------|-------------|------|------------|-----------------------------|-----------|--------|-----------------------------|
| New Item |             |      |            | 0                           | 0         | 0      | 0.00                        |

C. Change in Contract Cost:  
Add \$0.00

D. Change in Completion Date:  
Add Y Working Days

**Item No. 2: Adjustment in Final Bid Quantities:**

A. Reason for Change:  
Due to conditions encountered during construction, modifications to the amount of Work were determined to be appropriate, and the changes were addressed by means of adjusting applicable contract quantities, as outlined below.

B. Description of Change:

| ITEM | DESCRIPTION | UNIT | UNIT PRICE | BID OR CURRENT APPROVED QTY | FINAL QTY | CHANGE | CHANGE IN COST <sup>1</sup> |
|------|-------------|------|------------|-----------------------------|-----------|--------|-----------------------------|
|      |             |      |            |                             |           |        |                             |
|      |             |      |            |                             |           |        |                             |
|      |             |      |            |                             |           |        |                             |
|      |             |      |            |                             |           |        |                             |
|      |             |      |            |                             |           |        |                             |
|      |             |      |            |                             |           |        |                             |

<sup>1</sup>Deduction or decrease in Contract Price is denoted in parentheses

C. Change in Contract Cost:  
Add \$0.00

D. Change in Completion Date:  
No Change.

**SIGNATURE PAGE TO FOLLOW:**



The original Contract Price was and 00/100 Dollars (\$0.00). Contract Change Order No.1 (Final) increased the Contract Price by 00/100 Dollars (\$0.00). The new Contract Price will be 00/100, resulting in an increase of approximately 0.00% to the original Contract.

The original Contract Time of X(x) Working Days was extended by Y (y) Working Days per Change Order No. 1 (Final). The last contract Working Day is new Date.

Ordered: \_\_\_\_\_ Date: \_\_\_\_\_  
Director

Concurred by: \_\_\_\_\_ Date: \_\_\_\_\_  
Project Manager

Acceptance by the Contractor:

This Change Order is in full compromise and settlement of all adjustments to Contract Time and Contract Price, and compensation for any and all delay, extended or additional field and home office overhead, disruption, acceleration, inefficiencies, lost labor or equipment productivity, differing site conditions, construction interferences and other extraordinary or consequential damages (hereinafter called "Impacts"), including any ripple or cumulative effect of said Impacts on the overall Work under the Contract arising directly or indirectly from the performance of Work described in this Change Order. By execution of this Change Order, the Contractor agrees that this Change Order constitutes a complete accord and satisfaction with respect to all claims for schedule extension, Impacts, or any costs of any nature, character or kind arising out of or incidental to this Change Order.

Name: \_\_\_\_\_ Date: \_\_\_\_\_

Title: \_\_\_\_\_

Attachment: SPECIAL PROVISIONS - MVCP SKATE PARK (3355 : APPROVE AND EXECUTE AGREEMENT WITH MICON CONSTRUCTION FOR

CHANGE ORDER PROPOSAL FORM

3-6.2(a) CONTRACT CHANGE ORDER PROPOSAL SUMMARY REPORT

Date \_\_\_\_\_

CCO Proposal No. \_\_\_\_\_

Contractor \_\_\_\_\_

Item No. \_\_\_\_\_

Location \_\_\_\_\_

AMOUNT

General Contractor

1. Labor Cost:..... \$ \_\_\_\_\_

2. Material Cost:..... \$ \_\_\_\_\_

3. Equipment Cost:..... \$ \_\_\_\_\_

4. Special Forces/Services:..... \$ \_\_\_\_\_

**Subtotal Contractor Cost:..... \$ \_\_\_\_\_**

5. Subcontractor/Sub-subcontractor Name \_\_\_\_\_

a. Labor Cost..... \$ \_\_\_\_\_

b. Material Cost..... \$ \_\_\_\_\_

c. Equipment Cost..... \$ \_\_\_\_\_

**Subtotal Subcontractor/Sub-subcontractor Cost..... \$ \_\_\_\_\_**

6. Subcontractor/Sub-subcontractor Name \_\_\_\_\_

a. Labor Cost..... \$ \_\_\_\_\_

b. Material Cost..... \$ \_\_\_\_\_

c. Equipment Cost..... \$ \_\_\_\_\_

**Subtotal Subcontractor/Sub-subcontractor Cost..... \$ \_\_\_\_\_**

**TOTAL CONTRACT CHANGE ORDER COSTS..... \$ \_\_\_\_\_**

Attachment: SPECIAL PROVISIONS - MVCP SKATE PARK (3355 : APPROVE AND EXECUTE AGREEMENT WITH MICON CONSTRUCTION FOR

CHANGE ORDER PROPOSAL FORM

3-6.2(b) LABOR COST REPORT

Date \_\_\_\_\_

CCO Proposal No. \_\_\_\_\_ Contractor or Subcontractor \_\_\_\_\_

Item No. \_\_\_\_\_ Location \_\_\_\_\_

| CLASSIFICATION AND NAME | HOURS | HOURLY RATE | EXTENDED AMOUNTS |
|-------------------------|-------|-------------|------------------|
| Classification:         | OT    | \$          | \$               |
| Name:                   | REG   | \$          | \$               |
| Classification:         | OT    | \$          | \$               |
| Name:                   | REG   | \$          | \$               |
| Classification:         | OT    | \$          | \$               |
| Name:                   | REG   | \$          | \$               |
| Classification:         | OT    | \$          | \$               |
| Name:                   | REG   | \$          | \$               |
| Classification:         | OT    | \$          | \$               |
| Name:                   | REG   | \$          | \$               |
| <b>TOTAL LABOR</b>      |       |             | <b>\$</b>        |

Overhead/profit 20%..... \$ \_\_\_\_\_

Total labor/overhead/profit..... \$ \_\_\_\_\_

Subcontractor's mark-up of total Sub-subcontractor labor/overhead/profit (if applicable) 5%..... \$ \_\_\_\_\_

General contractor's mark-up of total Subcontractor or Sub-subcontractor labor/overhead/profit (if applicable) 5% ..... \$ \_\_\_\_\_

**Total**..... \$ \_\_\_\_\_

SPECIAL PROVISIONS  
PART 1 – GENERAL PROVISIONS  
00701-28

Attachment: SPECIAL PROVISIONS - MVCP SKATE PARK (3355 : APPROVE AND EXECUTE AGREEMENT WITH MICON CONSTRUCTION FOR

**CHANGE ORDER PROPOSAL FORM**

**3-6.2(c) LABOR RATES REPORT**

Date \_\_\_\_\_

CCO Proposal No. \_\_\_\_\_ Contractor or Subcontractor \_\_\_\_\_

Item No. \_\_\_\_\_ Location \_\_\_\_\_

| CLASSIFICATION:                            |           |           |
|--|-----------|-----------|
|  |           |           |
| TAXABLE BASE:                              |           | AMOUNT    |
| Base Hourly Pay                            |           | \$        |
| Vacation                                   |           | \$        |
| <b>TOTAL TAXABLE BASE</b>                  |           | <b>\$</b> |
| TAXES & INSURANCE                          | PERCENT   | AMOUNT    |
| Social Security Tax                        |           | \$        |
| State Unemployment Tax                     |           | \$        |
| Federal Unemployment Tax                   |           | \$        |
| Workmen's Compensation                     |           | \$        |
| Liability & Umbrella Insurance             |           | \$        |
| <b>TOTAL TAXES &amp; INSURANCE</b>         |           | <b>\$</b> |
| FRINGE BENEFITS                            | AMOUNT    |           |
| Pension                                    | \$        |           |
| Health & Welfare                           | \$        |           |
| Training                                   | \$        |           |
| Other Fringe Benefits                      | \$        |           |
| <b>TOTAL FRINGE BENEFITS</b>               | <b>\$</b> |           |
| <b>TOTAL LABOR RATE PER CLASSIFICATION</b> | <b>\$</b> |           |

SPECIAL PROVISIONS  
 PART 1 – GENERAL PROVISIONS  
 00701-29

Attachment: SPECIAL PROVISIONS - MVCP SKATE PARK (3355 : APPROVE AND EXECUTE AGREEMENT WITH MICON CONSTRUCTION FOR

**CHANGE ORDER PROPOSAL FORM**

**3-6.2(d) MATERIAL COST REPORT**

Date \_\_\_\_\_

CCO Proposal No. \_\_\_\_\_ Contractor or Subcontractor \_\_\_\_\_

Item No. \_\_\_\_\_ Location \_\_\_\_\_

| INVOICE NO.                   | DESCRIPTION                           | AMOUNT   |
|-------------------------------|---------------------------------------|----------|
| 1.                            | Material                              | \$ _____ |
|                               | Sales Tax (Prevailing Tax Rate) 7.75% | \$ _____ |
| <b>Subtotal</b>               |                                       | \$ _____ |
| 2.                            | Material                              | \$ _____ |
|                               | Sales Tax (Prevailing Tax Rate) 7.75% | \$ _____ |
| <b>Subtotal</b>               |                                       | \$ _____ |
| 3.                            | Material                              | \$ _____ |
|                               | Sales Tax (Prevailing Tax Rate) 7.75% | \$ _____ |
| <b>Subtotal</b>               |                                       | \$ _____ |
| <b>SUBTOTAL MATERIAL COST</b> |                                       | \$ _____ |

**NOTE: An itemized list of materials, manufacturers, serial numbers, invoices, and other pertinent data shall be submitted along with the material cost report.**

Overhead/profit 15%..... \$ \_\_\_\_\_

Total material/overhead/profit..... \$ \_\_\_\_\_

Subcontractor's mark-up of total Sub-subcontractor material/overhead/profit (if applicable) 5%..... \$ \_\_\_\_\_

General contractor's mark-up of total Subcontractor or Sub-subcontractor material/overhead/profit (if applicable) 5%..... \$ \_\_\_\_\_

**Total**..... \$ \_\_\_\_\_

SPECIAL PROVISIONS  
PART 1 – GENERAL PROVISIONS  
00701-30

Attachment: SPECIAL PROVISIONS - MVCP SKATE PARK (3355 : APPROVE AND EXECUTE AGREEMENT WITH MICON CONSTRUCTION FOR

**CHANGE ORDER PROPOSAL FORM**

**3-6.2(e) EQUIPMENT COST REPORT**

Date \_\_\_\_\_

CCO Proposal No. \_\_\_\_\_ Contractor or Subcontractor \_\_\_\_\_

Item No. \_\_\_\_\_ Location \_\_\_\_\_

**3-6.2 (e) EQUIPMENT COST REPORT**

| EQUIPMENT NO.<br>(Description, Type, Size) | HOURS | HOURLY<br>RATE | EXTENDED<br>AMOUNTS |
|--|-------|----------------|---------------------|
|  |       |                |                     |
|  |       |                |                     |
|  |       |                |                     |
|  |       |                |                     |
|  |       |                |                     |
|  |       |                |                     |
|  |       |                |                     |
|  |       |                |                     |
|  |       |                |                     |
| <b>SUBTOTAL EQUIPMENT COST</b>             |       |                | \$ _____            |

Overhead/profit 15%..... \$ \_\_\_\_\_

Total equipment/overhead/profit..... \$ \_\_\_\_\_

Subcontractor's mark-up of total Sub-subcontractor  
equipment/overhead/profit (if applicable) 5%..... \$ \_\_\_\_\_

General contractor's mark-up of total Subcontractor  
or Sub-subcontractor equipment/overhead/profit (if applicable) 5%..... \$ \_\_\_\_\_

**Total**..... \$ \_\_\_\_\_

SPECIAL PROVISIONS  
PART 1 – GENERAL PROVISIONS  
00701-31

Attachment: SPECIAL PROVISIONS - MVCP SKATE PARK (3355 : APPROVE AND EXECUTE AGREEMENT WITH MICON CONSTRUCTION FOR

**CHANGE ORDER PROPOSAL FORM**

**3-6.2 (f) SPECIAL FORCES/SERVICES COST REPORT**

Date \_\_\_\_\_

CCO Proposal No. \_\_\_\_\_ Contractor or Subcontractor \_\_\_\_\_

Item No. \_\_\_\_\_ Location \_\_\_\_\_

| INVOICE NO.                   | DESCRIPTION | AMOUNT |
|-------------------------------|-------------|--------|
| 1.                            |             | \$     |
|                               |             | \$     |
| <b>Subtotal</b>               |             | \$     |
| 2.                            |             | \$     |
|                               |             | \$     |
| <b>Subtotal</b>               |             | \$     |
| 3.                            |             | \$     |
|                               |             | \$     |
| <b>Subtotal</b>               |             | \$     |
| <b>SUBTOTAL MATERIAL COST</b> |             | \$     |

**NOTE: An itemized list of materials, manufacturers, serial numbers, invoices, and other pertinent data shall be submitted along with the special forces/services cost report.**

Overhead/profit 15%..... \$ \_\_\_\_\_

**Total Special Forces/Services Overhead/Profit..... \$ \_\_\_\_\_**

SPECIAL PROVISIONS  
PART 1 – GENERAL PROVISIONS  
00701-32

Attachment: SPECIAL PROVISIONS - MVCP SKATE PARK (3355 : APPROVE AND EXECUTE AGREEMENT WITH MICON CONSTRUCTION FOR

3-6.3 CONSTRUCTION CHANGE DIRECTIVE

Distribution to: OWNER  CONTRACTOR  OTHER  PROJECT MANAGER

|                |                |
|----------------|----------------|
| PROJECT:       | DIRECTIVE NO.: |
|                | DATE:          |
|                | CONTRACT DATE: |
| TO CONTRACTOR: | CONTRACT FOR:  |

You are hereby directed to make the following change(s) to this Contract:

**PROPOSED ADJUSTMENTS**

1. The proposed basis of adjustment to the Contract Price is:
  - Lump Sum (increase) (decrease) of \$ \_\_\_\_\_.
  - Unit Price of \$ \_\_\_\_\_ per \_\_\_\_\_.
  - Daily time and materials records of actual costs plus a overhead and profit, as provided in **Subsection 3-3, "Extra Work," the Standard Specifications and the Agency's Special Provisions**, [subject to a Not-To-Exceed Amount of \$ \_\_\_\_\_].
  - as follows:
  
2. The Contract Time is proposed to (be adjusted) (remain unchanged). The proposed adjustment, if any, is (an increase of \_\_\_ days) (a decrease of \_\_\_ days).

If the Contractor disagrees with the proposed adjustments, it must submit its own proposal within 10 days of the date of this Construction Change Directive pursuant to Contract Documents or the proposed adjustment will become final and binding on the Contractor.

When signed by the Agency's and received by the Contractor, this document becomes effective IMMEDIATELY as a Construction Change Directive (CCD), and the Contractor shall proceed with the change(s) described above.

|                                       |             |
|---------------------------------------|-------------|
| Ordered: _____<br>Director            | Date: _____ |
| Concurred by: _____<br>Engineer       | Date: _____ |
| Prepared by: _____<br>Project Manager | Date: _____ |

SPECIAL PROVISIONS  
PART 1 – GENERAL PROVISIONS  
00701-33

Attachment: SPECIAL PROVISIONS - MVCP SKATE PARK (3355 : APPROVE AND EXECUTE AGREEMENT WITH MICON CONSTRUCTION FOR



3-6.4 WORK DIRECTIVE

Distribution to: OWNER  CONTRACTOR  FIELD  OTHER  PROJECT MANAGER

---

|                |                     |
|----------------|---------------------|
| PROJECT:       | WORK DIRECTIVE NO.: |
|                | DATE:               |
|                | CONTRACT DATE:      |
| TO CONTRACTOR: | CONTRACT FOR:       |

You are hereby directed to continue performance of the following Work, without delay, pending resolution of the dispute concerning such Work and maintain the cost data described in Subsection 3-3, "Extra Work," of the Standard Specifications and the **Agency's Special Provisions** to the Contract for the performance of such Work:

Neither the issuance of this Work Directive nor the requirement for the Contractor to maintain cost data constitutes approval by the Agency of a change in the Work or modification of the Contract Documents.

|                                       |             |
|---------------------------------------|-------------|
| Ordered: _____<br>Director            | Date: _____ |
| Concurred by: _____<br>Engineer       | Date: _____ |
| Prepared by: _____<br>Project Manager | Date: _____ |

SPECIAL PROVISIONS  
PART 1 – GENERAL PROVISIONS  
00701-34

Attachment: SPECIAL PROVISIONS - MVCP SKATE PARK (3355 : APPROVE AND EXECUTE AGREEMENT WITH MICON CONSTRUCTION FOR

## SECTION 4 - CONTROL OF MATERIALS

### 4-1 MATERIALS AND WORKMANSHIP

#### 4-1.1.1 Property Rights in Materials

Nothing in the Contract shall be construed as vesting in the Contractor any right, title, or interest in material used in the Work after it has been attached or affixed to the Work or the soil. All such material shall become the property of the Agency upon being so attached or affixed.

#### 4-1.2 Protection of Work and Materials

*Add the following at the end of Subsection 4-1.2:*

Materials shall not be stored in the right-of-way unless written permission is given by the Engineer.

#### 4-1.4 Test of Materials

*Delete Subsection 4-1.4 in its entirety and substitute the following:*

Unless otherwise called for in these Special Provisions, all testing of materials will be performed by the Agency in such number and at such locations as deemed necessary by the Engineer to ensure compliance with the Contract Documents. The cost of all testing that can be performed within 50 miles of the Project will be borne by the Agency; the cost of all testing that must be performed 50 miles or more from the Project will be borne by the Contractor; the cost of all re-testing will be borne by the Contractor, and the amount due the Agency for said re-testing will be deducted from the Contract Price via Change Order.

The cost of rework material testing, overtime, travel and other related costs incurred by the Agency will be deducted from the Contract Price via Change Order.

#### 4-1.5 Certificate of Compliance

*Add the following at the end of Subsection 4-1.5:*

A certificate of compliance shall be furnished prior to the use of any materials for which the Standard Specifications or Special Provisions require that a certificate be furnished. In addition, when so authorized in the Standard Specifications or Special Provisions, the Engineer may permit the use of certain materials or assemblies prior to sampling and testing if accompanied by a certificate of compliance. The certificate shall be signed by the manufacturer of the material or the manufacturer of assembled materials, and shall state that the materials involved comply in all respects with the requirements of the Specifications. A certificate of compliance shall be furnished with each lot of material delivered to the Project and each lot shall be clearly identified in the certificate.

All materials used on the basis of a certificate of compliance may be sampled and tested at any time. The fact that material is used on the basis of a certificate of compliance shall not relieve the Contractor of responsibility for incorporating material in the Work which conforms to the requirements of the Contract Documents, and any material not conforming to the requirements will be subject to rejection, whether in place or not.

The Agency reserves the right to refuse to permit the use of material on the basis of a certificate of compliance.

**4-1.6 Trade Names or Equals**

*Add the following at the end of Subsection 4-1.6:*

The phrase "or equal" shall mean "or approved as equal in the opinion of the Engineer."

Within ten (10) Working Days after the date of Contract award, the Contractor shall, at its expense, submit a written request to the Engineer for each desired substitution for final evaluation by the Engineer. Each substitution request shall be accompanied by complete descriptive information from the manufacturer, samples as requested by the Engineer, complete detailed test results from a licensed independent testing laboratory of the Agency's choice if requested by the Engineer, and, if requested by the Engineer, an evaluation report from a qualified licensed professional engineer. If, in the Engineer's opinion, the requested substitution is of lesser quality or in variance with that specified, or if the information submitted is insufficient or incomplete, the requested substitution will not be approved and the specified materials or equipment shall be furnished. No request for substitutions submitted more than ten (10) Working Days after the date of Contract award will be considered.

In accordance with Public Contract Code Section 3400, the Agency may describe in the Notice Inviting Bids a finding that a particular material, product, thing, or service is designated by specific brand or trade name for any of the following purposes:

- 1. In order that a field test or experiment may be made to determine the product's suitability for future use.
- 2. In order to match other products in use on a particular public improvement either completed or in the course of completion.
- 3. In order to obtain a necessary item that is only available from one source.
- 4. A. In order to respond to an emergency declared by a local agency, but only if the declaration is approved by a four-fifths vote of the City Council.  
B. In order to respond to an emergency declared by the State, a State agency, or political subdivision of the State, but only if the facts setting forth the reasons for the finding of the emergency are contained in the public records of the City Council.

**4-1.10 Foreign Materials**

Materials which are manufactured, produced, or fabricated outside of the United States shall be delivered to a distribution point in California, unless otherwise required by the Standard Specifications or Special Provisions, where they shall be retained for a sufficient period of time to permit inspection, sampling, and testing.

The Contract Time shall not be extended due to acts or events occurring outside of the United States and it shall be the Contractor's responsibility to deliver materials obtained from outside of the United States to the point of entry into the continental United States in sufficient time to permit timely delivery to the Project site.

The cost of all testing that can be performed within 50 miles of the Project will be borne by the Agency; the cost of all testing that must be performed 50 miles or more from the Project will be borne by the Contractor; the cost of all re-testing will be borne by the Contractor, and the amount due the Agency for said re-testing will be deducted from the Contract Price via Change Order.

The manufacturer, producer, or fabricator of foreign material shall furnish to the Engineer a certificate of compliance in accordance with Subsection 4-1.5 of the Standard Specifications

and the Special Provisions. In addition, certified mill test reports or actual specimen tests clearly identifiable to the lot of material shall be furnished as required by the Standard Specifications or Special Provision, or as otherwise required by the Engineer.

If the welding of steel for structural steel members or the casting and prestressing of precast prestressed concrete members is to be performed outside of the United States, the following requirements shall apply:

- A. The fabrication shall be performed only within the plants and by fabricators who have previously established, to the satisfaction of the Engineer, that they have the experience, knowledge, trained manpower, quality controls, equipment and other facilities required to produce the quality and quantity of work required. At the option of the Engineer, prequalification of the plant and fabricator will be established either by the submission of detailed written proof thereof or through in-plant inspection by the Engineer or the Engineer's representative, or both.
- B. The Contractor shall make written application to the Engineer for approval for the foreign fabrication at the earliest possible time and in no case later than fifty (50) days in advance of the planned start of fabrication. The application shall list the specific units or portion of Work that will be fabricated outside of the United States.
- C. The Contractor shall advise the Engineer, in writing, at least twenty (20) days in advance of the actual start of any of the foreign fabrication.
- D. All documents pertaining to the foreign fabrication, including, but not limited to, correspondence, bids, proposals, working drawings, and data shall be written in the English language and all numerical data shall use the International System of Units (SI) for measurement.

#### 4-1.11 State Specification Number

The State specification number of material furnished under the Contract shall conform to the number specified in the Standard Specifications, Special Provisions, or Specifications issued after the Standard Specifications and Special Provisions.

## SECTION 5 – UTILITIES

### 5-1 LOCATION

Delete Subsection 5-1 in its entirety and substitute the following:

In accordance with California Government Code Section 4216 et seq., when Work is to be conducted in an area which is known, or reasonably known, to contain underground utilities or subsurface improvements, the Contractor shall contact Underground Service Alert of Southern California at least two (2) Working Days, but not more than 14 Calendar Days, in advance of any construction activity that will or could damage or affect any underground utility or subsurface improvement, and obtain an inquiry identification number (CGC 4216). The Contractor shall delineate with white paint or other suitable markings the area to be excavated. The Contractor shall notify Underground Service Alert in the event of change in the Project limits or change in original Work previously shown on the Plans or indicated in the Specifications. When all Work is completed, the Contractor shall remove all markings for underground utilities.

Subsurface installations are any underground pipeline, conduit, duct, wire, or other structure, except nonpressurized sewer lines, nonpressurized storm drains, or other nonpressurized drain lines. "Approximate location of subsurface installations" means a strip of land not more than 24 inches on either side of the exterior surface of the subsurface installation. "Approximate location" does not mean depth (CGC 4216). When the subsurface installation markings are no longer reasonably visible, the Contractor shall notify Underground Service Alert to remark those subsurface installations that may be affected by excavation to the extent necessary (CGC 4216.3(c)).

### 5-5 DELAYS

Add the following at the end of Subsection 5-5:

In accordance with California Government Code Section 4215, if such utilities have not been identified with reasonable accuracy in the Contract Documents, the Contractor shall be compensated for the cost of locating, repairing damage not due to the failure of the Contractor to exercise reasonable care, and removing or relocating such utility facilities not indicated in the Plans and Specifications with reasonable accuracy, and for equipment on the Project necessarily idled during such Work. The Contractor shall not be assessed liquidated damages for delay in completion of the Project, when such delay was caused by the failure of the Agency or the owner of the utility to provide for removal or relocation of such utility facilities.

### 5-7 AGENCY TELEPHONE NUMBERS

The following list of individuals or entities, which may have facilities in the area to be improved hereunder, is merely for the Contractor's information and may not be accurate or complete:

|   |              |
|---|--------------|
| Box Springs Mutual Water Company .....                              | 951.653.6419 |
| City of Moreno Valley Police Department .....                       | 951.486.6700 |
| City of Moreno Valley, Public Works Department .....                | 951.413.3100 |
| City of Moreno Valley, PW Operations & Facilities .....             | 951.413.3160 |
| City of Moreno Valley, Parks & Community Services .....             | 951.413.3280 |
| City of Moreno Valley, Parks Maintenance .....                      | 951.413.3702 |
| Eastern Municipal Water District .....                              | 800.426.3693 |
| Egdemont Community Services District (Albert A. Webb & Assoc.) .... | 951.686.1070 |

|  |              |
|--|--------------|
| Moreno Valley Unified School District .....          | 951.485.5600 |
| Moreno Valley Utilities (Electrical).....            | 877.811.8700 |
| Questar Southern Trails.....                         | 714.379.3376 |
| Riverside Transit Agency.....                        | 951.684.0850 |
| SBC (formerly Pacific Bell) .....                    | 800.750.2355 |
| Southern California Edison Company .....             | 800.684.8123 |
| Southern California Gas Company (Distribution).....  | 909.335.3919 |
| Southern California Gas Company (Transmission) ..... | 213.244.2268 |
| Sunesys .....  | 951.278.0400 |
| Time Warner Communications.....                      | 951.549.3977 |
| Underground Service Alert .....                      | 800.227.2600 |
| United States Postal Service .....                   | 951.656.3240 |
| ValVerde Unified School District.....                | 951.940.6100 |
| Frontier.....  | 800.483.4000 |
| Waste Management.....                                | 800.423.9986 |
| Western Municipal Water District .....               | 951.789.5109 |

**5-8 SOUTHERN CALIFORNIA EDISON TEMPORARY ELECTRICAL SERVICE CONNECTION FOR CONSTRUCTION POWER**

The Contractor shall apply for and pay all charges levied by Southern California Edison for rendering temporary electrical service to this Project. Charges can be obtained by contacting Southern California Edison, 26100 Menifee Road, Romoland, California 92585, Telephone 951.928.8288. The foregoing address and telephone number are for informational assistance only and may not be accurate or complete.

## SECTION 6 – PROSECUTION, PROGRESS, AND ACCEPTANCE OF THE WORK

### 6-1 CONSTRUCTION SCHEDULE AND COMMENCEMENT OF WORK

#### 6.1.1 Construction Schedule

*Delete the first sentence of Subsection 6.1.1 and substitute the following:*

The Contractor shall submit a proposed construction schedule (Gant Chart) for the entire Work to the Engineer for review and approval five (5) Working Days prior to the pre-construction meeting and revised schedules thereafter as required by the Engineer when the Contractor's activities differ or are expected to differ from the latest existing schedule. If, on the date of commencement established in the Notice to Proceed, the Contractor has not submitted a construction schedule the Contractor will not be allowed to start Work and no extension of the Contract Time will be granted. The Contractor shall refer to the PROJECT SPECIFIC SCOPE OF WORK section in the Technical Provisions for any required or preferred sequence of Work.

*Add the following at the end of Subsection 6.1.1:*

The Contractor's Representative and the Contractor's principal subcontractors shall attend the Agency's pre-construction meeting. Other agencies and utilities involved in this Project may also have separate pre-construction meetings; the Contractor and applicable subcontractors are required to attend the agency/utility meetings.

#### 6-1.2 Commencement of the Work

*In the second sentence of Subsection 6-1.2, add the word "calendar" before the word "days."*

### 6-3 SUSPENSION OF THE WORK

#### 6-3.2 Archaeological and Paleontological Discoveries

*Add the following at the end of Subsection 6-3.2:*

During construction, if subsurface archaeological resources are encountered, they shall be left in place and a qualified archaeologist shall be called in to examine the findings. Work shall not resume, where discovery was made, until the archaeologist has reviewed the findings, made recommendations for their removal or preservation, and has a reasonable opportunity to carry out the necessary mitigation procedures. The Contract Time will be extended due to the discovery of subsurface archaeological resources only if the Contractor shows that there is no possible way to proceed with other Work items during the time Work was ceased pursuant to this Subsection of the Standard Specifications and the Special Provisions.

### 6-5 TERMINATION OF THE CONTRACT FOR CONVENIENCE

*Delete Subsection 6-5 in its entirety and substitute the following:*

#### 6-5.1 Termination for Cause

**6-5.1.1 Grounds.** The Agency shall have the right to terminate the Contractor's performance of the Work, in whole or in part, if:

- A. The Contractor fails to promptly commence the Work or unnecessarily or unreasonably delays the Work or improperly discontinues the prosecution of the Work or abandons the Work;
- B. The Contractor refuses or fails to supply skilled supervisory personnel, an adequate number of properly skilled workers, proper materials, or necessary equipment to perform the Work in strict accordance with the Contract Documents, and the latest approved construction schedule;
- C. The Contractor fails to make prompt payment of amounts properly due subcontractors after receiving payment from the Agency;
- D. The Contractor disregards Applicable Law, statutes, ordinances, codes, rules, regulations, or lawful orders of a public authority;
- E. The Contractor fails to resume performance of Work which has been suspended or stopped, within a reasonable time after receipt of notice from the Agency to do so or (if applicable) after cessation of the event preventing performance;
- F. Any representation or warranty made by the Contractor in the Contract Documents or any certificate, schedule, instrument, or other document delivered by the Contractor pursuant to the Contract Documents shall have been false or materially misleading when made;
- G. After commencement of the Work, the Agency becomes aware that the Contractor is using an ineligible contractor, subcontractor or supplier who was barred from performing Work or providing materials or services on Agency projects at the time of Bid;
- H. The Contractor fails to make payment to subcontractors for materials or labor in accordance with the respective Contract Documents and Applicable Law;
- I. The Contract is assigned or the Work is sublet otherwise than as specified in the Contract Documents;
- J. The Contractor otherwise is guilty of breach of a provision of the Contract Documents; or
- K. The Contractor materially fails to execute the Work in accordance with the Contract Documents or, in the Agency's opinion, is violating any of the terms of the Contract or is not executing the Contract in good faith or is not following instructions of the Agency as to additional force necessary in the opinion of the Agency for completion of the Work within the required time.

When the Agency terminates the Contractor's performance of the Work for one of the reasons stated in this Subsection 6-5.1.1 of the Special Provisions, the Contractor shall not be entitled to receive further payment until the Work is finished by others in accordance with Subsection 6-5.1.2 of the Special Provisions.

**6-5.1.2 Agency's Rights Upon Termination of Contract.** When any of the reasons specified in Subsection 6-5.1.1 of the Special Provisions exist, the Agency may, in addition to and without prejudice to any other rights or remedies of the Agency, notify the Contractor not to resume or to discontinue all Work, or any part thereof, by written notice of default. The Agency shall advise the Performance Bond surety of the notice of default and that they will be given **fifteen (15) Calendar Days** to arrange for completion of the Work in accordance with the Contract Documents by another contractor or contractors satisfactory to the Agency. Should the surety fail to effect satisfactory arrangements within said 15-day period, the Agency shall have the right to issue a notice of termination and to:

- A. Exclude the Contractor from the Project site;



- B. Take possession of the Project site and of all materials, equipment, tools and construction equipment, and machinery thereon owned by the Contractor;
- C. Suspend any further payments to the Contractor;
- D. Accept assignment of Subcontracts pursuant; and
- E. Finish the Work by whatever reasonable method the Agency may deem expedient.

**6-5.1.3 Cost of Completion of Work.** The Agency shall charge the cost to complete the Work, including, but not limited to, protection, investigation, labor, services, equipment, materials, permits, fees, supervisory and administrative costs to the Contractor and its Performance Bond surety. If the unpaid balance of the Contract Price exceeds costs of finishing the Work, including expenses and damages incurred by the Owner and not expressly waived, such excess shall be paid to the Contractor. If Agency's cost to complete the Work and damages incurred by Agency due to the Contractor's default exceed the unpaid Contract Price, the Contractor and its Performance Bond surety shall pay the difference to the Agency.

**6-5.1.4 Erroneous Termination.** If it has been adjudicated or otherwise determined that the Agency has erroneously or negligently terminated the Contractor for cause, then said termination shall automatically convert to a termination by the Agency for convenience as set forth in Subsection 6-5.2 of the Special Provisions.

**6-5.1.5 Acceptance of Incomplete or Non-Conforming Work.** In lieu of the provisions of Subsection 6-5 of the Special Provisions for terminating the Contractor's performance, Owner may pay the Contractor for the portion of Work completed according to the provisions of the Contract Documents and may treat the incomplete Work as if they had never been included or contemplated by this Contract, in which case the Contract Price will be reduced by the value of the deleted Work determined in accordance with Section 3, "Changes in Work," of the Standard Specifications and the Special Provisions. No Claim under this provision will be allowed the Contractor for overhead or prospective profits on Work not completed by the Contractor.

## **6-5.2 Termination for Convenience**

**6-5.2.1 Grounds.** The Agency may, at any time, terminate the Contractor's performance of the Work, in whole or in part, for the Agency's convenience without regard to the Contractor's fault or breach upon fourteen (14) Calendar Days' written notice to the Contractor.

**6-5.2.2 Immediate Contractor Action.** Upon receipt of written notice from the Agency of such termination for the Agency's convenience, the Contractor shall, unless the notice directs otherwise, do the following:

- A. Cease performance of the Work to the extent specified in the notice;
- B. Cooperate with the Agency to secure the site and demobilize in a safe and orderly fashion;
- C. Take actions necessary, or that the Agency may direct, for the protection and preservation of the Work;
- D. Except for Work directed to be performed in the notice, incur no further costs and enter into no further subcontracts and purchase orders;
- E. If requested by the Agency, assign to the Agency, in the manner and to the extent directed, all of the right, title and interest to the Contractor under the subcontracts, and the Agency shall have no liability for acts, omissions, or

- causes of action resulting therefrom which accrued prior to the date of termination and assignment, which liability shall remain with the Contractor; and
- F. Turn over to the Agency, as soon as possible, but not later than thirty (30) Calendar Days after receipt of such termination notice, the originals of all of the Contractor's records, files, documents, drawings, and any other items relating to the Project, whether located on the Project site, at the Contractor's office, or elsewhere.

**6-5.2.3 Waiver of Claims.** In the event that the Agency terminates the Contractor's performance of the Work for convenience, the Contractor agrees to waive any claims for damages, including, but not limited to, home office overhead, loss of anticipated profits on account thereof, and, as the sole right and remedy of the Contractor, the Agency shall pay the Contractor in accordance with Subsection 6-5.2.4 of the Special Provisions. The provisions of the Agreement, which by their nature survive Final Acceptance, shall remain in full force and effect after such termination to the extent provided in such provisions.

**6-5.2.4 Compensation.** Upon termination for convenience, the Contractor shall be entitled to be paid the full cost of all Work properly done by the Contractor prior to the date of termination not previously paid for, less sums already received by the Contractor on account of the portion of the Work satisfactorily performed, but in no event shall the amounts paid hereunder exceed the portion of Work completed in accordance with the Contract Documents. In no event shall the Contractor be entitled to recover any costs, overhead, or profit for Work not performed prior to the termination notice(s).

## 6-6 DELAYS AND EXTENSIONS OF TIME

### 6-6.1 General

*Delete Subsection 6-6.1 in its entirety and substitute the following:*

Work will not be allowed on days predicted by the South Coast Air Quality Management District (SAQMD) to be "Stage III" smog episode days. Notification will be given to the Contractor's Representative by the Engineer no later than 3:00 p.m. on the day preceding the predicted "Stage III" episode day. The Contractor will be entitled to an extension of Contract Time for such delays, but the Contractor will not be entitled to damages or additional payment due to such delays.

Work required to maintain the Project site in a safe condition (including but not limited to maintenance of traffic control), shall be allowed on **all** days.

**6-6.3.1 Excusable Non-Compensable Delay.** The Parties acknowledge that the following types of events are not within the responsibility or control of Agency or are reasonably contemplated by the Parties to occur during the course of performance of the Work, which may impact the schedule for performance of the Work and may entitle the Contractor to an extension of the Contract Time: (1) pulling of cables, energizing of the underground electrical system, and removal of overhead power lines and power poles by Southern California Edison, or any other contractor, on or adjacent to the Project site; and (2) "Force Majeure" events as defined herein ("Excusable Non-Compensable Delays"). "Force Majeure" means any of the following events, which materially and adversely affect the Contractor's obligations hereunder: earthquakes, acts of God, epidemic, blockade, embargoes, rebellion, war, terrorism, national emergency, riot, act of sabotage, civil commotion, industry-wide labor strike which has material adverse impact on

the Work, discovery of any archaeological, paleontological, or cultural resources, spill of hazardous substances by a third party at or near the Project site which is required to be reported to the California Environmental Protection Agency, Department of Toxic Substances Control, discovery at, near, or on the Project site of any species listed as "threatened" or "endangered" under the Federal or State Endangered Species Act, or unusually severe weather conditions.

An extension of the Contract Time shall be the Contractor's sole remedy of the Contractor for Excusable Non-Compensable Delays. In no event shall the Contractor be entitled to any compensation or recovery of any damages in connection with the Excusable Non-Compensable Delays defined above.

**6-6.3.2 Excusable Compensable Delay.** "Excusable Compensable Delay" means any delay to the Critical Path of the Work occurring after commencement and prior to completion of the Work: (1) which directly impacts the Contract Time established in the Agreement; (2) for which the Agency is responsible, is unreasonable under the circumstances involved and not within the contemplation of the Parties; and (3) is not due, in whole or in part, to the breach, negligence, or fault of the Contractor, or its subcontractors or suppliers. The Contractor's remedy for Excusable Compensable Delay shall be an extension of the Contract Time and reimbursement of actual costs directly resulting from such delays and markup established according to Subsection 3-3.2.3 of the Special Provisions.

**6-7 TIME OF COMPLETION**

**6-7.2 Working Day**

The term "Working Day" shall mean any Calendar Day except Saturdays, Sundays, and legal holidays observed at the locale of the Project. **City offices are open Monday through Thursday 7:30 a.m. to 5:30 p.m. and on Fridays 7:30 a.m. to 4:30 p.m.**

The following days have been designated as holidays by the City of Moreno Valley:

|                                   |                                    |
|-----------------------------------|------------------------------------|
| New Year's Day .....              | January 1                          |
| Martin Luther King, Jr. Day ..... | 3rd Monday in January              |
| President's Day .....             | 3rd Monday in February             |
| Memorial Day .....                | Last Monday in May                 |
| Independence Day .....            | July 4                             |
| Labor Day .....                   | 1st Monday in September            |
| Veterans' Day .....               | November 11                        |
| Thanksgiving .....                | 4 <sup>th</sup> Thurs. in November |
| Day after Thanksgiving .....      | 4th Friday in November             |
| Christmas Eve .....               | December 24                        |
| Christmas Day .....               | December 25                        |

If a holiday falls upon a Sunday, the following Monday shall be the day the holiday is observed, and if a holiday falls upon a Saturday, the preceding Friday shall be the day the holiday is observed.

### 6-7.3 Contract Time Accounting

*Add the following at the end of Subsection 6-7.3:*

The Contract Time for completion of the Work, including corrective items of Work, shall be in accordance with Section 5 of the Agreement. Contract Time extensions, when granted by the Engineer, will be in Working Days, will be in accordance with the Contract Documents, and will be set forth in writing via Change Order.

### 6-7.4 Work Outside Regular Hours

Work shall not be allowed outside of regular working hours (weekdays, 7:00 a.m. to 3:30 p.m., unless otherwise specified) without the advance approval of the Engineer, except Work items relating to maintenance and clean-up of the Work area for the purpose of public safety and convenience. The Contractor shall request such approval from the Engineer at least 48 hours (two Working Days) in advance of the proposed Work. The Contractor shall not fuel, grease, or otherwise service equipment or trucks from 7:00 p.m. to 6:00 a.m., Monday through Friday, and at no time on Sunday or holidays. Service work on equipment will be allowed on Saturday from 8:00 a.m. to 4:00 p.m.

Should Work outside of the above hours be approved, inspection, testing and construction engineering costs as a result of the Work outside of regular working hours shall be paid by the Contractor at the hourly rate, including fringe benefits, at straight time or time and one-half rates as applicable, or if a consultant inspection service is retained by the Agency, then the Contractor will reimburse the Agency for the actual cost. Under no circumstances will Work outside regular hours be allowed without full-time inspection.

## 6-8 COMPLETION, ACCEPTANCE, AND WARRANTY

### 6-8.1 Completion

*Add the following at the end of Subsection 6-8.1:*

“Completion” shall be understood to mean “Final Completion,” as defined in Subsection 1-2 of the Special Provisions.

### 6-8.2 Acceptance

*Add the following at the end of Subsection 6-8.2:*

“Acceptance” shall be understood to mean “Final Acceptance,” as defined in Subsection 1-2 of the Special Provisions.

### 6-8.3 Warranty

*Delete Subsection 6-8.3 in its entirety and substitute the following:*

The Contractor warrants to the Agency that materials and equipment furnished under the Contract will be of good quality and new unless the Contract Documents require or permit otherwise. The Contractor further warrants that the Work will conform to the requirements of the Contract Documents and will be free from defects, except for those inherent in the quality of the Work the Contract Documents require or permit. Work, materials, or equipment not conforming to these requirements, including “or equal” substitutions not properly approved and authorized, may be considered defective. The Contractor’s warranty excludes remedy for damage or defect caused by abuse, alterations to the Work not executed by the Contractor, improper or

insufficient maintenance, improper operation, or normal wear and tear and normal usage. If required by the Engineer, the Contractor shall furnish satisfactory evidence as to the kind and quality of materials and equipment. The Contractor's Performance Bond surety shall be liable for breaches of these warranties and the correction guarantees described herein.

In addition to the Contractor's obligations described above, if, within **one (1) year** after the date of Final Acceptance or designated portion thereof, or by terms of an applicable special warranty required by the Contract Documents, any of the Work is found to be not in accordance with the requirements of the Contract Documents, the Contractor shall, at its own expense, correct it promptly after receipt of written notice from the Agency to do. Such correction shall consist of making any repair or replacement necessary, including repair of settled backfill and resurfacing. In addition, the Contractor shall pay administrative costs related to inspection, testing, Contract administration, and attorneys' fees incurred to bring the Work to full compliance with the Contract Documents. If the Contractor fails to make such correction promptly, the Agency may, at its sole option, with its own or outside forces, correct the deficiencies. In such case, an appropriate Change Order or Construction Change Directive shall be issued deducting from payments then or thereafter due the Contractor the reasonable cost of correcting such deficiencies, including compensation for the additional services and expenses made necessary by the failure of the Contractor to correct the deficiencies. If payments then or thereafter due the Contractor are not sufficient to cover such amounts, the Agency shall invoice the Contractor for the difference and the Contractor shall pay the difference to the Agency, immediately.

During the one-year correction guarantee period, the Contractor shall act on all regular complaints within 48 hours and immediately for emergency repairs. The Owner will not be required to call subcontractors, suppliers, or manufacturers directly.

The one-year period for correction of Work shall be extended by corrective Work performed by the Contractor (i.e. the one-year correction period will re-start upon completion of corrective Work).

If, in the opinion of the Engineer, defective or non-conforming Work creates a dangerous condition or requires immediate correction or attention to prevent further loss to the Agency or to prevent interruption of operations of the Agency, the Agency will attempt to give the notice required by this Subsection of the Special Provisions. If the Contractor cannot be contacted or does not comply with the Engineer's request for correction within a reasonable time as determined by the Engineer, the Agency may, in accordance with this Subsection of the Special Provisions, proceed to make such correction or provide such attention, and the costs of such correction or attention shall be charged against the Contractor. Such action by the Agency will not relieve the Contractor of the guarantees provided in this Subsection of the Special Provisions or elsewhere in the Contract Documents.

This Subsection of the Special Provisions does not in any way limit the warranty on any items for which a longer warranty is specified or on any items for which a manufacturer gives a guarantee for a longer period. The Contractor shall furnish to the Agency all appropriate warranty or guarantee certificates, as required, upon completion of the Project.

Nothing contained in this Subsection of the Special Provisions shall be construed to establish a period of limitation with respect to other obligations the Contractor has under the Contract Documents. Establishment of the one-year period for correction of Work as described

in herein relates only to the specific obligation of the Contractor to correct the Work, and has no relationship to the time within which the obligation to comply with the Contract Documents may be sought to be enforced, nor to the time within which proceedings may be commenced to establish the Contractor's liability with respect to the Contractor's obligations other than specifically to correct the Work.

## SECTION 7 – RESPONSIBILITIES OF THE CONTRACTOR

### 7-1 THE CONTRACTOR’S EQUIPMENT AND FACILITIES

#### 7-1.1 General

*Add the following at the end of the first paragraph of Subsection 7-1.1:*

Such equipment and facilities shall meet all requirements of Applicable Law.

*Add the following at the end of the second paragraph of Subsection 7-1.1:*

The Contractor shall provide a hand washing facility. The Contractor shall comply with all Applicable Law pertaining to public health and sanitation.

#### 7-2.2 Prevailing Wages

##### 7-2.2.1 Determination of Prevailing Wage Rates

**7-2.2.1.1** The Agency has determined that the Contractor and subcontractors of any tier must pay not less than the prevailing wage rates to all workers employed in execution of the Contract. The Director of the Department of Industrial Relations, State of California (DIR) pursuant to the California Labor Code, has determined the general prevailing rates of wages in the locality in which the Work is to be performed. The Agency has obtained from the Director of the Department of Industrial Relations (DIR) pursuant to the Labor Code determinations of the generally prevailing rates of per diem wages and the prevailing rate for holiday and overtime work in the locality in which the Work is to be performed. Copies of said rates are on file with the Parks and Community Services Department of the City of Moreno Valley and will be made available for inspection during regular business hours and are also available on the Internet at the California Department of Industrial Relations website: <http://www.dir.ca.gov/dlsr/DPreWageDetermination.htm>. Future effective general prevailing wage rates, which have been predetermined and are on file with the California Department of Industrial Relations are referenced but not printed in the general prevailing wage rates.

**7-2.2.1.2** The wage rate for any classification not listed, but which may be required to execute the Work, shall be commensurate and in accord with specified rates for similar or comparable classifications for those performing similar or comparable duties. Holidays shall be as defined in the collective bargaining agreement applicable to each particular craft, classification, or type of worker employed under the Contract. Per diem wages include employer payments for health and welfare, pensions, vacation, travel time and subsistence pay, apprenticeship or other training programs authorized by California Labor Code § 3093, and similar purposes when the term “per diem wages” is used herein. Holiday and overtime work, when permitted by law, must be paid for at the rate of at least one and one-half (1½) times the above specified rate of per diem wages, unless otherwise specified. In accordance with Section 1773.2 of the California Labor Code, the Contractor must post a schedule showing all applicable prevailing wage rates at appropriate and conspicuous locations on the job site where they can easily be seen by workers.

**7-2.2.1.3** The Contractor is required to utilize apprentices as required by the California Labor Code and applicable regulations. Only apprentices, as defined in California Labor Code § 3077, who are in training under apprenticeship standards and written apprenticeship

agreements under California Labor Code § 3070 *et seq.* are eligible to be employed for the Work.

## **7-2.2.2 Payment of Prevailing Wage Rates**

### **7-2.2.2.1 Statutory Requirements**

The Project is subject to the provisions of Labor Code § 1720 *et seq.* and the requirements of Title 8 of the California Code of Regulations § 16000 *et seq.*, which govern the payment of prevailing wage rates on public works projects. The Contractor and subcontractors of any tier shall be governed by and required to comply with these statutes and regulations in connection with the Project. Pursuant to Labor Code § 1771, the Contractor and subcontractors of any tier must pay not less than the prevailing wage rates to all workers employed in execution of the Contract. The Contractor and all subcontractors must comply with all applicable statutes and regulations, including, but not limited to, Labor Code §§ 1771, 1775, 1777.5, 1813, and 1815.

### **7-2.2.2.2 Weekly Payments to Employees**

The Contractor and subcontractors of any tier must pay each worker on the Project, unconditionally and not less often than once each week, the full amounts that are due and payable for the period covered by the particular payday in accordance with the prevailing wage scale determination, regardless of any contractual relationship which may be alleged to exist between the Contractor, all subcontractor, and such laborers. Thus, an employer must establish a fixed workweek and an established payday. On each payday, each worker must receive all sums due at the end of the preceding workweek and must be provided with an itemized wage statement.

### **7-2.2.2.3 Classifications**

The Agency shall require that any class of laborers or mechanics, including apprentices and trainees, which are not listed in the General Wage Determinations and which are to be employed under this Contract, shall be classified conformably to such wage determinations. In the event the Agency does not concur in the Contractor's proposed classification or reclassification of a particular class of laborers and mechanics (including apprentices and trainees) to be used, the question, accompanied by the recommendation of the Agency, shall be referred to the State Director of Industrial Relations for determination.

### **7-2.2.2.4 Fringe Benefit Cash Equivalent**

The Agency shall require, whenever the minimum wage rate prescribed for a class of laborers or mechanics includes a fringe benefit which is not expressed as an hourly wage and the Contractor is obligated to pay a cash equivalent of such a fringe benefit, an hourly cash equivalent thereof must be established. In the event the interested parties cannot agree upon cash equivalent of the fringe benefit, the questions, accompanied by the recommendation of the Agency, shall be referred to the State Director of Industrial Relations for determination.



### **7-2.2.3 Penalty for Prevailing Wage Rate Underpayment**

Pursuant to Labor Code § 1775, the Contractor must, as a penalty, forfeit not more than Two Hundred Dollars (\$200.00) to the State or the Owner for each Calendar Day or portion thereof, for each worker paid less than the prevailing wage rates as determined by the Director of the Department of Industrial Relations for such work or craft in which such worker is employed for the Work by the Contractor or by subcontractors of any tier, in connection with the Work. The difference between prevailing wage rates and the amount paid to each worker each Calendar Day, or portion thereof, for which each worker paid less than the prevailing wage rate, must be paid to each worker by the Contractor.

### **7-2.2.4 Withholding**

The Agency shall upon its own action or upon written request of an authorized representative of the Department of Labor or DIR, withhold or cause to be withheld from the Contractor under this Contract so much of the accrued payments or advances as may be considered necessary to pay laborers and mechanics, including apprentices, trainees, and helpers, employed by the Contractor or any subcontractor the full amount of wages required by the Contract. In the event of failure to pay any laborer or mechanic, including any apprentice, trainee, or helper, employed or working on the site of the Work, all or part of the wages required by the Contract, the Agency may, after written notice to the Contractor, take such action as may be necessary to cause the suspension of any further payment, advance, or guarantee of funds until such violations have ceased.

### **7-2.2.5 Responsibility for Subcontractors' Payment of Prevailing Wages**

Pursuant to Labor Code § 1774, the Contractor is responsible for ensuring that subcontractors of any tier comply with requirements for payment of prevailing wages. The Contractor is responsible for Labor Code violations by subcontractors of any tier. The agreement executed between the Contractor and each subcontractor must contain a copy of the provisions of Labor Code §§ 1771, 1775, 1777.5, 1813, and 1815, at a minimum. The Contractor must monitor each subcontractor's payment of prevailing wage rates. Upon becoming aware of the failure of any subcontractor of any tier to pay its workers the specified prevailing wage, the Contractor must diligently take action to halt and rectify the failure, including, without limitation, retaining sufficient funds due to the subcontractor to cover the underpayment. Before making final payment to any subcontractor, the Contractor must obtain an affidavit from the subcontractor, signed under penalty of perjury, which states that the subcontractor has paid the specified, determined prevailing wage rate to its employees for the Project, as well as any amounts due pursuant to Labor Code § 1813. The Contractor must provide copies of such affidavits to the Owner and provide the Contractor's affidavit that it has paid the specified, determined prevailing wage rate to its employees for the Project, as well as any amounts due under Labor Code § 1813.

## **7-2.3 Payroll Records**

### **7-2.3.1 Certified Payroll Records and Basic Payroll Records**

The Contractor and Subcontractors of any tier must maintain Certified Payroll Records and "Basic Payroll Records," defined as time cards, front and back copies of canceled checks, cash receipts, trust fund forms, daily logs, employee sign-in sheets, accounting ledgers, tax

forms and/or any other record maintained for the purposes of reporting payroll, during the course of the Work and must preserve them for a period of **three (3) years** after completion of the Project for all tradeworkers executing the Work of the Contract. Certified Payroll Records must be submitted at the times designated in **Subsection 7-2.3.2** below or upon request as described in **Subsection 7-2.3.3** below. The Agency reserves the right to require the Contractor to routinely submit Basic Payroll Records may be requested by the Agency at any time and must be provided within **ten (10) Calendar Days** following the receipt of the request.

### **7-2.3.2 Submittal of Certified Payroll Records**

Pursuant to Labor Code § 1776, the Contractor and each subcontractor of any tier must maintain an accurate, weekly payroll record showing the employee full name, address, social security number, work classification, amount paid per hour, straight time, overtime and holiday hours worked each day and weekly totals, the actual per diem wages paid to each person employed for the Work, and the gross/net wages paid for this Project/all projects, as well as the Contractor name and address, Project name and location, and dates of payroll. If payments are made to any third party trust, funds or plans for health and welfare, pension or vacation trusts, those payments must be stated on the Certified Payroll Record. The basic wage rate paid per hour plus the employer contributions for benefits, including training fund contributions, must at least equal the prevailing wage rate for that classification.

The Contractor must maintain and submit one (1) copy of its Certified Payroll Records and those of its subcontractors weekly with the Contractor's application for payment. The Agency requires the Contractor to submit to the Agency each week, no later than seven (7) Calendar Days after the payday for the week covered, the Certified Payroll Records of the Contractor and its subcontractors of every tier. If there is no Work on a given week or on a given day, the Certified Payroll Record must indicate "no work" for that week or day(s). The Certified Payroll Records must account for each day of the week including Saturdays, Sundays and holidays. The Contractor and subcontractors of every tier must write "final" on the last submitted Certified Payroll Record for the Project.

The Certified Payroll Records must be verified by a written declaration made by a person with authority to represent the reporting entity, under penalty of perjury, that the information contained in the payroll record is true and correct and that the reporting entity has complied with the requirements of California Labor Code §§ 1771, 1811, and 1815 for any Work performed by his, her or its employees on the Project.

In addition, the Agency reserves the right to require the Contractor to provide monthly certified payroll records of local hiring and non-local hiring to ascertain local participation and shall allow the Agency and Agency's staff to conduct onsite visits upon request to ascertain local hiring participation.

The Contractor agrees that submission of Certified Payroll Records as well as all related or subsequent requests for supporting document made by the Agency shall be a condition precedent to the Contractor's receipt of a progress, final, or retention payment. The Agency shall withhold any portion of the progress, final, or retention payment up to and including the entire payment until the Certified Payroll Records requirement is met by the Contractor or its subcontractors. If the Contractor or any subcontractor is determined to have failed to pay workers in compliance with the applicable prevailing wage sections of the Labor Code, the

Agency shall continue to withhold progress, final, or retention payments until sufficient funds have been withheld for payment of wages to workers and all applicable penalties.

### 7-2.3.3 Making Certified Payroll Records Available Upon Request

Pursuant to Labor Code § 1776, in addition to its obligation to deliver certified payroll records to the Owner on a weekly basis as set forth above, the Contractor must also make payroll records available for inspection at all reasonable hours at the principal office of the Contractor on the following basis: (i) a certified copy of an employee's payroll record must be made available for inspection or furnished to such employee or his/her authorized representative on request; (ii) a certified copy of all payroll records must be made available for inspection or furnished upon request to the Owner, the Division of Labor Standards Enforcement and the Division of Apprenticeship Standards of the Department of Industrial Relations; (iii) a certified copy of payroll records must be made available upon request to the public for inspection or copies thereof made; provided, however, that a request by the public must be made through either the Agency, the Division of Apprenticeship Standards, or the Division of Labor Standards Enforcement. If the requested payroll records have not been previously provided to the Agency, the Division of Apprenticeship Standards or the Division of Labor Standards Enforcement, the requesting party must, prior to being provided the records, reimburse the cost of preparation by the Contractor, subcontractors and the entity through which the request was made; and the public may not be given access to such records at the principal office of the Contractor; (iv) the Contractor must file a certified copy of the payroll records with the entity that requested such records within **ten (10) Calendar Days** after receipt of a written request; and (v) any copy of records made available for inspection as copies and furnished upon request to the public or any public agency by the Agency, the Division of Apprenticeship Standards or the Division of Labor Standards Enforcement shall be marked or obliterated in such a manner as to prevent disclosure of an individual's name, address and social security number. The name and address of the Contractor or any subcontractor of any tier, performing a part of the Work must not be marked or obliterated. The Contractor must inform the Owner of the location of payroll records, including the street address, city and county and must, within **five (5) Working Days**, provide a notice of a change or location and address.

### 7-2.3.4 Forfeiture for Failure to Comply with Written Record Request Laws

The Contractor or all subcontractors shall have **ten (10) Calendar Days** in which to comply, subsequent to receipt of written request regarding Certified Payroll Records or Basic Payroll Records. In the event the Contractor or a subcontractor fails to strictly comply after such 10-day period, the Contractor or subcontractor shall, as a penalty to the State or the Owner, forfeit One Hundred Dollars (\$100.00) for each Calendar Day, or portion thereof, for each worker, until strict compliance is effectuated. Upon the request of the Division of Apprenticeship Standards or the Division of Labor Standards Enforcement, these penalties shall be withheld from any portion of the Contract Price then or thereafter due the Contractor. The Contractor is not subject to a penalty assessment pursuant to this paragraph due to the failure of a subcontractor to comply with this Subsection of the Special Provisions.

### 7-2.3.5 Statement of Employer Payments

Within **five (5) Calendar Days** of the Agency's request, the Statement of Employer Payments (**DSLE Form PW 26**) must be completed and submitted to the Agency by the Contractor and any subcontractor who pays benefits to a third party trust, plan or fund for health

and welfare benefits, vacation funds or makes pension contributions. The form must contain, for each worker classification, the fund or trust name, address, administrator, and amount per hour contributed and frequency of contributions. Training fund contributions must also be reported on this form. In February and August of each year during the Project, the Contractor and Subcontractors of any tier must verify changes in wage rates for any trade classifications used on the Project.

## **7-2.4 Hours of Labor**

### **7-2.4.1 Limits on Hours of Labor**

Pursuant to Labor Code § 1810, eight (8) hours of labor shall constitute a legal day's work. Pursuant to Labor Code § 1811, the time of service of any worker employed at any time by the Contractor or by a Subcontractor, of any tier, upon the Work or upon any part of the Work, is limited and restricted to eight (8) hours during any one Calendar Day and forty (40) hours during any one calendar week, except as hereafter provided. Notwithstanding the foregoing provisions, Work performed by employees of the Contractor or any Subcontractor, of any tier, in excess of eight (8) hours per day and forty (40) hours during any one week, shall be permitted upon compensation for all hours worked in excess of eight (8) hours per day at not less than one and one-half (1½) times the basic rate of pay.

### **7-2.4.2 Penalty for Excess Hours**

Pursuant to Labor Code §§ 1813 and 1815, the Contractor shall pay to the State or the Owner a penalty of Twenty-five Dollars (\$25.00) for each worker employed in the execution of the Contract by the Contractor or any Subcontractor, of any tier, for each Calendar Day during which such worker is required or permitted to work more than eight (8) hours in any Calendar Day and forty (40) hours in any one calendar week, in violation of the provisions of the California Labor Code, unless compensation to the worker so employed by the Contractor is not less than one and one-half (1½) times the basic rate of pay for all hours worked in excess of eight (8) hours per day.

### **7-2.4.3 Contractor Responsibility for Cost of Excess Hours**

Any Work performed by workers necessary to be performed after regular working hours or on Sundays or other holidays must be performed without adjustment to the Contract Price or any other additional expense to the Agency.

## **7-2.5 Apprentices**

### **7-2.5.1 Apprenticeship Committee Contract Award Information**

Pursuant to Labor Code § 1777.5 and Title 8 California Code of Regulations § 230, the Contractor and Subcontractors of any tier who are not already approved to train by an apprenticeship program sponsor must, within ten (10) Calendar Days of signing the Contract or Subcontract, as applicable, but in any event prior to the first day in which the Contractor has workers employed on the Project, must submit contract award information. This information may be submitted on a Public Works Contract Award Information form (DAS form 140). The contract award information must be provided to the appropriate local apprenticeship committees

whose geographic area of operation include the area of the Project and can supply apprentices to the Project.

### 7-2.5.2 Employment of Apprentices

Labor Code § 1777.5 and Title 8 California Code of Regulations § 200 *et seq.* provide detailed requirements for employing apprentices on public works. The responsibility of complying with Section 1777.5 and the regulations lies exclusively with the Contractor. When the Contractor or Subcontractor employs workers in any Apprenticeable Craft or Trade, the Contractor and Subcontractor must employ apprentices in at least the ratio set forth in Labor Code Section 1777.5.

Every apprentice employed to perform any of the Work must be paid the prevailing rate of per diem wages for apprentices in the trade to which such apprentice is registered, and such individual must be employed only for the work of the craft or trade to which such individual is registered.

Only apprentices, as defined in Labor Code § 3077, who are in training under apprenticeship standards and written apprenticeship agreements under California Labor Code § 3070 *et seq.* are eligible to be employed for the Work. The employment and training of each apprentice shall be in accordance with either of the following:

- a. The apprenticeship standards and apprentice agreements under which such apprentice is training; or
- b. The rules and regulations of the California Apprenticeship Council, including regulations Section 230.1(c), which requires that apprentices employed on public projects can only be assigned to perform work of the craft or trade to which the apprentice is registered and that the apprentices must at all times work with or under the direct supervision of journeyman/men.

### 7-2.5.3 Apprenticeship Certificate and Request for Dispatch of Apprentices

- a. When the Contractor or any Subcontractor of any tier in performing any of the Work employs workers in any Apprenticeable Craft or Trade, as defined in **Subsection 7-2.5.4** below, the Contractor and such Subcontractor may apply to the Joint Apprenticeship Committee administering the apprenticeship standards of the craft or trade in the area of the site of the Work for a certificate approving the Contractor or such Subcontractor under the apprenticeship standards for the employment and training of apprentices in the area or industry affected, provided, however, that the approval as established by the Joint Apprenticeship Committee or Committees shall be subject to the approval of the Administrator of Apprenticeship. The Joint Apprenticeship Committee or Committees, subsequent to approving the Contractor or Subcontractor, shall arrange for the dispatch of apprentices to the Contractor or such Subcontractor in order to comply with California Labor Code § 1777.5. There shall be an affirmative duty upon the Joint Apprenticeship Committee or Committees, administering the

apprenticeship standards of the crafts or trades in the area of the site of the Work, to ensure equal employment and affirmative action and apprenticeship for women and minorities. Contractors or Subcontractors shall not be required to submit individual applications for approval to local Joint Apprenticeship Committees provided they are already covered by the local apprenticeship standards.

- b. Contractors who are not already approved to train apprentices must request dispatch of required apprentices from one of the applicable Apprentices Committees whose geographic area of operation includes the site of the Project by giving the committee actual notice of at least forty-eight (48) hours (excluding Saturdays, Sundays and holidays) before the date on which one or more apprentices are required. Contractors and Subcontractors may use **DAS form 142** to make the request for apprentices. However, if a non-signatory contractor declines to abide by and comply with the terms of a local committee's standards, the Apprenticeship Committee shall not be required to dispatch apprentices to such contractor. Conversely, if in response to a written request, an Apprenticeship Committee does not dispatch any apprentice to a contractor who has agreed to employ and train apprentices in accordance with either the Apprenticeship Committee's Standards or the California Apprenticeship Counsel Regulations (Title 8, Section 230 *et seq.*) within 72 hours of such request (excluding Saturdays, Sundays and holidays) the Contractor shall not be considered in violation of Section 230.1 as a result of failure to employ apprentices for the remainder of the Project, provided the Contractor has made the request in enough time to meet the required ratio. If an Apprenticeship Committee dispatches fewer apprentices than the Contractor or Subcontractor requested, the Contractor or Subcontractor shall be considered in compliance if the Contractor employs those apprentices who are dispatched, provided that, where there is more than one Apprenticeship Committee able and willing to unconditionally dispatch apprentices, a contractor or Subcontractor who is not a participant in an apprenticeship program has requested dispatch from at least two committees.

#### 7-2.5.4 Ratio of Apprentices to Journeymen

- a. The ratio of Work performed by apprentices to journeymen, who shall be employed in the Work, may be the ratio stipulated in the apprenticeship standards under which the Joint Apprenticeship Committee operates, but in no case shall the ratio be less than one hour of apprentice work for every five hours of labor performed by a journeyman, except as otherwise provided in California Labor Code § 1777.5. The ratio of apprentice work to journeyman work shall apply during any day or portion of a day when any journeyman is employed at the site of the Work and shall be computed on the basis of the hours worked during the day by journeymen so employed. Any Work performed by a journeyman in excess of eight hours per day or 40 hours per week shall not be used to calculate the ratio. The Contractor must employ apprentices for the number of hours computed as above before the end of the Contract or subcontract, as

applicable. The Contractor must, however, endeavor, to the greatest extent possible, to employ apprentices during the same time period that the journeymen in the same craft or trade are employed at the site of the Work. Where an hourly apprenticeship ratio is not feasible for a particular craft or trade, the Division of Apprenticeship Standards, upon application of a Joint Apprenticeship Committee, may order a minimum ratio of not less than one apprentice for each five journeymen in a craft or trade classification.

- b. The Contractor or any Subcontractor covered by this Paragraph and California Labor Code § 1777.5, that has agreed to be covered by an Apprenticeship Program's standards, upon the issuance of the approval certificate, or that has been previously approved in such craft or trade, must employ the number of apprentices or the ratio of apprentices to journeymen stipulated in the apprenticeship standards, but in no event less than the 1-to-5 hourly ratio. Upon proper showing by the Contractor that it employs apprentices in such craft or trade in the State of California on all of its contracts on an annual average of not less than one apprentice to each five journeymen, the Division of Apprenticeship Standards may grant a certificate exempting the Contractor from the 1-to-5 hourly ratio as set forth in this Paragraph and California Labor Code § 1777.5.

#### 7-2.5.5 Exemption

The requirement to employ apprentices shall not apply to contracts of general contractors, or to contracts of specialty contractors not bidding for work through a general or prime contractor, involving less than Thirty Thousand Dollars (\$30,000.00) or **twenty (20) Working Days**. The term "Apprenticeable Craft or Trade," as used herein shall mean a craft or trade determined as an Apprenticeable occupation in accordance with rules and regulations prescribed by the Apprenticeship Council.

#### 7-2.5.6 Contributions to Trust Funds

The Contractor or any Subcontractor of any tier who performs any of the Work by employment of journeymen or apprentices in any Apprenticeable Craft or Trade shall contribute to the California Apprenticeship Council in the same amount that the Director determines is the prevailing amount of apprenticeship training contributions in the area of the Project. The Contractor or any Subcontractor, of any tier, may take as a credit for payments to the Council any amounts paid by the Contractor or Subcontractor to an approved apprenticeship program that can supply apprentices to the Project. Contractors who do not contribute to an apprenticeship program must submit their contributions to the California Apprenticeship Council. Training Fund contributions are due and payable on the 15th day of the month for work performed during the preceding month. Training contributions to the California Apprenticeship Council shall be paid by check and shall be accompanied by a **Completed Training Fund Contribution form (CAC-2)**. Contractors who contribute to an apprenticeship program are entitled to a full credit in the amount of those contributions. The Division of Labor Standards Enforcement is authorized to enforce the payment of such contributions to such fund(s) as set forth in California Labor Code §227. Such contributions shall not result in an increase in the Contract Price.

### 7-2.5.7 Contractor's Compliance

The responsibility of compliance with this Subsection of the Special Provisions for all Apprenticeship Trades or Crafts is solely and exclusively that of the Contractor. All decisions of the Joint Apprenticeship Committee(s) under this Subsection of the Special Provisions are subject to the provisions of California Labor Code § 3081. In the event the Contractor willfully fails to comply with the provisions of this Paragraph and California Labor Code § 1777.5, pursuant to California Labor Code § 1777.7, the Contractor shall: (i) be denied the right to bid on any public works contract for a period of one (1) year from the date the determination of noncompliance is made by the Administrator of Apprenticeship; and (ii) forfeit, as a civil penalty, One Hundred Dollars (\$100.00) for each Calendar Day of noncompliance. Notwithstanding the provisions of California Labor Code § 1727, upon receipt of such determination, the Agency shall withhold such amount from the Contract Price then due or to become due. Any such determination shall be issued after a full investigation, a fair and impartial hearing, and reasonable notice thereof in accordance with reasonable rules and procedures prescribed by the California Apprenticeship Council. Any funds withheld by the Agency pursuant to this Paragraph shall be deposited in the fund that funded the Project unless otherwise specified by the Engineer. The interpretation and enforcement of California Labor Code §§ 1777.5 and 1777.7 shall be in accordance with the rules and procedures of the California Apprenticeship Council.

### 7-2.6 Employment of Minors

The Contractor shall not employ or engage any minor less than 16 years of age for the purpose of building or construction work of any kind (Title 8 CAC 11701, LC 1294). When minors between 16 and 18 years of age are employed or engaged in building or construction work, the Contractor must obtain permits to work and permits to employ minors from school authorities in the school district in which the minor resides or attends school (ED 49110 to 49113, 49131, & 49160). Any contractor that hires a minor of 16 years of age or older who is a high school graduate or who has been awarded a certificate of proficiency is exempt from the permit requirements (ED 49101).

The Contractor shall keep on file all permits to work and permits to employ, records showing the names, ages (dates of birth) and address of all minors employed, along with payroll records for at least three years (ED 49161, LC 1174, 1175, 1299). The minors' records are to be open at all times for inspection by school attendance officers, members of the Industrial Welfare Commission, and designees, probation officers, officers of the Superintendent at Public Instruction, and officers of the Division of Labor Standards Enforcement (ED 49164, 49181, LC 1174, 1299). The Contractor shall submit to the Agency a copy of Permits to Work and Permits to Employ or proof of graduation or certificate of proficiency before any minor is allowed to work.

Failure to comply with the provisions of the child labor laws may cause the imposition of criminal and civil sanctions.

### 7-2.7 Labor Nondiscrimination

Pursuant to Labor Code Section 1735, no discrimination shall be made in the employment of persons upon public works because of the race, religious creed, color, national origin, ancestry, physical disability, mental disability, medical condition, marital status, or sex of



such persons, except as provided in Section 12940 of the Government Code, and every contractor for public works violating Labor Code Section 1735 is subject to all the penalties imposed for a violation of Division 2, Part 7, Chapter 1 of the Labor Code.

**7-2.7.1** During the performance of this Contract, the Contractor and its Subcontractors shall not unlawfully discriminate against any employee or applicant for employment because of race, religion, color, national origin, ancestry, physical disability, mental disability, medical condition, marital status, age (over 40) or sex. Contractors and Subcontractors shall ensure that the evaluation and treatment of their employees and applicants for employment are free of such discrimination. Contractors and Subcontractors shall comply with the provisions of the California Fair Employment and Housing Act (CGC 12900 et seq.) and the applicable regulations promulgated thereunder (California Code of Regulations, Title 2, Section 7285.0 et seq.). The applicable regulations of the Fair Employment and Housing Commission implementing Government Code Section 12990, set forth in Title 2, Division 4, Chapter 5 of the California Code of Regulations are incorporated into this Contract by reference and made a part hereof as if set forth in full. The Contractor and its Subcontractors shall give written notice of their obligations under this clause to labor organizations with which they have a collective bargaining or other agreement.

**7-2.7.2** The Contractor shall include the nondiscrimination and compliance provisions of Subsection 7-2.5 of the Special Provisions in all subcontracts to perform Work under the Contract.

**7-2.7.3** These provisions are applicable to all Contractors and Subcontractors having a construction Contract or subcontract of \$5,000 or more:

- 1. As used herein:
  - a. "Administrator" means Administrator, Office of Compliance Programs, California Department of Fair Employment and Housing, or any person to whom the Administrator delegates authority;
  - b. "Minority" includes:
    - i. Black (all persons having primary origins in any of the black racial groups of Africa, but not of Hispanic origin);
    - ii. Hispanic (all persons of primary culture or origin in Mexico, Puerto Rico, Cuba, Central or South America or other Spanish derived culture or origin regardless of race);
    - iii. Asian/Pacific Islander (all persons having primary origins in any of the original peoples of the Far East, Southeast Asia, the Indian Subcontinent or the Pacific Islands); and
    - iv. American Indian/Alaskan Native (all persons having primary origins in any of the original peoples of North America and who maintain culture identification through tribal affiliation or community recognition).
- 2. Whenever the Contractor or any Subcontractor subcontracts a portion of the Work, it shall physically include in each subcontract of \$5,000 or more, the nondiscrimination clause in this Contract directly or through incorporation by reference.

3. The Contractor shall implement the specific nondiscrimination standards provided in paragraph 6(a) through (e) of this Subsection of the Special Provisions.
4. Neither the provisions of any collective bargaining agreement, nor the failure by a union with whom the Contractor has a collective bargaining agreement, to refer either minorities or women, shall excuse the Contractor's obligations under this Subsection of the Special Provisions, Government Code Section 12990, or the regulations promulgated pursuant thereto.
5. In order for the nonworking training hours of apprentices and trainees to be counted, such apprentices and trainees must be employed by the Contractor during the training period, and the Contractor must have made a commitment to employ the apprentices and trainees at the completion of their training, subject to the availability of employment opportunities. Trainees must be trained pursuant to training programs approved by the U.S. Department of Labor or the California Department of Industrial Relations.
6. The Contractor shall take specific actions to implement its nondiscrimination program. The evaluation of the Contractor's compliance with this Subsection of the Special Provisions shall be based upon its effort to achieve maximum results from its actions. The Contractor must be able to demonstrate fully its efforts under steps (a) through (e) below.
  - a. Ensure and maintain a working environment free of harassment, intimidation, and coercion at all sites, and at all facilities at which the Contractor's employees are assigned to work. The Contractor shall specifically ensure that all foremen, superintendents, and other on-site supervisory personnel are aware of and carry out the Contractor's obligations to maintain such a working environment, with specific attention to minority or female individuals working at such sites or in such facilities.
  - b. Provide written notification within seven days to the director of DFEH when the union or unions with which the Contractor has a collective bargaining agreement has not referred to the Contractor a minority person or woman sent by the Contractor, or when the Contractor has other information that the union referral process has impeded the Contractor's efforts to meet its obligations.
  - c. Disseminate the Contractor's equal employment opportunity policy by providing notice of the policy to unions and training, recruitment, and outreach programs and requesting their cooperation in assisting the Contractor to meet its obligations; and by posting the company policy on bulletin boards accessible to all employees at each location where construction work is performed.
  - d. Ensure all personnel making management and employment decisions regarding hiring, assignment, layoff, termination, conditions of work,

training, rates of pay or other employment decisions, including all supervisory personnel, superintendents, general foremen, on-site foremen, etc., are aware of the Contractor's Equal Employment Opportunity Policy and obligations, and discharge their responsibilities accordingly.

- e. Ensure that seniority practices, job classifications, work assignments and other personnel practices, do not have a discriminatory effect by continually monitoring all personnel and employment related activities, to ensure that the equal employment related activities, the employment opportunity policy, and the Contractor's obligations under these Specifications are being carried out.
7. Contractors are encouraged to participate in voluntary associations that assist in fulfilling their equal employment opportunity obligations. The efforts of a Contractor association, joint contractor-union, contractor-community, or other similar group of which the Contractor is a member and participant, may be asserted as fulfilling any one or more of its obligations under this Subsection of the Special Provisions provided that the Contractor actively participates in the group, makes every effort to assure that the group has a positive impact on the employment of minorities and women in the industry, ensures that the concrete benefits of the program are reflected in the Contractor's minority and female workforce participation, and can provide access to documentation which demonstrates the effectiveness of actions taken on behalf of the Contractor. The obligation to comply, however, is the Contractor's.
  8. The Contractor is required to provide equal employment opportunities for all minority groups, both male and female, and all women, both minority and non-minority. Consequently, the Contractor may be in violation of the Fair Employment and Housing Act (CGC Section 12900 et seq.) if a particular group is employed in a substantially disparate manner.
  9. Establishment and implementation of a bona fide Affirmative Action Plan pursuant to Title 2 California Code of Regulations Section 8104(b) shall create a rebuttal presumption that a contractor is in compliance with the requirements of Government Code Section 12990 and its implementing regulations.
  10. The Contractor shall not use the nondiscrimination standards to discriminate against any person because of race, color, religion, sex, national origin, ancestry, physical disability, mental disability, medical condition, marital status, or age over 40.
  11. The Contractor shall not enter into any subcontract with any person or firm decertified from state Contracts pursuant to Government Code Section 12990.
  12. The Contractor shall carry out such sanctions and penalties for violation of this Subsection of the Special Provisions and the nondiscrimination clause, including suspension, termination and cancellation of existing subcontracts as may be imposed or ordered pursuant to Government Code Section 12990, and its implementing regulations by the awarding agency. Any contractor who fails to

carry out such sanctions and penalties shall be in violation of this Subsection of the Special Provisions and Government Code Section 12900.

13. The Contractor shall designate a responsible official to monitor all employment related activity to ensure that the company's equal employment opportunity policy is being carried out, to submit reports relating to the Provisions hereof as may be required by OCP and to keep records. Records shall at least include for each employee the name, address, telephone numbers, construction trade, union affiliation, if any, employee identification number when assigned, social security number, race, sex, status, (e.g., mechanic, apprentice trainee, helper, or laborer), dates of changes in status, hours worked per week in the indicated trade, rate of pay, and locations at which the work was performed. Records shall be maintained in any easily understandable and retrievable form; however, to the degree that existing records satisfy this requirement, the Contractor shall not be required to maintain separate records.

### **7-2.8 Posting of Signs**

The Contractor shall display the Project Identification Sign, the federal (if applicable) and state wage rate information, the "Equal Employment Opportunity is the Law" poster, and other required posters in a visible location at the Project site. The signs and posters shall be mounted in an acceptable manner and constructed as specified.

### **7-3 INSURANCE**

*Delete Subsection 7-3 in its entirety.*

#### **7-3.2 General Liability Insurance**

*See Paragraph 7 of the Agreement for insurance requirements.*

#### **7-3.34 Workers' Compensation Insurance**

*See Paragraph 7 of the Agreement for insurance requirements.*

### **7-5 PERMITS**

*Delete Subsection 7-5 in its entirety and substitute the following:*

Work shall not be started until the Contractor has obtained all necessary licenses and permits. The Contractor shall obtain and pay for all permits and give all notices necessary and incident to the due and lawful prosecution of the Work and to the preservation of the public health and safety. Unless otherwise indicated within these Special Provisions, fees will not be collected on those permits issued by the Agency for Agency-owned projects; some exceptions include Temporary Use Permit, City Business Licenses, etc. It is the responsibility of the Contractor to verify required permits and responsibility of payment therefor prior to Bid submittal.

#### **7.5.1 Trench and Excavation Permits**

Excavation shall not be started on any trench, vertical or sloping, that is five feet (5') or more in depth until the Contractor has obtained a permit from the State Division of Industrial Safety and submitted a copy of said permit to the Engineer (LC 6500). Upon demand by the

Agency or the State Division of Industrial Safety or representatives thereof, the Contractor shall produce the permit.

**7-5.2 National Pollutant**

The Contractor shall provide National Pollutant Discharge Elimination System (NPDES) permit training for Urban Runoff management to the Contractor’s employees and Subcontractors, if any. Each day that the Contractor fails to provide Urban Runoff management training is a violation of the current version of the Regional Water Quality Control Board Order, and a breach of the Contract with the Agency. The Contractor understands and agrees that NPDES permit violations are grounds for enforcement action by the Environmental Protection Agency, the State/Regional Water Resources Control Board, and the Agency, and may result in permit termination (stop work order), civil and criminal fines, and termination of the Contract. By submitting a Bid, the Contractor certifies to the Agency that it has trained its employees and Subcontractors, if any, for Urban Runoff management and included sufficient sums in the Bid Price to cover such costs of said training.

The Contractor is responsible for all clean up and payment of all fines levied as a result of any illegal discharge (as defined in the NPDES Permit) occurring as a result of the Contractor’s Work and/or operations.

**7-5.3 Right of Entry**

The Agency shall provide any required rights of entry at no cost to the Contractor for Work on private property that is shown on the Plans. Such rights of entry do not relieve the Contractor of the need to provide, at its own cost, permits and insurance required of the Contractor by other agencies and organizations.

**7-5.4 Licenses**

The Contractor and Subcontractors shall obtain and incur all costs for licenses necessitated by their operations. The Contractor and all Subcontractors shall obtain and keep current a City of Moreno Valley Business License prior to commencement and throughout the duration of their Work.

**7-6 THE CONTRACTOR’S REPRESENTATIVE**

*Add the following at the end of Subsection 7-6:*

On a daily basis, the Contractor’s Representative (or designated alternate) shall provide the Engineer a list of all labor, equipment, and materials used, and a summary of Work performed on the Project that day. The Contractor shall provide this information by the end of the Working Day to the Agency Inspector. If this information is not provided, the Agency will not process the Contractor’s monthly progress payment.

The Contractor’s Representative (or designated alternate) shall be present at the Project site at all times that Work is in progress. Work by Subcontractors will not be allowed in the absence of the Contractor’s Representative (or designated alternate), unless previous arrangements are approved by the Engineer in writing. In the event a Subcontractor attempts to perform Work in the absence of the Contractor’s Representative (or designated alternate), a STOP WORK NOTICE will be issued to the Subcontractor.

When Work is not in progress and during periods when Work is suspended, arrangements acceptable to the Engineer shall be made for any emergency Work that may be required.

## **7-8 WORK SITE MAINTENANCE**

### **7-8.1 General**

*Delete the second paragraph of Subsection 7-8.1 and substitute the following:*

Materials spilled along or on streets, roads, any public right of way, parking areas, or private property shall be removed completely and promptly.

When and as often as required by the Engineer, the Contractor shall furnish and operate self-loading motorized street sweeper equipped with a functional water spray system, to keep paved areas affected by the work clean and dust free. If the sweeper fails to keep the paved areas clean and dust free then the Contractor shall provide additional sweepers or stop the Work until the paved areas are clean and dust free. The use of water resulting in mud on paved areas will not be permitted.

*Add the following at the end of Subsection 7-8.1:*

All clean-up costs shall be included in the various related items of Work and no additional compensation will be allowed as a result of suspension of Work for failure to comply with clean up orders.

Waste Management of the Inland Empire, a division of Waste Management, Inc. (Tel: 951.280.5400) has an exclusive franchise with the City of Moreno Valley for the collection, transportation, recycling, composting, and disposal of solid waste, green waste, special waste, and construction and demolition waste and for providing temporary bin/roll-off services for all commercial and residential premises within the Agency, pursuant to Moreno Valley Municipal Code Chapter 6.02, "Refuse Collection, Transfer and Disposal."

### **7-8.4.2 Storage in Public Streets**

*Delete the first paragraph of Subsection 7-8.4.2 and substitute the following:*

Construction materials, stockpile and equipment shall not be stored in streets, roads, parking areas or any public right of way unless otherwise specified in the Special Provisions or approved by the Engineer. All materials or equipment not installed or used in construction shall be stored at a location approved by the Engineer. All stockpile and storage areas shall be kept in a safe, neat, clean, and orderly fashion, and shall be restored to equal or better than original condition upon completion of work.

### **7-8.6.4 Dewatering**

*Add the following at the end of Subsection 7-8.6.4:*

The Contractor shall maintain drainage within and through the Work areas.

### 7-8.7 Flood Hazards and Dry Weather Flow

Special attention is directed to possible flood hazards and nuisance water such as irrigation and other runoff. The Contractor shall be responsible for all personal injuries and for all damages to any portion of the Work occasioned by the above causes and the Contractor shall make good such injuries or damages at no cost to the Agency prior to Final Acceptance.

### 7-8.8 Vermin Control

At the time of Final Acceptance, structures entirely constructed under the Contract shall be free of rodents, insects, vermin, and pests. Necessary extermination work shall be arranged and paid for by the Contractor as part of the Work within the Contract Time and Contract Price, and shall be performed by a licensed exterminator in accordance with requirements of Applicable Law. The Contractor shall be liable for injury to persons or property and responsible for the elimination of offensive odors resulting from exterminating operations.

### 7-8.9 Protection of the Work

The Contractor shall protect all Work, materials, and equipment from damage from any cause whatsoever, and shall provide adequate and proper storage facilities during the progress of the Work. The Contractor shall provide for the safety and good condition of all Work until Final Acceptance by the Agency, and shall replace all damaged or defective Work, materials, and equipment before requesting Final Acceptance.

The Contractor is and shall be held responsible for the protection and correction of the Work of all trades from smears, splashes, stains, or damages that might occur during the progress of the Work.

The Contractor shall remove graffiti from all Work, materials, equipment, and signs within the project. Equipment, materials, or signs containing graffiti shall not be brought to the Project. Any graffiti found on Work, materials, equipment, or signs shall be cleaned or removed from the Project within 24 hours after discovery. The cost of graffiti removal shall be borne by the Contractor as part of the Contract Price.

### 7-8.10 Solid Waste Disposal and Recycling Report

The Contractor shall complete monthly Solid Waste Disposal and Recycling Reports and submit them to the Agency, as outlined in the Solid Waste Disposal and Recycling Report – Instructions (see Appendix). The cost of the reports shall be borne by the Contractor as part of the Contract Price.

## 7-9 PROTECTION AND RESTORATION OF EXISTING IMPROVEMENTS

*Add the following at the end of Subsection 7-9:*

Damaged traffic signal loop detectors must be replaced within seventy two (72) hours.

**7-10 SAFETY**

**7-10.1 Street Closures, Detours, and Barricades**

*Rename Subsection 7-10.1 and include the following:*

Street closures are usually not allowed on City streets, and may be specifically prohibited as stipulated in the Contract Documents. Otherwise, the Contractor may request full street closure consideration from the Engineer. The Contractor shall submit a request for street closure to the Engineer. The Engineer may route the request through the various City departments for approval consideration. Once there is approval from all necessary departments, the matter will be brought before the City Council for approval consideration. The estimated time frame for department and City Council consideration is approximately six (6) weeks from the time the request is received. The Contractor shall notify the Police, Fire, and Public Works Departments of, or serving, the City of Moreno Valley at least 48 hours in advance of closing, or partially closing, or of reopening, any street, alley, or other public thoroughfare, and shall comply with the requirements of said departments in respect thereto. If the telephone numbers herein below are changed, the Contractor is not relieved of the responsibility of notifying said departments.

The following telephone numbers are listed to assist the Contractors in compliance with these requirements:

|   |               |
|---|---------------|
| Fire Department .....                         | Emergency 911 |
| Business.....                                 | 951.486.6784  |
| Police Department .....                       | Emergency 911 |
| Business.....                                 | 951.486.6700  |
| Parks and Community Services Department ..... | 951.413.3280  |
| Parks Projects.....                           | 951.413.3163  |
| Parks Maintenance .....                       | 951.413.3703  |
| Public Works Department .....                 | 951.413.3100  |
| Transportation Engineering .....              | 951.413.3140  |
| Maintenance & Operations .....                | 951.413.3160  |
| Capital Projects.....                         | 951.413.3130  |
| Land Development.....                         | 951.413.3120  |
| Moreno Valley Utility .....                   | 951.413.3500  |

In any site affected by peak hour traffic flows, no lane closure shall be allowed before 8:30 a.m. or after 4:00 p.m. unless approved in writing by the Engineer.

**7-10.2 Traffic Controls**

*Rename Subsection 7-10.2 and include the following:*

Traffic controls, including, but not limited to, vehicular and pedestrian traffic controls, maintenance of vehicular and pedestrian access, detours, and street closures shall be in accordance with the Special Provisions; Traffic Control Plans; California MUTCD, latest edition at the time of bid; "Work Area Traffic Control Handbook"(WATCH – latest edition at the time of bid); and Section 7-10, "Safety" and Part 6, "Temporary Traffic Control" of the latest edition of the "Greenbook," Standard Specifications for Public Works Construction, including all supplement amendments, in effect and published at the Bid Deadline. Nothing in the Special



Provisions shall be construed as relieving the Contractor from his or her responsibility to provide for the safety and convenience of traffic and the public during construction.

In the event of conflict, the order of precedence shall be as follows:

1. Special Provisions
2. Traffic Control Plans
3. California MUTCD
4. Work Area Traffic Control Handbook (WATCH)
5. Standard Specifications

Whenever vehicles or equipment are parked on the shoulder of a roadway within six feet (6') of a traffic lane, the shoulder area shall be closed with fluorescent traffic cones or portable delineators placed on a taper in advance of the parked vehicles or equipment, and along the edge of the pavement at twenty-five foot (25') intervals to a point not less than twenty-five feet (25') past the last vehicle or piece of equipment. A minimum of nine (9) cones or portable delineators shall be used for the taper. A W20-1 (Road Work) or W21-5b (Shoulder Work) sign shall be mounted on a telescoping flag tree with flags.

The Contractor shall install temporary railing (Type K-Modified) between any lane carrying public traffic and any excavation, obstacle, or storage area when the following conditions exist:

1. Excavations – Any excavation the near edge of which is twelve feet (12') or less from the edge of the lane, except:
  - a. Excavations covered with sheet steel or concrete covers of adequate thickness to prevent accidental entry by traffic or the public.
  - b. Excavations less than one foot deep.
  - c. Trenches less than one foot wide for irrigation pipe or electrical conduit or excavations less than one foot in diameter.
  - d. Excavations parallel to the lane for the purpose of pavement widening or reconstruction.
  - e. Excavations in side slopes, where the slope is less steep or equal to 4:1.
  - f. Excavations protected by existing barrier or railing.
2. Temporarily Unprotected Permanent Obstacles – Whenever the Work includes the installation of a fixed obstacle together with a protective system, such as a sign structure together with protective railing, and the Contractor elects to install the obstacle prior to installing the protective system; or whenever the Contractor, for his convenience and with permission of the Engineer, removes a portion of an existing protective railing at an obstacle and does not replace such railing complete in place during the same day.
3. Storage Areas – Whenever material or equipment is stored within twelve feet (12') of the lane and such storage is not otherwise prohibited by the Specifications.

### 7-10.2.1 Traffic Control Plan

The Contractor shall submit a Traffic Control Plan signed by a Traffic Engineer to the City of Moreno Valley at or prior to the pre-construction meeting for approval by the Transportation Engineering Division.

### 7-10.3 Haul Routes

*Delete Subsection 7-10.3 and substitute the following:*

Unless otherwise specified in the Special Provisions, haul routes shall conform to City-established truck routes, or as approved by the Traffic Engineer.

### 7-10.4 Safety

#### 7-10.4.2 Safety Orders

*Add the following at the end of Subsection 7-10.4.2:*

Federal and State laws have established occupational safety and health standards with which all employers must comply. These laws require an employer to provide a safe place of employment (i.e., one that is reasonably free from danger to life or health).

The California Division of Industrial Safety (Cal/OSHA) issues citations if, during an inspection, it observes an employee exposed to an unsafe or unsanitary condition. Citations may also be issued when employee exposure can be shown to have occurred even though not observed during an inspection. Every citation will identify the violation and the gravity of the violation (serious, general, or regulatory).

In addition to the authority to issue citations, Cal/OSHA has the authority to prohibit entry into an unsafe area and the use of unsafe equipment when an imminent hazard exists (LC 6325). A violation of this type of order is a misdemeanor.

When an actual exposure cannot be demonstrated but a condition is found to exist that would be a violation if an exposure were to occur, then Cal/OSHA may issue an "Information Memorandum." To allow an employee to be exposed to a condition identified in an Information Memorandum constitutes a willful violation of the Safety Orders.

Should a contractor receive a citation, shut-down (yellow tag), or an Information Memorandum, the Contractor shall notify the Engineer of such.

#### 7-10.4.2.2 Shoring Plan

*Add the following at the end of Subsection 7-10.4.2.2*

The Contractor shall comply with all applicable requirements of Labor Code Section 6705, and no requirements of that Section shall be construed to impose tort liability on the Agency or on any employee or officer of the Agency.

#### 7-10.4.4 Hazardous Substances

*Add the following at the end of Subsection 7-10.4.4*

The Contractor shall take precautions not to spill or contaminate an area with hazardous material. Materials found to be hazardous substances pursuant to the Hazardous Substances Information and Training Act (Labor Code Section 6360 et seq.), such as epoxy resins, motor oils, and petroleum derivatives, shall be disposed of properly. If any hazardous material is spilled or contaminates an area, the Contractor shall notify the Riverside County Department of Health, Environmental Health Division, and have the spill or contaminated area cleaned up at the Contractor's expense. The hazardous materials shall be disposed of in accordance with the laws governing said material at a State or United States Environmental Protection Agency approved treatment, storage or disposal facility, or recycling facility. The Contractor shall give the Agency a copy of the Uniform Hazardous Waste Manifest promptly after disposition of the hazardous material. This provision shall not be construed to affect or limit any other liability, duty, or responsibility of the Contractor or other person with regard to safeguarding the health and safety of employees and other persons exposed to a toxic or hazardous material.

Any Work which involves digging trenches or other excavations that extend deeper than four feet (4') below the surface where discovery of hazardous waste or other unusual conditions may have an effect on the Work, the procedures shall be as follows:

1. The Contractor shall promptly, and before the following conditions are disturbed, notify the Agency in writing of any:
  - a. Material that the Contractor believes may be material that is hazardous waste, as defined in Section 25117 of the Health and Safety Code, which is required to be removed to a Class I, Class II, or Class III disposal site in accordance with provisions of existing law.
  - b. Subsurface or latent physical conditions at the site differing from those indicated.
  - c. Unknown physical conditions at the site of any unusual nature, different materially from those ordinarily encountered and generally recognized as inherent in work of the character provided for in the contract.
2. The Agency shall promptly investigate the conditions, and if it finds that the conditions do materially so differ, or do involve hazardous waste, and cause a decrease or increase in the Contractor's cost of, or the time required for, performance of any part of the Work shall issue a Change Order pursuant to Section 3 "Changes in Work" of the General Provisions.
3. That, in the event that a dispute arises between the public entity and the Contractor whether the conditions materially differ, or involve hazardous waste, or cause a decrease or increase in the Contractor's cost of, or time required for, performance of any part of the Work, the Contractor shall not be excused from any scheduled completion date provided by the Contract, but shall proceed with all the Work to be performed under the Contract. The Contractor shall retain any and all rights provided either by

Contract or by law which pertain to the resolution of disputes and protests between the contracting parties (PCC 7104).

**7-10.4.6 Emergency Phone Numbers**

The following emergency phone numbers are listed for the convenience of the Contractor to assist in complying with these requirements:

The Contractor shall keep a list of emergency phone numbers on the Project site. Whenever more than ten (10) employees are on the Project site at any time, said list shall be posted on a bulletin board, to be supplied and installed on the Project site by the Contractor, at his expense, in a location visible and accessible to all employees.

|  |                        |
|--|------------------------|
| Ambulance Services.....  | 911                    |
| Box Springs Mutual Water Company .....                                 | 951.653.6419           |
| City of Moreno Valley <b>Fire Department</b> .....                     | 911 or 951.486.6784    |
| City of Moreno Valley <b>Police Department</b> .....                   | 911 or 951.486.6700    |
| Parks and Community Services Department .....                          | 951.413.3280           |
| Parks Projects.....  | 951.413.3163           |
| Parks Maintenance.....   | 951.413.3703           |
| City of Moreno Valley, Public Works Department .....                   | 951.413.3100           |
| City of Moreno Valley, PW Operations & Facilities .....                | 951.413.3160           |
| Eastern Municipal Water District (Integrated Operations Center) .....  | 951.928.3777 ext. 6265 |
| Edgemont Community Services District (Albert A. Webb & Assoc.) .....   | 951.686.1070           |
| Moreno Valley Community Hospital .....                                 | 951.243.0811           |
| 27300 Iris Avenue, Moreno Valley<br>(2 miles east of Perris Boulevard) |                        |
| Moreno Valley Unified School District .....                            | 951.485.5600 ext. 3775 |
| Moreno Valley Utilities (Electrical) .....                             | 877.811.1888           |
| Questar Southern Trails.....   | 714.379.3376           |
| 5762 Bolsa Avenue, Suite 201<br>Huntington Beach, CA 92649             |                        |
| Riverside County Regional Medical Center .....                         | 951.486.4000           |
| 26520 Cactus Avenue<br>(South of HWY 60)                               |                        |
| Riverside Medical Clinic.....  | 951.683.6370           |
| 6405 Day Street<br>(South of HWY 60, Riverside, CA)                    |                        |
| Riverside Transit Agency.....  | 951.684.0850           |
| SBC (formerly Pacific Bell) .....                                      | 800.750.2355           |
| Southern California Edison Company .....                               | 800.611.1911           |
| Southern California Gas Company (Distribution).....                    | 909.335.3919           |
| Southern California Gas Company (Transmission) .....                   | 213.244.2268           |
| Sunesys .....  | 951.278.0400           |
| Time Warner Communications .....                                       | 951.549.3977           |
| Underground Service Alert .....  | 800.227.2600           |
| United States Postal Service .....                                     | 951.656.3240           |
| Val Verde Unified School District.....                                 | 951.940.6100           |
| Valley Medical Group.....  | 951.242.9594           |
| 24490 Sunnymead Blvd., Moreno Valley                                   |                        |

|   |              |
|---|--------------|
| Frontier .....  | 800.483.4000 |
| Waste Management.....                                     | 800.423.9986 |
| Western Municipal Water District (answering service)..... | 951.789.2960 |

The Agency does not warrant the completeness or accuracy of the list or the numbers.

**7-10.4.7 Safety Responsibility**

The Contractor shall be solely and completely responsible for the condition of the premises on which the Work is performed and for the safety of all persons and property on the site during performance of the Work. This requirement shall not be limited to normal working hours, but shall apply continuously.

The Contractor shall provide the Engineer with the Contractor's Injury and Illness Prevention Program and a site program five (5) Working Days before the pre-construction meeting. The Injury and Illness Prevention Program shall include the name and telephone number of the Project Safety Manager or Officer.

The Contractor shall correct all unsafe conditions immediately. The Engineer shall use the following guidelines when an unsafe condition is identified:

- 1. Imminent Hazard – a condition that if not corrected would most likely result in an accident causing severe or permanently disabling injury or death.

When an Imminent Hazard is known to exist or when the Contractor either delays in correcting or permits repeated occurrences of an Imminent Hazard, the Engineer shall immediately order the Contractor verbally and in writing to suspend the operations affected and not permit the Work to resume until the Imminent Hazard has been corrected. The Contractor shall remove all personnel not necessary to make the corrections. The local Division of Industrial Safety office will be notified of the Imminent Hazard and of the action taken.

- 2. Dangerous Condition (Serious Hazard) – a condition that does not present an immediate danger to workers or the public, but if not corrected, could result in a disabling injury and possible death, or could develop into an Imminent Hazard.

When a Dangerous Condition is known to exist, the Engineer shall notify the Contractor verbally and in writing of the conditions and allow a reasonable period for correcting the Dangerous Condition. The Contractor shall remove all personnel not necessary to make the corrections. If the Engineer is not certain of the remedial measures proposed or taken by the Contractor, then the Agency or Caltrans construction safety coordinator shall be consulted. If the Contractor does not correct the Dangerous Condition or if the condition is deteriorating into an Imminent Hazard, the Engineer shall suspend the affected operations and the local Division of Industrial Safety office will be notified.

- 3. Minor or Non-Serious Condition – condition that could result in minor or less serious injuries, or that are repetitive in nature or that may be classified as a threat to health.

When a Minor or Non-Serious Condition is known to exist, the Engineer shall advise the Contractor verbally and in writing of the condition and of the necessity for eliminating it. If the Contractor fails to correct the problem or permits its repeated occurrence on subsequent operations, the Engineer shall suspend the affected operations.

The Contractor will not be allowed any additional compensation or extension of time for operations suspended due to unsafe conditions.

The Contractor shall immediately notify the City and document any observed defects or hazardous conditions in the vicinity of the Project site prior to, during, and after Project construction.

**7-13 LAWS TO BE OBSERVED**

*Add the following at the end of Subsection 7-13:*

If the Contractor observes that any portions of the Contract Documents are at variance with Applicable Law, the Contractor shall promptly notify the Engineer in writing by RFI. If the Contractor performs any Work when the Contractor knows or should have reasonably known it would be contrary to Applicable Law, the Contractor shall assume full responsibility therefor and shall bear all risks and costs (without adjustment to the Contract Price) directly or indirectly attributable to the correction of the Work. If the Contractor fails to comply with Applicable Law, the City may (without prejudice to any of its other rights and remedies) issue an order suspending all or any part of the Work. If the Contractor is prevented, in any manner, from strict compliance with the Contract Documents due, directly or indirectly, to Applicable Law, the Contractor shall immediately notify the Engineer.

**7-15 OWNER-OPERATOR LISTING**

The Contractor and Subcontractors shall list all owner-operators on the project and certify owner-operator status by providing at least the following information:

1. Operator name as shown on all payrolls.
2. Business address of the owner-operator.
3. The owner-operator’s social security number.
4. The truck/tractor license number, California identification truck number, weight, and number of axels. If equipment is used, the Contractor must provide a complete description of the equipment, make, model number, and include the dates the equipment was operated on the project.
5. Operator labor classification.
6. Hours worked by the owner-operator as reported on a daily basis.
7. Hourly rental rate paid for the owner-operator equipment.
8. Actual payments earned.

This information must be provided by the Contractor on the California Department of Transportation “Owner-Operator Listing” and “Owner-Operator Listing Statement of Compliance” forms, available online at <http://www.dot.ca.gov/hq/construc/forms/cem2505.pdf>. Certification will be accepted only from the Contractor or Subcontractor employing the owner-operator. The City will not accept certified payrolls or an Owner-Operator Listing directly from the owner-operator unless that owner-operator is a licensed contractor and is also an approved

Subcontractor or recognized lower tier sub-subcontractor. The Contractor shall submit the "Owner-Operator Listing Statement of Compliance" form weekly to the City, beginning within ten (10) Calendar Days after end of the first week worked. If there is a temporary break in the Work, then the Contractor shall submit an Owner-Operator Listing marked "no Work performed." When the owner-operator is no longer needed, then the word "final" shall be placed above the name of the owner-operator.

The information shown on the Owner-Operator Listing will be used to determine the hourly wage rate due by deducting the prevailing equipment rental rate as set forth in the California Department of Transportation publication entitled "Labor Surcharge and Equipment Rental Rates" from the gross hourly rate shown on the owner-operator listing (without mark-up). The determined hourly wage will be compared to the prevailing wage rate, plus fringe benefits, for the applicable craft or classification determine compliance.

The following factors are considered when determining whether an owner-operator is an independent contractor or an employee of the Contractor:

1. If review of payroll records show that deductions for social security taxes or State unemployment insurance taxes are withheld for the owner-operator, it is an indication that the operator is an employee rather than an independent contractor.
2. An employee interview of the owner-operator indicates that the owner-operator is in fact an employee.
3. Truck owner-operators should be the registered owner of the vehicle. The name of the driver should match the name of the registered owner on the Department of Motor Vehicle's registration.
4. If the legal owner is a firm or corporation, and the firm or corporation name is shown on the vehicle registration slip, the driver shall furnish evidence that they are leasing or purchasing the vehicle. If the owner-operator is unable to substantiate purchase or lease of the equipment, the City will disallow use of the owner-operator classification for this truck. Insurance for the vehicle shall be carried in the driver's name. The California identification (CA) number issued by the California Highway Patrol (CHP) shall be in the driver's name.
5. If the equipment owner-operator owns, is leasing, or financing the equipment other than a truck, then the operator shall furnish such evidence. If the owner-operator is unable to substantiate that they own, are purchasing, or leasing the equipment, the Engineer will disallow use of the owner-operator classification for the equipment. The Contractor must establish proof of ownership in cases where there is doubt as to the validity of the owner-operator designation.

## 7-16 EMPLOYEE INTERVIEW

The Contractor and Subcontractors shall make available all employees and owner operators for labor compliance interviews during work hours. Labor compliance interviews will

be conducted by the Engineer or the California Department of Industrial Relations. The interview shall be conducted on the Work site at a place and for a duration that will permit privacy for the employee and cause the least amount of disruption to the ongoing Work. The Contractor's Representative shall not be present during the interview.

**7-17 RECORD DRAWINGS**

At the beginning of the Project, one bond copy or blueline print of each applicable Drawing will be issued by the Agency to the Contractor for use in preparing Record Drawings (also called "red line As Built Drawings").

Actual construction conditions shall be accurately and completely recorded on the bond copy or blueline prints as the Project progresses. The Contractor shall update the Record Drawings daily and review the Record Drawings with the Inspector weekly. If the Contractor fails to update Record Drawings, the monthly progress payment will not be processed until the Inspector is satisfied that the Record Drawings have been updated for the month the Contractor is requesting a progress payment. Upon completion of the Work, the Contractor shall sign the Record Drawings and shall submit same to the Agency's Inspector for review and approval. The 5% retention will not be released to the Contractor until the Record Drawings have been submitted to the Agency and approved. If the Contractor has not submitted an accurate copy of the Record Drawings within 30 Calendar Days after completion of the Work, the Agency reserves the right to have the Record Drawings prepared and to deduct all applicable costs incurred from the retention amount.

**7-18 RIGHTS IN LAND AND IMPROVEMENTS**

Nothing in the Specifications shall be construed to allow the Contractor to make any arrangement with any person to permit occupancy or use of any land, structure, or building within the Project site for any purpose whatsoever, either with or without compensation, in conflict with any agreement between the Agency and any owner, former owner, or tenant of the land, structure, or building.

The street right-of-way shall be used only for purposes that are necessary to perform the Work. The Contractor shall not occupy the right-of-way, or allow others to occupy the right-of-way, for purposes that are not necessary to perform the Work.

The Contractor shall secure at its own expense any area required for plant sites, storage of equipment or materials, or for other purposes if sufficient area is not available to the Contractor within the Contract limits, or at the sites designated on the plans outside the Contract limits.

For the aforementioned uses on private or public property (outside the public right-of-way), the Contractor shall apply for a temporary use permit (TUP) from the City's Planning Division. The Contractor shall not have use of the area until the TUP has been issued. Fees for the TUP will be the responsibility of the Contractor.

The Agency shall provide any required rights of entry at no cost to the Contractor for Work on private property that is shown on the Plans. Such rights of entry do not relieve the Contractor of the need to provide, at its own cost, permits and insurance required of the Contractor by other agencies and organizations.

Attachment: SPECIAL PROVISIONS - MVCP SKATE PARK (3355) : APPROVE AND EXECUTE AGREEMENT WITH MICON CONSTRUCTION FOR



## SECTION 8 – FACILITIES FOR AGENCY PERSONNEL

Field office facilities for Agency Personnel will not be required on this project.

## SECTION 9 – MEASUREMENT AND PAYMENT

### 9-1 MEASUREMENT OF QUANTITIES FOR UNIT PRICE OF WORK

#### 9-1.1 General

*Add the following at the end of Subsection 9-1.1:*

All items of Work which are not designated on the Bid Schedule by the letters "F" or "LS" or words "Final" or "Lump Sum" shall have final pay quantities measured and paid for in accordance with the Standard Specifications and Special Provisions.

### 9-2 LUMP SUM WORK

*Delete the first sentence of Subsection 9-2 and substitute the following:*

Items of Work which are designated by the letters "LS" or the words "Lump Sum" in the Estimated Quantities column of the Bid Schedule shall be paid for at the price indicated in the Bid, unless the dimensions of said Work, as shown on the Plans, are revised by the Engineer. If such dimensions are revised and such revisions result in an increase or decrease in the quantity of such Work, the final payment for said lump sum item will be revised in proportion to the change in dimensions authorized by Change Order.

*Add the following at the end of Subsection 9-2:*

The Contractor shall submit a Work item breakdown of the Bid, described in the second paragraph of Subsection 9-2, "Lump Sum Work," of the Standard Specifications, within 15 Calendar Days after award of Contract and/or at any other time as required by the Engineer.

No guarantee is made regarding the amount of Work required to complete a lump sum item of Work.

#### 9-2.1 Progress Payments for Lump Sum Items of Work

The word "Complete" in the Estimated Quantities column of the Bid Schedule for a lump sum item of Work shall mean that payment for that item will only be made after all Work for that item has been completed. The "%" symbol in the Estimated Quantities column of the Bid Schedule for a lump sum item of Work shall mean that progress payments for that item will be allowed based on the percentage of completion as determined by the Engineer in each pay period, typically every 30 days (see Subsection 9-3.2 of the Standard Specifications and the Special Provisions).

### 9-3 PAYMENT

#### 9-3.1 General

*Delete the first sentence of Subsection 9-3.1 and substitute the following:*

For unit items of Work, the estimated quantities listed on the Bid Schedule will not govern the final payment.

Delete the eighth paragraph of Subsection 9-3.1 and substitute the following:

Warranty periods shall be in accordance with Subsection 6-8, "Warranty of Work and Materials," of the Special Provisions.

Add the following at the end of the ninth paragraph of Subsection 9-3.1:

In the event that a stop payment notice is filed with the Agency, an amount equal to 125% of the total of the amount claimed in the stop payment notice will be withheld by the Agency until the stop payment notice has been released. Alternatively, the Contractor may file with the Agency a bond, on a form approved by the Agency, executed by one or more corporate California Admitted surety insurers, in an amount equal to one hundred and twenty-five percent (125%) of the claim stated in the stop payment notice conditioned for the payment of any sum which the stop payment notice claimant may recover on the claim together with its costs of suit in the action. Upon the Agency's acceptance of such bond, the Agency shall not withhold money from the Contractor on account of the stop payment notice. The surety(ies) upon the stop payment notice release bond shall be different than, and jointly and severally liable to the stop payment notice claimant with, the Payment Bond surety(ies). A stop payment notice is not effective unless given before the expiration of whichever of the following time periods is applicable: (1) If a notice of completion, acceptance, or cessation is recorded, 30 days after the recordation; (2) If a notice of completion, acceptance, or cessation is not recorded, 90 days after cessation or completion.

Delete the tenth paragraph of Subsection 9-3.1 and substitute the following:

Not later than sixty (60) days from the date of Final Acceptance, the five percent (5%) deducted and retained from each progress estimate (see Subsection 9-3.2 of the Standard Specifications and the Special Provisions) by the Agency will be paid to the Contractor except such amounts as are required by law to be withheld by properly executed and filed notices to stop payment, or as may be authorized by the Contract to be further retained.

The Contractor understands that Final Acceptance does not generally occur for one to two (1-2) weeks after Final Completion. Final Completion is the stage of performance of the Work when:

1. All Work required by the Contract Documents has been fully completed in compliance with the Contract Documents and all Applicable Laws including, but not limited to, correction or completion of all punch list items; and
2. The Contractor has delivered to the Agency all closeout documentation required by the Contract Documents, including, but not limited to:
  - a. Duly completed and executed forms of Conditional Waiver and Release Upon Final Payment and Declaration to Procure Final Payment from the Contractor, Subcontractors of any tier, suppliers, and other persons eligible to file stop notices in connection with the Work, covering the final payment period;

- b. Duly completed and executed forms of Unconditional Waiver and Release Upon Final Payment and Declaration to Procure Final Payment from the Contractor, Subcontractors of any tier, suppliers, and other persons eligible to file stop notices in connection with the Work, covering the previous payment period;
- c. Record Drawings / As-Built Drawings;
- d. Consent of surety(ies) to final payment;
- e. Special warranties, if applicable;
- f. Operation and maintenance manuals and/or training manuals, if applicable; and
- g. Any other documentation required by the Specifications.

### 9-3.1.1 Final Pay Quantities

When the estimated quantities for a specific portion of the Work are designated on the Bid Schedule as final pay quantities with the letter "F" or the word "Final," said estimated quantities shall be the actual quantities for which payment for such specific portion of the Work will be made, unless the dimensions of said portions of the Work shown on the Plans are revised by the Engineer. If such dimensions are revised and such revisions result in an increase or decrease in the quantities of such Work, the final quantities for payment will be revised in the amount represented by the changes in the dimensions authorized by Change Order.

The estimated quantities designated on the Bid Schedule with the letter "F" or the word "Final," are approximations only, and no guarantee is made that the quantities which can be determined by computations based on the details and dimensions shown on the Plans will equal the estimated quantities. No adjustment in the Contract Price will be made in the event that quantities based on subsequent computations or measurements do not equal the estimated final pay quantities.

### 9-3.2 Partial and Final Payment

*Delete the first, second, third, and fourth paragraphs of Subsection 9-3.2 and substitute the following:*

Except as otherwise provided in Subsection 9-2.1 "Progress Payments for Lump Sum Items of Work," of the Special Provisions, the Contractor will be entitled to no more than one progress payment per month. Thirty (30) Calendar Days prior and as a condition to each progress payment, the Contractor shall submit to the Engineer a detailed estimate and invoice of the total quantity and value of Work completed since the cut-off date for the previous progress payment. The Engineer shall make the final determination as to the actual quantity and value of Work completed for which payment will be made. From each progress payment, **five percent (5%)** will be deducted and retained by the Owner until Final Payment is made in accordance with Subsection 9-3.1 of the Standard Specifications and the Special Provisions; the remainder, less the amounts needed to satisfy outstanding stop notices, will be paid to the Contractor.

No progress payment to the Contractor or its sureties will constitute a waiver of the liquidated damages specified in the Agreement. Liquidated damages, if any, will be deducted from earned progress payments due the Contractor.

This Contract is subject to the following provisions of California Public Contract Code Section 20104.50 which provides as follows:

- a. (1) It is the intent of the Legislature in enacting Subsection 9-3.2 of the Standard Specifications and the Special Provisions to require all local governments to pay their contractors on time so that these contractors can meet their own obligations. In requiring prompt payment by all local governments, the Legislature hereby finds and declares that the prompt payment of outstanding receipts is not merely a municipal affair, but is, instead, a matter of statewide concern.
 

(2) It is the intent of the Legislature in enacting this article to fully occupy the field of public policy relating to the prompt payment of local governments' outstanding receipts. The Legislature finds and declares that all governmental officials, including those in local government, must set a standard of prompt payment that any business in the private sector that may contract for services should look toward for guidance.
- b. Any local agency which fails to make any progress payment within thirty (30) days after receipt of an undisputed and properly submitted payment request from the Contractor or construction Contract shall pay interest to the Contractor equivalent to the legal rate set forth in subdivision (a) of § 685.010 of the Code of Civil Procedure.
- c. Upon receipt of a payment request, each local agency shall act in accordance with both of the following:
  - (1) Each payment request shall be reviewed by the local agency as soon as practicable after receipt of the purpose of determining that the payment request is a proper payment request;
  - (2) Any payment request determined not to be a proper payment request suitable for payment shall be returned to the Contractor as soon as practicable, but not later than seven (7) days, after receipt. A request returned pursuant to this Subsection of the Standard Specifications and the Special Provisions shall be accompanied by a document setting forth in writing the reasons why the payment request is not proper.
- d. The number of days available to a local agency to make a payment without incurring interest pursuant to this Subsection of the Standard Specifications and the Special Provisions shall be reduced by the number of days by which a local agency exceeds the seven-day return requirement set forth in paragraph (2) of subdivision (c), above.
- e. For purposes of this Article:

(1) A "local agency" includes, but is not limited to, a city, including a charter city, a county, and a city and county, and is any public entity subject to this part.

(2) A "progress payment" includes all payments due contractors, except that portion of the final payment designated by the Contract as retention earnings.

(3) A payment request shall be considered properly executed if funds are available for payment of the payment request, and the Financial Officer of the local agency does not delay the payment due to an audit inquiry.

f. Each local agency shall require that this article, or a summary thereof, be set forth in the terms of any Contract subject to this article.

*Add the following to the end of the fifth paragraph of Subsection 9-3.2:*

At the request and sole expense of the Contractor, securities equivalent to the amount withheld shall be deposited with the City, or with a state or federally chartered bank in California as escrow agent, who shall pay such monies to the Contractor after satisfactory completion of the Contract. Securities eligible for investment under this Subsection of the Standard Specifications and the Special Provisions shall include those listed in Section 16430 of the Government Code, bank or savings and loan certificates of deposit, interest-bearing demand deposit accounts, and standby letters of credit. The Contractor shall be the beneficial owner of any securities substituted for monies withheld and shall receive any dividends and interest thereon. Alternatively, the Contractor may request that the Agency, at the expense of the Contractor, make payment of retention earned directly to the escrow agent. Notwithstanding the foregoing, such contractor shall have thirty (30) Calendar Days following award of the Contract to submit a written request to the Agency to permit the substitution of securities for retention or payment to an escrow agent; failure to do so shall be deemed a waiver of the right. If the Contractor requests such substitution or payment to escrow, the Agency, the Contractor, and escrow agent shall execute a separate agreement regarding such substitution or payment to escrow.

See Subsection 9-3.1 of the Standard Specifications and the Special Provisions regarding timing of Final Payment.

**9-3.3 Delivered Materials**

*Delete Subsection 9-3.3 in its entirety and substitute the following:*

Unless included in the Bid Schedule, or unless otherwise called for in these Special Provisions, no payment will be made for materials or equipment delivered but not incorporated in the Work.

**9-4 PROMPT PROGRESS PAYMENT TO SUBCONTRACTORS**

The Contractor's attention is directed to Business and Professions Code Sections 7108.5 and 7108.6 concerning prompt payment to Subcontractors and transportation charges submitted by dump truck drivers. The Contractor shall pay all Subcontractors for and on account of Work performed by such Subcontractors within seven (7) Calendar Days after receipt of progress payment from the Agency and within seven (7) Calendar Days after receipt of retention from the Agency. The Contractor shall pay all transportation charges submitted by a

duly authorized motor carrier of property in dump truck equipment by the 20th day following the last day of the calendar month in which the transportation was performed, if the charges, including all necessary documentation, are submitted by the fifth day following the last day of the calendar month in which the transportation was performed.

If there is a good faith dispute over all or any portion of the amount due on a progress payment from the Contractor to a Subcontractor or dump truck driver, the Contractor may withhold no more than one hundred and fifty percent (150%) of the disputed amount.

## **9-5 RETENTION WITHHELD FROM SUBCONTRACTORS**

**9-5.1** This Contract is subject to the following provisions of Public Contract Code Section 7200, which provides as follows:

- A. Subsection 9-5 of the Special Provisions shall apply with respect to all Contracts entered into on or after January 1, 1999, between a public entity and an original contractor, between an original contractor and a Subcontractor, and between all Subcontractors thereunder, relating to the construction of any public Work of improvement.
- B. For purposes of Subsection 9-5 of the Special Provisions, "public entity" means the state, including every state agency, office, department, division, bureau, board, or commission, a city, county, city and county, including chartered cities and chartered counties, district, special district, public authority, political subdivision, public corporation, or nonprofit transit corporation wholly owned by a public agency and formed to carry out the purposes of the public agency.
- C. In a Contract between the original contractor and a Subcontractor, and in a Contract between a Subcontractor and any Subcontractor thereunder, the percentage of the retention proceeds withheld may not exceed the percentage specified in the Contract between the public entity and the original contractor.
- D. When a performance and payment bond is required in the solicitation for bids, item (C) above shall not apply to either of the following:
  - 1. The original contractor, if the Subcontractor fails or refuses to provide a performance and payment bond issued by an admitted surety insurer, to the original contractor.
  - 2. The Subcontractor, if a Subcontractor thereunder fails or refuses to provide a performance and payment bond issued by an admitted surety insurer, to the Subcontractor.
- E. No party identified in item (C) above shall require any other party to waive any provision of Subsection 9-5 of the Special Provisions.
- F. In the event that the Contractor elects to substitute securities in lieu of retentions, the Contractor may withhold from its Subcontractors, who have not elected to substitute securities in lieu of retentions, the amount of retentions that would have otherwise been withheld.

## AGENCY SPECIAL PROVISIONS

### PART 2

#### TECHNICAL PROVISIONS 0702

Refer to Technical Specifications listed below at end of the Special Provisions

#### MORENO VALLEY COMMUNITY PARK – SKATE PARK IMPROVEMENTS

#### TABLE OF CONTENTS:

|                    |  |
|--------------------|--|
| <b>DIVISION 1</b>  | <b>GENERAL REQUIREMENTS</b>            |
| 01000              | MOBILIZATION                           |
| 01300              | SUBMITTALS                             |
| <br>               |  |
| <b>DIVISION 2</b>  | <b>SITE CONSTRUCTION</b>               |
| 02100              | SITE DEMOLITION                        |
| 02210              | SITE GRADING                           |
| 02441              | IRRIGATION                             |
| 02470              | SITE FURNISHINGS                       |
| 02441              | IRRIGATION                             |
| 02800              | PLANTING                               |
| <br>               |  |
| <b>DIVISION 3</b>  | <b>CONCRETE</b>                        |
| 03100              | CONCRETE FORMWORK                      |
| 03300              | CONCRETE REINFORCEMENT                 |
| 03300              | CONCRETE                               |
| 03 10 00           | CONCRETE FORMING FOR SKATEPARKS        |
| 03 12 00           | EARTH MOVING FOR SKATEPARKS            |
| 03 20 00           | CONCRETE REINFORCING FOR SKATEPARKS    |
| 03 30 00           | CAST-IN-PLACE CONCRETE FOR SKATEPARKS  |
| 03 39 00           | CONCRETE CURING FOR SKATEPARKS         |
| 03 40 00           | PRECAST CONCRETE FOR SKATEPARKS        |
| <br>               |  |
| <b>DIVISION 7</b>  | <b>THERMAL AND MOISTURE PROTECTION</b> |
| 07 92 00           | JOINT SEALANTS FOR SKATEPARKS          |
| <br>               |  |
| <b>DIVISION 16</b> | <b>ELECTRICAL</b>                      |
| 16000              | ELECTRICAL                             |

## SECTION 01000 - MOBILIZATION

### PART 1 - GENERAL

#### 1.1 RELATED DOCUMENTS

- A. The provisions of the "Standard Specifications for Public Works Construction," Latest Edition, Sections 7, 8, and 9, apply except as modified herein.

#### 1.2 SCOPE OF WORK

- A. Mobilization shall consist of preparatory work and operations including, but not limited to, those necessary for the movement of personnel, equipment, supplies, and incidentals to the project site; for the establishment of all offices and other facilities necessary for work on the project and for all other work and operations which must be performed or costs incurred prior to beginning work on the project site.

### PART 2 - MATERIALS

#### 2.1 CONSTRUCTION FENCING

- A. Prior to beginning any site work the contractor shall install a 6' tall (min.) temporary construction fence around the entire perimeter of the work as shown on plans. The fence shall be galvanized chainlink (new or used), free of openings or breaks in the fabric, with fence posts at 10' o.c. maximum. The fabric shall be minimum 2" diamond mesh, interwoven, 11 gauge twisted tight top and bottom. The posts shall be minimum 2" dia. schedule 40 galvanized pipe installed 24" into the ground. A concrete footing is not required.
- B. A gate or gates are to be located in such a way as to allow adequate access of workers and work vehicles. Site is to be kept secure, gates locked, at all times when work is not being performed at the site.
- C. The fence shall be maintained in place throughout the construction period and through to the end of the maintenance period. The temporary fence shall be removed prior to the final inspection/project acceptance at the end of the maintenance period.



2.2 TEMPORARY UTILITIES – NOT APPLICABLE

2.3 TEMPORARY TOILETS – NOT APPLICABLE

2.4 TEMPORARY OFFICE – NOT APPLICABLE

2.5 TEMPORARY TELEPHONE – NOT APPLICABLE

2.6 OFFICE EQUIPMENT – NOT APPLICABLE

2.7 TRASH REMOVAL AND CLEANING

- A. The Contractor shall provide trash receptacles for collecting debris and shall remove debris from the job site at regular intervals not less than weekly. The Contractor shall not park equipment on the street after work hours or overnight.

### PART 3 - EXECUTION

3.1 PAYMENT

- A. Payment for mobilization will be at the lump sum price bid for mobilization. Payment shall include full compensation for furnishing all labor, materials, tools, equipment, and incidentals, and for doing all the work in mobilization and demobilization as herein specified, 10% retention shall apply to all mobilization work.

END OF SECTION

## SECTION 01300 - SUBMITTALS

### PART 1 - GENERAL

#### 1.1 STANDARD SPECIFICATIONS

- A. The provisions of the Standard Specifications shall apply except as modified herein.

#### 1.2 SCOPE OF WORK

- A. The Work of this Section shall consist of furnishing all labor, materials, equipment, appliances and services necessary for the execution and completion of all Submittals Work as shown on the Plans and as described in the Specifications including, but not necessarily limited to, the following:
1. Preparation of Submittals Schedule;
  2. Submittals Planning;
  3. Submittals Preparation, Distribution and Transmittal, to include all of the following:
    - a. Product Data (Catalog Cuts)
    - b. Materials Lists
    - c. Samples
    - d. Record Drawings
    - e. Turn-over Items
    - f. Submittals Schedule updating and distribution

#### 1.3 RELATED WORK – NOT APPLICABLE

#### 1.4 SUBMITTAL PLANNING

- A. All submittals shall be turned over to the city for review at the **pre-construction meeting**. Additional submittals that require review throughout the project shall be turned over to the city as soon as available so as not to impact the project construction schedule. Contractor is responsible for staying on schedule.
- B. Processing Lead Time: Allow sufficient review time so that installation will not be delayed as a result of the time required to process submittals, including time for resubmittals.
1. Allow **two (2)** weeks for **initial** review. Allow additional time if processing must be delayed to permit coordination with subsequent submittals. The City Representative will promptly advise Contractor when a submittal being processed must be delayed for coordination.
  2. If a resubmittal is necessary due to corrections or revisions, process the resubmittal in the same manner as the initial submittal.
  3. Allow **two (2)** weeks for processing each **resubmittal**.
  4. No extension of Contract Time will be authorized because of failure to transmit submittals to the City Representative sufficiently in advance of the Work to provide the two week processing time specified.
- C. Coordination and Completeness:

1. Contractor shall coordinate preparation and processing of submittals with the performance of the related Work. Transmit each submittal allowing sufficient lead time to obtain appropriate reviews and approvals and to avoid delays in the related Work.
2. Coordinate the submittal date for each submittal with the lead time needed for fabrication, purchasing, testing, delivery, review of other related submittals, and related Work that require sequential processing/completion.
3. Coordinate the transmittal dates for each different type of submittal so processing will not be delayed. Ensure concurrent transmittal of submittals for related portions of the Work that need concurrent review to allow the Landscape Architect to verify that a coordinated work effort is being provided. City and Landscape Architect each reserves the right to withhold action on a submittal requiring coordination with other submittals until related submittals are received.
4. Contractor is responsible to verify completeness of all submittals. Incomplete submittals will be rejected.

### 1.5 SUBMITTALS SCHEDULE

- A. Concurrently with the development of Contractor's Construction Schedule prepare a complete "Submittals Schedule" for all submittals. Submit the Submittals Schedule together with the Construction Schedule at the Pre-Construction meeting.
  1. Coordinate the Submittals Schedule with all subcontractors, with the schedule of values, with the Materials Lists and with the Construction Schedule.
  2. Itemize items on the Submittals Schedule in the chronological sequence planned for submission; include all submittals required by the Contract Documents. Provide the following information:
    - a. Scheduled date for the initial submittal for each item.
    - b. Related Specification Section number.
    - c. Submittal category (i.e. Product Data, Samples, Record Documents, Shop Drawing, etc.).
    - d. Name of subcontractor or supplier as applicable.
    - e. Description of the portion of the Work covered by the submittal.
    - f. Record successive date(s) of any resubmittal(s).
    - g. Record date of City's approval of each submittal.
- B. Submittals Schedule Updating: Update the Submittals Schedule after each meeting or activity where revisions have been recognized or made.
- C. Distribution: Following receipt of review comments to the initial Submittals Schedule, on a monthly basis thereafter issue updated copies of the Submittals Schedule. Distribute copies to the Landscape Architect, the City Representative, all subcontractors, and all other parties required to comply with scheduled submittal dates. Keep an up to date copy of the Submittals Schedule posted in the Construction Office. Parties may be deleted from the distribution upon completion of all portion(s) of the Work assigned to such parties and such parties are no longer involved in construction activities.

### 1.6 SUBMITTALS PREPARATION AND TRANSMITTAL

- A. Preparation: Place a permanent label or title block on each submittal for identification. Indicate the name of the entity that prepared each submittal on the label or title block.

1. Provide a space approximately 4" x 5" on the label or beside the title block on Shop Drawings to record Contractor's review and approval markings and the action taken.
  2. Include the following information on the label for processing and recording action taken.
    - a. Project name.
    - b. Date.
    - c. Name and address of Landscape Architect.
    - d. Name and address of Contractor.
    - e. Name and address of subcontractor (as applicable).
    - f. Name and address of supplier.
    - g. Name of manufacturer.
    - h. Number and title of related Specification Section.
    - i. Drawing number and detail references, as appropriate.
- B. Transmittal: Package six (6) copies of each submittal appropriately for transmittal and handling. Transmit each submittal from Contractor to the City Representative using a transmittal form. Submittals received from sources other than Contractor may be returned without action. If a submittal is rejected, submit six copies of the resubmittal.
1. When transmitting submittals, record relevant information and requests for data on the transmittal form. Include a Contractor's certification that information submitted complies with the Contract Document requirements as a part of each submittal. If the submittal is not in full accordance with the Contract Documents, record specific deviations from the Contract Document requirements, including minor variations and limitations, either on the transmittal form or on a separate attached sheet that is referenced on the form.
  2. Transmittal Form: Use AIA Document G 810, or City approved equal.

## 1.7 SUBMITTALS PROCESSING AND DISTRIBUTION

- A. Processing: Upon receipt of the submittals, the City Representative will retain one copy and forward five to the Landscape Architect who will retain one, and will return four copies marked with action taken.
1. Except for submittals for record information or similar purposes, where action and return is required or requested the Landscape Architect will review each submittal, mark to indicate action taken, and return promptly.
  2. Verification of the submittals compliance with characteristics specified in the Contract Documents is Contractor's responsibility.
  3. Action Stamp: The Landscape Architect will stamp each submittal with a uniform, self-explanatory action stamp. The stamp will be appropriately marked, as follows, to indicate the action taken:
    - a. "No Exception Taken": When submittals are marked "No Exception Taken," that part of the Work covered by the submittal may proceed.
    - b. "Make Corrections Noted": When submittals are marked "Make Corrections Noted," that part of the Work covered by the submittal may proceed provided it complies with the notations and corrections marked on the submittal as well as the requirements of the Contract Documents.
    - c. Returned for Resubmittal: Submittals may be returned for resubmittal for various reasons. When a submittal is marked either "Submit Specified Item," "Rejected," or "Revise and Resubmit," Contractor shall not proceed with any part of the Work covered by the submittal, including purchasing, fabrication, delivery, or any other

associated activity. Instead, the submittal shall either be revised to comply with the Contract Documents and resubmitted, or a new submittal shall be prepared in accordance with the notations and submitted; resubmit without delay.

- d. Other Action: Where a submittal is primarily for information or record purposes, special processing or other activity, the submittal will be returned, marked "Action Not Required".
  - e. Contractor shall repeat the submittal process as specified above for all submittals as necessary to obtain an action mark that will allow the Work to proceed.
- B. Distribution: Upon receipt of marked copies of the submittals from the Landscape Architect, the City Representative will forward four copies of the marked submittal to the Prime Contractor for further distribution to the Subcontractor(s) and/or Supplier(s).
- 1. Do not proceed with the Work until an appropriately marked copy of the applicable submittal has been received from City and is in the installer's possession.
  - 2. Do not permit use of unmarked copies of submittals in connection with construction.
  - 3. Contractor shall not permit submittals marked "Rejected, "Submit Specified Item", or "Revise and Resubmit" to be used at the Project site, or elsewhere where Work is in progress.

## 1.8 PRODUCT DATA ("CATALOG CUTS")

- A. Submittal: Assemble Product Data submittals into a single submittal package for each construction trade or system. Submittals shall consist of a minimum of 6 copies. Product Data submittals shall include all available printed information such as manufacturer's installation instructions, catalog cuts, standard color charts, roughing-in diagrams and templates, standard wiring diagrams and performance curves. Where Product Data must be specially prepared because standard printed data is not suitable for use, submit as "Shop Drawings."
- 1. Mark each copy to show applicable choices and options. Where printed Product Data includes information on several products, some of which are not required, mark copies to delete inapplicable information. Product Data submittals, as a minimum, shall include the following information:
    - a. Manufacturer's printed recommendations.
    - b. Compliance with recognized trade association standards.
    - c. Compliance with recognized testing agency standards.
    - d. Application of testing agency labels and seals.
    - e. Notation of dimensions verified by field measurement.
    - f. Notation of coordination requirements.
  - 2. Do not submit Product Data until Contractor has confirmed the product's compliance with requirements of the Contract Documents.

## 1.9 SAMPLES

- A. General: Submit full-size, fully fabricated Samples cured and finished as specified, in the quantity specified in the respective Technical Specification section, and physically identical with the material or product proposed. Where quantities are not specified in the Technical Specification, submit a minimum of three samples, one will be returned marked with the action taken. Samples include partial sections of manufactured or fabricated components, cuts or containers of materials, color range sets, and swatches showing color, texture and pattern.

1. Mount, display, or package Samples in the manner specified to facilitate review of qualities indicated. Prepare Samples Submittals to match the Landscape Architect's Sample when available. Include the following:
  - a. Generic description of the Sample.
  - b. Sample source.
  - c. Product name or name of manufacturer.
  - d. Certification of compliance with the specified standards.
  - e. Availability and delivery time.
2. Submit Samples for review of kind, color, pattern, and texture, for a final check of these characteristics with other elements, and for a comparison of these characteristics between the final submittal and the actual component as delivered and installed. Where variation in color, pattern, texture or other characteristics are inherent in the material or product represented, submit multiple units (not less than 3), that show approximate limits of the variations.
3. Preliminary submittals: Where Samples are for selection of color, pattern, texture or similar characteristics from a range of standard choices, submit a full set of choices for the material or product. Preliminary submittals will be reviewed and returned with the Landscape Architect's mark indicating selection and other action.
4. Maintain appropriately marked sets of Samples, as returned by City, at the Project site for quality comparisons throughout the course of construction.

B. Distribution of Samples: If additional sets of samples are needed for distribution to subcontractors, manufacturers, fabricators, suppliers, installers, and others as required for performance of the Work, Contractor shall submit samples in sufficient quantities for such distribution. Do not distribute unmarked copies of sample to others involved in the Work.

**1.10 MATERIAL LISTS**

A. Submittal Requirements: Submitting a catalog number and manufacturer's name as a materials list stating that the items will be furnished to meet the Specifications will not be acceptable. Contractor shall submit a complete materials list for approval by the City Representative prior to performing any Work. Catalog data and full descriptive literature must be submitted whenever the use of items different than those specified is requested. Notarized certificate must be submitted by plastic pipe and fitting manufacturer indicating that material complies with the Project Specifications, unless material has been previously approved and used on other projects by City.

B. Material list shall be submitted in a format similar to the following:

| Item | Description          | Manufacturer | Model No. |
|------|----------------------|--------------|-----------|
| 1.   | Pressure Supply Line | Lasco        | Sch. 40   |
| 2.   | Lawn Head            | Rainbird     | 2400      |
| 3.   | etc.                 | etc.         | etc.      |

**1.11 "RECORD" PRINTS**

A. Changes: Record accurately on one set of blue-line prints all changes in the Work constituting departures from the original Contract Plans. For example, changes in pressure and non-pressure irrigation line locations.

Attachment: SPECIAL PROVISIONS - MVCP SKATE PARK (3355 : APPROVE AND EXECUTE AGREEMENT WITH MICON CONSTRUCTION FOR

- B. Legibility and Approval: The changes and dimensions shall be recorded in a legible and workmanlike manner to the satisfaction of City. Prior to final inspection of the Work, submit "record" prints to The City Representative for approval.
- C. Reference Points: Dimension from two permanent points of reference (buildings, monuments, sidewalks, curbs, pavement, etc.). Data to be shown on "record" prints shall be recorded day-to-day as the project is being installed.
- D. As-built Items: Show locations and depths of the following types of underground items:
1. Point(s) of connection for irrigation, domestic water, gas, sewer, electric and similar underground utilities.
  2. Routing of underground conduits, irrigation pressure lines and utility lines (dimension maximum 100 feet on center along routing).
  3. All types of valves in various piping systems, including gate valves, quick coupler and remote control valves.
  4. Routing of irrigation control wires.
  5. Related equipment (as may be directed).
- E. Maintain record prints on site at all times.

**PART 2 - MATERIALS – NOT APPLICABLE**

**PART 3 - EXECUTION – NOT APPLICABLE**

**END OF SECTION**

**SECTION 02100 - SITE DEMOLITION****PART 1 - GENERAL****1.1 RELATED DOCUMENTS**

- A. The provisions of the "Standard Specifications for Public Works Construction," latest edition, shall apply except as modified herein.

**1.2 SCOPE OF WORK**

- A. Work of this Section includes all material, equipment, and labor necessary for and incidental to completing all Site Demolition work complete, as indicated on the Drawings, as reasonably implied, or as specified and designated herein, including, but not limited to, the following:
1. Clearing and grubbing of all vegetation from site work areas.
  2. Removal and legal disposal of all deleterious materials.
  3. Removal and legal disposal of any additional deleterious items not specifically mentioned herein which may be found within the work limits.

**1.3 RELATED WORK SPECIFIED ELSEWHERE**

- A. Site Grading:                      Section 02210

**1.4 RESPONSIBILITY AND CO-ORDINATION**

CONTRACTOR SHALL SECURE AND MAINTAIN ALL REQUIRED PERMITS AND LICENSES AND PAY ALL FEES NECESSARY TO LEGALLY COMPLETE THE WORK OF THIS SECTION.

- A. Contractor shall notify utility companies for all utilities to be cut off, modified or relocated, and shall maintain and protect all active utilities.
- B. Contractor shall coordinate all work with the City in an effort to avoid any conflicts.

**1.5 PROTECTION AND SAFETY**

- A. Contractor shall provide signs and construction fencing in all necessary places to exclude persons, except those connected with the work, from entering the working area. Contractor is responsible for protecting the project site and adjacent properties from dirty water, mud and water accumulation due to Contractor's operations, rainfall run-off or any water that enters the project site from any other source.
- B. Contractor to protect from any hazards resulting from his operations.



## 1.6 SALVAGE MATERIALS

- A. All salvage materials are the property of the City. In the event that the City elects not to take possession of these materials, they then become the property of the Contractor and he must immediately remove them from the site.

## PART 2 - MATERIALS – NOT APPLICABLE

## PART 3 - EXECUTION

### 3.1 GENERAL

- A. No work of this section shall commence until the construction fence is in place.

### 3.2 SITE CLEARANCE AND DISPOSAL

- A. Contractor shall notify the City prior to start of demolition, to allow the City to salvage any site furnishings proper to their disposal. Demolition and paving removal work shall be carefully done to avoid damage to all existing facilities not designated for removal.
- B. Clear the site to be improved of weed growth, rubbish and debris, and concrete rubble, etc., that are to be removed for construction of the improvements shown on the construction plans. Roots three inches (3") in diameter and larger, and rocks and broken masonry larger than four inches (4") in the greatest dimension shall be removed to a minimum depth of twelve inches (12") below finished grade.
- C. All deleterious materials shall be disposed of off the site in a legal manner by the Contractor, who shall make all necessary arrangements and pay all related costs.

### 3.3 PROTECTION

- A. All existing trees, curbs, walls and concrete paving shall be protected in place unless otherwise noted on plans. Any damage to protected site features shall be repaired and/or replaced at the no additional cost to the city.

### 3.4 UTILITIES

- A. All known underground utilities are noted on the plans.
- B. All miscellaneous inactive underground facilities (e.g., drainage devices, cables, abandoned water lines, irrigation pipes, wiring, etc.), located twelve inches (12") or more below finish grade shall be removed as necessary for proper completion of the work. All miscellaneous active underground facilities that are encountered during the work shall be protected.
- C. Should the Contractor encounter any existing underground utilities not shown on the drawings, he shall at once notify the City Project Inspector who will determine further procedure.

**3.5 DEBRIS BURNING**

- A. Burning of debris will not be permitted.

**3.6 DUST CONTROL**

- A. Dust shall be kept to a minimum during site clearing operations by means of wetting the site with water or other approved method. After all site clear and grub operations are complete, sweep down all existing sidewalks and roadways on and off the site that have become soiled due to Contractor's operations.

**3.7 PAYMENT TERMS**

- A. Payment for site demolition work will be at the lump sum price bid for site demolition. Payment shall include full compensation for furnishing all labor, materials, tools, equipment, and incidentals, and for doing all the work in site demolition as herein specified. A 10% retention shall apply to all site demolition work.

**END OF SECTION**

**SECTION 02210 - GRADING****PART 1 - GENERAL****1.1 RELATED DOCUMENTS**

- A. The work of this section shall conform to the "Standard Specifications for Public Works Construction," latest edition, Section 300, except as modified herein.

**1.2 SCOPE OF WORK**

- A. Work of this Section includes all materials, labor and equipment necessary for and incidental to complete all Site Grading, as shown on the Drawings, as a reasonably implied, or as specified herein, including, but not limited to, the following:
1. Rough grading as shown on the plans, including cut, fill, backfill, and backfill compaction.
  2. Sub-grade preparation for walks, slabs, and other facilities.
  3. Fine grading of the work site.
  4. Excavation and backfill for all footings, structures, etc.
  5. Excavation and backfill of all sumps.
  6. Soil compaction as required.
  7. Soil testing as required.
  8. Protective measures.
  9. Dust and noise abatement

**1.3 RELATED WORK SPECIFIED ELSEWHERE**

- A. Site Demolition:                      Section 02110
- B. Planting:                                Section 02800
- C. Any irrigation or drainage work

**1.4 PROTECTION OF EXISTING ITEMS**

- A. The contractor shall furnish, place and maintain all shoring and bracing as may be required for protection of existing structures and utility services during execution of the work.

**1.5 QUALITY ASSURANCE**

- A. All work shall comply with the requirements of the "Grading Code of the City of Moreno Valley."

## PART 2 - MATERIALS

### 2.1 DRAIN ROCK

- A. Drain rock for all sumps shall be previous backfill as specified in the Standard Specifications, Section 300-3.5.2, Pervious Backfill.

## PART 3 - EXECUTION

### 3.1 GENERAL

- A. All demolition, clearing and grubbing of objectionable materials must be completed to the satisfaction of the City before starting any earthwork grading and excavation.
- B. Prior to initiating work of this section, the temporary construction fence shall be in place.

### 3.2 ROUGH GRADING

- A. Rough grading of the site shall be completed in accordance with indicated elevations and limit lines shown on the plans and shall allow for the depths of slabs, paving, play area infill, sub-base, topsoil, and compacted fills. Tolerance for rough grading is one tenth (1/10) of a foot. In all areas, appearance and positive drainage will be factors in the acceptability of grades.
- B. Graded material shall not be left in loose layers, but shall be stockpiled for use as compacted fill or compacted in thin layers as grading takes place in accordance with the requirements for compacted fill.
- C. All surface areas shall be graded so as to provide a minimum 1% surface drainage. The sub-grade surface shall be scarified twelve inches (12") deep prior to final grade preparation, and all loose surface rock two inches (2") and larger shall be removed. Dispose of all debris off-site in a legal manner.

### 3.3 SUB-GRADE PREPARATION

- A. Sub-grade for concrete walks and asphalt paving shall be prepared in accordance with Section 301-1 of The Standard Specifications. Scarify and cultivate the upper twelve inches (12") of sub-grade and compact to 95% relative compaction, minimum.

### 3.4 FILL AND COMPACTION

- A. All planting areas to receive fill shall be compacted to 90% except the top twelve inches (12") shall be placed at 85% relative compaction. The topmost twelve inches (12") of fill in all landscape areas shall be topsoil.
- B. Rocks and other debris larger than two inches (2") in diameter shall be removed from all fills to be compacted and be removed from site entirely.
- C. Fill material shall be spread in uniform lifts of six to eight inches (6"-8") of un-compacted thickness.

- D. Prior to starting compaction, the fill material shall be brought to optimum moisture content by spraying with water if too dry, and aeration if too wet.
- E. Thoroughly mix each lift to assure uniform distribution of water content.
- F. Bring fills to suitable elevations above required grades to provide for effects of shrinkage and settlement.
- G. For all areas designated to receive concrete pavement and within a perimeter two feet (2') outside these areas, each lift shall be compacted to a minimum of 95% of maximum density as determined by ASTM< D1557-70.
- H. Perform all compaction by suitable mechanical equipment and methods approved by the Soils Engineer.
- I. The contractor shall have tests performed to ensure that all parts of the pavement section, trench backfill, and general earthwork comply with the specifications. These tests will be performed at no cost to the City. Contractor shall pay for any retesting necessary because of failure of the materials or work to comply with the specifications on previous tests. Supply Landscape Architect with certificate of compaction compliance from licensed engineering testing laboratory.

### 3.5 EXCAVATION

- A. The contractor shall make all necessary excavation for footings and slabs and do any additional excavation necessary to provide ample room for installation of concrete forms where required.
- B. Footings shall be poured against undisturbed soil subject to the approval of the Soils Engineer.
- C. Bottom of excavations shall be level, free from loose material and brought to the indicated or required grades in undisturbed earth. All excavations shall be kept free from standing water. The Contractor shall do all pumping or draining that may be necessary in carrying on the work. Should excavations for footings, through error, be excavated to a greater depth or size than indicated or required, such additional depth or size shall be filled with concrete at the Contractor's expense.
- D. Excavations for sumps shall be of the size indicated on details and in locations indicated per plan.

### 3.6 BACKFILLING

- A. Selected site material shall be used for backfill of trenches and shall be free from large stones and clods. Material shall be as approved by the Soils Engineer.
- B. Backfill shall be deposited in layers of maximum six-inch (6") thickness.
- C. Layers of backfill shall be moistened with water, the amount to be controlled to insure optimum moisture conditions for the type of fill material used. Excess water causing saturated earth beneath footings, walks, and curbs is unacceptable.
- D. Backfill shall be compacted by suitable means to a minimum relative compaction of 95%.
- E. Backfill sumps in the manner indicated on drawings and with specified material.
- F. All trenches shall be backfilled in accordance with this section, and may be tested at the discretion of the Soils Engineer.

### 3.7 FINE GRADING

- A. Fine grading is to be performed upon completion of all trenching and backfill, and prior to soil preparation. Grades shall slope to drain without water pockets or irregularities and shall conform to the intent of all plans and specifications - after thorough settlement and compaction of the soil. Fine grading should allow for soil preparation work as specified under Section 02800, Planting, such that finish grades shall meet the elevations indicated on the plans. Tolerance for fine grading is one fourth inch (1/4"), plus or minus.

### 3.8 GRADING CERTIFICATION

- A. At the completion of fine grading and prior to commencement of site construction work the contractor shall have a topographic survey prepared of the project area and the final grades certified by a licensed land surveyor. The plan shall be reviewed and approved by the city representative prior to continuing with site construction.

### 3.9 PROTECTION

- A. It shall be the responsibility of the Contractor to prevent movement and settlement of grades related to, abutting, or adjoining the work site.
- B. Provide necessary temporary lighting, decking, flashers, blockades, planking and the like to maintain safe vehicular and pedestrian traffic adjacent to the work site.
- C. Provide adequate protection to all appurtenances outside contract limits. Any damage occurring from the Contractor's work shall be corrected to the previous condition at the Contractor's expense.

### 3.10 DUST CONTROL

- A. During all work under this Section, water shall be applied to the surfaces in the work area at frequent intervals and in sufficient quantities to allay the dust as necessary. Alternate dust control methods shall be used only as expressly approved by the City.

### 3.11 CLEAN-UP

- A. For the duration of work in this section, debris shall be removed as it accumulates. Accumulation of debris will not be permitted. Removal of debris shall be at the Contractor's expense, off-site and premises, and in a legal manner.

### 3.12 PAYMENT TERMS

- A. Payment for Grading will be at the lump sum price bid for Grading. Payment shall include full compensation for furnishing all labor, materials, tools, equipment, and incidentals, and for doing all the work in grading as herein specified, including painting parking stalls. A 10% retention shall apply to all Grading work.

### END OF SECTION

## SECTION 02441 - IRRIGATION SYSTEM

### PART 1 - GENERAL REQUIREMENTS

#### 1.1 DESCRIPTION

- A. Work Included: Unless otherwise specified, the construction of irrigation systems shall include the furnishing, installing and testing of mains, laterals, risers and fittings, quick couplers, gate valves, back flow preventers, furnishing and installing of irrigation controllers, booster pumps, excavation and backfill, and all other work in accordance with the plans and specifications for a complete operating system.
1. The intent of the drawings and specification is to indicate and specify a complete and efficient irrigation system ready for use in accordance with the manufacturer's recommendations and meeting the recommended approval of the Landscape Architect. All work shall be in accordance with applicable City codes, and these plans/specifications.
  2. Irrigation systems shall be constructed to the sizes and grades and at the location shown on the drawings. Lines shown on the plans are essentially diagrammatic. Locations of all heads, valves, etc., shall be reviewed by the Landscape Architect at the time of construction. Do not exceed spacing of the heads as shown on plans.
  3. The applicable provisions of the General Conditions and the Special Conditions of these specifications shall govern the work of this section as if herein written in full.
  4. The Contractor shall maintain, continuously, a competent superintendent or foreman, satisfactory to the City, during the progress of work, with authority to act for him in all matters pertaining to the work.
  5. Work noted as "N.I.C.", "existing" or "to be supplied and/or installed by others" is not a part of this section.
  6. The work in this section shall be coordinated with all underground utilities and trades responsible for their installation.
- B. Field Conditions: Verify drawing dimensions with actual field conditions. Inspect related work and adjacent surfaces. Report to the Landscape Architect all conditions which prevent proper execution of this work.
- C. Permits and Fees: The contractor shall apply and pay for all necessary fees and permits required in the pursuit of his work as required by governing codes.
- D. All assemblies specified herein shall be installed in accordance with the respective details. In the absence of detail drawings or specifications pertaining to the specific items required to complete the work, the Contractor shall perform such work in accordance with the best standard practice and to the satisfaction of the Landscape Architect.
- E. Irrigation Contractor is responsible for replacing or repairing any acts of theft or vandalism during construction and the maintenance period.
- F. Permission to shut off any water lines must be obtained from the City. Disruption of existing systems shall be kept to a minimum.
- G. Contractor shall maintain irrigation system throughout plant establishment and maintenance period.
- H. Contractor shall provide one year guarantee.

## 1.2 RELATED WORK DESCRIBED ELSEWHERE

- A. Planting: Section 02800

## 1.3 QUALITY ASSURANCE

- A. Codes and Standards: In addition to complying with all pertinent codes and regulations, comply with the latest rules of the National Electrical Code and the Electrical Safety Orders of the State of California, Division of Industrial Safety, for all electrical work and materials.
- B. Qualifications of Installers: Provide at least one person who shall be present at all times during execution of this portion of the work and who shall be thoroughly familiar with the type of materials being installed and the materials manufacturer's recommended methods of installation, and who shall direct all work performed under this Section.

## 1.4 SUBMITTALS

- A. General: Comply with the provisions of Section 01300.
- B. Product Data: Within 45 days after award of the Contract, and before any materials of this Section have been delivered to the job site, submit to the Architect:
1. A complete materials list of all items proposed to be furnished and installed under this Section.
  2. The manufacturer's recommended methods of installation which, when recommended for approval by the Architect, shall become the basis for review and accepting or rejecting actual installation methods used on the work when not otherwise specified or detailed.
- C. Materials and Samples: If materials are to be employed, other than designated on the plans, the Contractor shall, prior to the installation of any irrigation work, submit for recommended approval by the Landscape Architect, a list of materials and equipment he proposes to use. The material and equipment list shall include, but not be limited to, polyvinyl chloride pipe, automatic controllers and control valves, quick coupling valves and irrigation heads.
1. Should the Contractor propose to use materials or equipment other than those listed on the plans, he shall submit samples of the make and type proposed. Samples shall be submitted a sufficient time in advance of the start of construction to allow a period of not less than seven (7) days for testing and recommended approval.
  2. Recommended approval of irrigation equipment and materials shall depend on the following:
    - a. Conformance to specification requirements.
    - b. Acceptable test results and/or field performance.
    - c. Durability and low maintenance.
    - d. Availability of parts and service.
    - e. Compatibility with City's materials inventories.
- D. Project Record Drawings: Provide separate and complete Project Record Drawings prepared in accordance with the provisions of these Specifications, Sub-section 3.8, following



## 1.5 PRODUCT HANDLING

- A. Protection: Use all means necessary to protect the materials of this Section before, during, and after installation and to protect the work and materials of all other trades.
- B. Delivery: Polyvinyl chloride pipe shall be delivered to the work site in unbroken bundles or rolls packaged in such a manner as to provide adequate protection for the pipe ends, threaded or plain.
- C. Replacements: In the event of damage, immediately make all repairs and replacements necessary to the recommended approval of the Architect and at no additional cost to the City.

## PART 2 - PRODUCTS

### 2.1 "OR APPROVED EQUIVALENT" PRODUCTS

- A. This project is a Public Works project. Sole sourcing of material is not allowed. Any reference or call out on the plans and/or in the specifications to a specific manufacturer shall be interpreted as "or approved equivalent". The City and Landscape Architect's approval is required as to whether or not a product meets the City's standard to be an approved equivalent. **Bidders shall use the pricing for the products as specified to avoid risks of disapproval. No substitutions will be considered prior to the award of the contract.**

### 2.2 PIPE

- A. Plastic Pipe:
  - 1. Unless otherwise specified, the construction of lateral lines and main lines shall include excavation and backfill, the furnishing, installing and testing of pipe, tube and fittings, the furnishing and installing of anchors, thrust blocks and location wire, the improvements, line flushing and testing, and all other work in accordance with the plans and specifications.
  - 2. Main supply pressure lines shall be PVC; 4" and larger Class 200, 2" - 3" Class 315, 1 1/2" and smaller Schedule 40, as manufactured by Pacific Plastics, Inc., or approved equal.
  - 3. Lateral non-pressure lines shall be PVC. Schedule 40 polyvinyl chloride, as manufactured by Pacific Plastics, Inc., or approved equal.
  - 4. Irrigation Lines Sleeves shall be PVC. Schedule 40 polyvinyl chloride, as manufactured by Pacific Plastics, Inc., or approved equal.
  - 5. Low Voltage Control Wire Sleeves (valve wires) shall be PVC Schedule 40 polyvinyl chloride, as manufactured by Pacific Plastics, Inc., or approved equal. All exposed wires shall be sleeved in PVC Schedule 40 ULV electrical conduit with ULV Schedule 40 fittings.
    - a. Identification: All pipe shall be continuously and permanently marked with the following information: The normal pipe size, the type and schedule or class of material, the working pressure or pressure rating at 73.4 degrees F., the manufacturer's name or trade mark, and the National Sanitation Foundation (N.S.F.) seal of approval.
  - 6. All plastic pipe shall be guaranteed by its manufacturer to have passed, or be capable of passing, the Anhydrous Acetone Immersion Test and to be free from manufacturing defects.
- B. Identification: All pipe shall be continuously and permanently marked with the following information: The normal pipe size, the type and schedule or class of material, the working

pressure or pressure rating at 73.4 degrees F., the manufacturer's name or trade mark, and the National Sanitation Foundation (N.S.F.) seal of approval.

1. All plastic pipe shall be guaranteed by its manufacturer to have passed, or be capable of passing, the Anhydrous Acetone Immersion Test and to be free from manufacturing defects..

C. Polyvinyl Chloride Pipe Fittings and Connections:

1. Polyvinyl chloride pipe fittings and connections approved for irrigation systems shall be polyvinyl chloride, Type II, Grade I, Schedule 40, high impact molded fittings, manufactured from virgin compounds.
2. The Schedule 40 fittings shall be tapered socket type, or molded thread type, suitable for either solvent weld or screwed connections.
3. Machine threaded fittings will be acceptable only if thread-stripping resistance test results are submitted and approved.
4. In line fittings, such as couplings, unions and bushings may be machined from extruded stock.
5. Plastic saddle and flange fittings will not be acceptable.
6. All fittings shall be permanently marked with the following information: The normal pipe size, the type and schedule of material, and the National Sanitation Foundation (N.S.F.) seal of approval.

D. Galvanized Pipe and Fittings:

All galvanized steel pipe shall be Schedule 40, threaded, coupled and hot-dip galvanized, and shall comply with ASTM A120 and A53.

1. All fittings for galvanized steel pipe shall be 150 PSI rated galvanized malleable iron, banded pattern.
2. Pipe sizes indicated on the drawings are nominal inside diameter unless otherwise noted.

## 2.3 VALVES

A. Ball Valves:

1. All ball valves shall be all bronze construction full port; 1/2" thru 2", Nibco T585.
2. Working Pressure Rated: 150 PSI stem, 400 PSI W.O.G.
3. Ball valves installed underground shall be housed in a rectangular plastic valve box.

B. Gate Valves:

1. All gate valves shall be all bronze construction full port; 1/2" thru 2", Nibco T113.
2. Working Pressure Rated: 200 PSI non rising stem, screw in bonnet, solid wedge.

C. Butterfly Valves:

1. All butterfly valves shall be 2 1/2" and larger, Nibco WD2000.
2. Butterfly valves installed underground shall be housed in a rectangular plastic valve box.

D. Automatic Control Valves (Electric):

1. All automatic control valves (electric) shall be as called for on plans, electrically controlled, hydraulically operated, single seat, normally closed no equivalents or equals.

2. The valves shall be actuated by a normally closed solenoid valve operator using 24 volts, 60 cycle alternating current. The wires in the coil of the solenoid shall be embedded in an epoxy resin. Valves shall automatically close in event of electrical power failure.
3. All automatic control valves shall have a flow control device for manually adjusting the amount of flow of water through the valve. The flow control device shall be adjusted so that the pressure at the nozzle of the irrigation head farthest from the automatic control valve shall be that as specified in the irrigation legend per plan. The pressure at the irrigation head shall be measured by means of a pilot pressure gauge while the irrigation head is operating.
4. Automatic control valves shall be constructed of brass or stainless steel springs and screens, and composition material (neoprene) seals and seat washers.
5. Valve stems shall have a cross handle.
6. All automatic control valves shall be equipped with a pet clock for manual operation control.
7. The Contractor shall furnish one valve box key for each six or less valve boxes installed.
8. All valves shall have a valve marking tag per Landscape Details on plans

## 2.4 QUICK COUPLERS

- A. Quick couplers shall be as called out for on plans.

## 2.5 CONTROLLERS AND WIRE

- A. Automatic Controllers – NOT APPLICABLE
- B. Control Wire:
  1. All control wire shall be of the Underwriter's Laboratory type UF (underground feeder), single conductor, solid copper, plastic insulated, 600 volt rated, for direct burial applications. Maximum conductor operating temperature, 60 degrees C. for both wet and dry locations. Wire composition is as follows:
    - a. Conductor - The conductors shall be solid annealed uncoated copper meeting the applicable requirements of the latest revisions of A.S.T.M. B-3.
    - b. Insulation - The insulation shall be colored plastic which meets the test requirements of I.P.C.E.A. (The Insulated Power Cable Engineer's Association) Pub. No. S-61-402, dated July 1961, Section 3.7 for 60 degrees C. polyvinyl chloride insulation. The insulation shall be flame retardant, resistant to fungus, resistant to corrosive fumes, suitable for wet locations and furnish some degree of inherent protections against mechanical abuse. Insulation thickness shall be 47 mils for AWG #14, 12 & 10, and 62 mils for AWG #8.
    - c. Color Coding - The conductor insulation shall be color coded as follows:
      - 1) All common ground wire shall be white.
      - 2) All pilot (valve control) wire shall be black.
    - d. All wire splices shall be made within a control valve box or a separate valve box. Each splice shall be made with a Spears Dri-Splice DS-100 wire connector and filled with Spears DS-300 sealant.

## 2.6 VALVE BOXES

- A. Valve Boxes shall be as called for on plans

## 2.7 IRRIGATION HEADS

### A. Irrigation Heads:

1. Irrigation heads shall be as called for on plans. Irrigation heads shall be of the types and sizes, with the diameter (or radius) of throw, pressure, discharge and any other designations necessary to determine the types and sizes, as indicated on the plans.
2. All irrigation heads of a particular type of function in the system shall be of the same manufacture and, with the exception of shrubbery heads, shall be marked with the manufacturer's name and model number. This identification shall be visible without having to remove the irrigation head from the system.
3. Unless otherwise specified, all irrigation heads & body shall be constructed of cyclac with the following exceptions: bearings, washers, gaskets, seals, spray pins and rocker arms.

## 2.8 POP UP ROTOR:

- A. All pop-up rotors shall have a rubber cover and be constructed of heavy duty plastic except for wiper seal, bearing spring and bearing washers. The riser shall be constructed of plastic or of plastic encased in a stainless steel sleeve. All rotors to have a reinforced rib design with flange encasement.
- B. Pop-up height shall be as listed in drawings and in no case be shorter than 3-1/2 inches.
- C. The rotor shall have a diffuser pin for regulating flow and radius.
- D. The rotor shall have a screen to protect it from clogging and have a minimum inlet of 3/4 inch.
- E. Medium Range rotors shall be capable of covering 16-55 feet radius at 20-60 PSI with a rate of .5 - 9.2 GPM. and be adjustable from 1-360 degrees. Long range rotor shall be capable of covering 16-55 feet radius at 40-74 PSI with a rate of 3.8 - 27.5 GPM. and be adjustable from 1-360 degrees.

## 2.9 DRIP VALVE ASSEMBLIES:

- A. Electric Remote Control Valves: Electric control valves with pressure regulating feature two way solenoid, pilot operated made of synthetics, non corrosive material; diaphragm activated and slow closing. Include freely pivoted seat seal, retained (mounted) without attachment to diaphragm.
- B. Wye Strainer: 150 mesh screen for point to point drip
- C. Isolation Ball Valve: Ball Socket Ball Valve with thermoplastic molded one piece construction and teflon seat with EDPM cushions.

## 2.10 SUB SURFACE DRIP IRRIGATION:

### A. Drip Tubing For Subsurface Drip Tubing:

1. Nominal sized 1/2" low density, ultra-violet resistant, linear polyethylene tubing with internal pressure-compensating, continuous self-cleaning, integral drippers at a specified interval. The tubing shall be brown in color and conform to an outside diameter (O.D.) of 0.66" and an inside diameter (I.D.) of 0.57". The dripperline shall be capable of a discharge rate of 0.4, 0.6 or 0.9 gallons per hour (GPH) between operating pressures of 7-70 PSI for each individual dripper.

2. The individual continuous self-cleaning, pressure compensating drippers shall be welded to the inside of the tubing wall. The drippers shall be constructed of three individual pieces:
  - a. a black-colored dripper containing a filtration system on the inlet side, compensation cell, and a recessed chamber with a water outlet,
  - b. a hard plastic diaphragm retainer with color denoting discharge rate, with chamfered edges and recessed groove in the center extending the full length of the diaphragm and,
  - c. a flexible black elastomer diaphragm that allows pressure to build up within the chamber to purge sediment or other debris that may not have been captured by the disc filter.
  - d. Dripper spacings shall be available in the following on-center intervals – 12”, 18”, and 24”.

**B. Pressure Regulator Valves For Subsurface Drip Tubing:**

1. The pressure regulator valve(s) shall be a spring-operated piston type with an externally accessible regulation unit that can be serviced without removing the valve from the system. The valve shall be constructed from molded black plastic with six different colored tops with interchangeable springs denoting different pressure regulation and flow ranges. The regulator shall have a built-in indicator that shows when the proper outlet pressure is reached. Operating ranges for the valves shall be from 15-50 PSI in 5-PSI increments. Inlet and outlet ports of the valve shall be a combination of male/female threads.

**C. Disc Filter For Subsurface Drip Tubing:**

1. The disc filter body shall be molded of black plastic with male pipe threads (MPT) for both the inlet and outlet ports. A threaded cap on one end of the body shall be capable of periodic servicing by unscrewing the cap or releasing the latched band from the main filter body. On one ¾” model, a manual shut-off valve shall be co-molded to the opposing end of the removable cap as part of the main body. This device shall be capable of closing off the inlet port so the disc element can be removed when the main line is still pressurized.

**D. Air /Vacuum Relief Valves for Subsurface Drip Tubing:**

1. Air / vacuum relief valves shall be constructed of grey and/or black plastic with an internal sliding poppet valve that is capable of venting air or preventing vacuum.. The main body shall have a ½” male pipe thread (MPT). Operating pressure range for the air/vacuum relief valve shall be 7 PSI minimum to 140 PSI maximum.

**E. Stainless Steel Clamps for Subsurface Drip Tubing:**

1. Tubing clamps shall be constructed to 304 AISI stainless steel and shall be one “ear” type. This “ear” shall be capable of being pinched with a pinching tool to secure the tubing around the barbed insert fitting. Interior clamp wall shall be smooth to prevent crimping and pinching of tubing. Wall thickness of clamps shall be .0236” (0.6mm) with an overall band width of ¼” (7 mm).

**2.11 CHECK VALVES:**

- A. Swing Check Valves: PVC, Slip x Slip check valves, for non-pressure lateral line applications on slopes.
- B. Spring Check Valves: for pop-up spray heads and spray heads on risers and ¾” for popup rotors and rotors on risers.

**2.12 FLUSH VALVE ASSEMBLIES:**

- A. Schedule 80 Ball Valve, threaded schedule 80 nipples and fittings with polyethylene tubing for flush hose.

**PART 3 - EXECUTION****3.1 SURFACE CONDITIONS**

- A. Inspection:
1. Prior to all work of this Section, carefully inspect the installed work of all other trades and verify that all such work is complete to the point where this installation may properly commence.
  2. Verify that irrigation system may be installed in strict accordance with all pertinent codes and regulations, the original design, the reference standards and the manufacturer's recommendations.
- B. Discrepancies:
1. In the event of discrepancy, immediately notify the Landscape Architect.
  2. Do not proceed with installation in areas of discrepancy until all such discrepancies have been fully resolved.

**3.2 FIELD MEASUREMENTS**

- A. General:
1. Trenches and other excavations for irrigation pipe and appurtenances shall be excavated true to alignment and grade, and shall be of ample size for the proper performance of installation work, review, testing and backfill.
  2. Where it is necessary to excavate adjacent to existing trees, the Contractor shall use all possible care to avoid injury to trees and tree roots.
  3. Protect all existing utilities and repair any damage to existing utilities with matching new materials, at no increase in contract price.
  4. Generally, piping under concrete shall be installed by jacking, boring or hydraulic driving. Where any cutting or breaking of sidewalks and/or concrete work is necessary, it shall be removed and replaced by the Contractor. Permission to cut or break sidewalks and/or concrete shall be obtained from the Architect. No hydraulic driving will be permitted under asphaltic concrete paving.
  5. Coordinate with planting operations, as 10" deep cross-ripping is required prior to irrigation systems installation. (Cross-ripping is part of the planting work).
- B. Plastic Pipe Trenches:
1. Minimum trench width shall be six (6) inches.
  2. Minimum trench depth below bottom of pipe shall be two (2) inches.
  3. Minimum cover shall be based on finished grades, unless otherwise noted on Drawings.
    - a. Lateral Line minimum cover shall be twelve (12) inches.
    - b. Main Line minimum cover shall be eighteen (18) inches.
    - c. Pipe and Wire Sleeves minimum cover shall be twenty-four (24) inches.

C. Backfill Material:

1. All plastic pipe shall be bedded and encased with approved backfill material free of rocks and clods as indicated in the following table and/or shown on the plans.
  - a. Thickness Under Pipe Minimum Two (2) inches
  - b. Thickness Above Pipe Minimum Four (4) inches
  - c. Thickness at Side of Pipe Minimum Two (2) inches
2. The balance of backfill material shall be approved soil. Unsuitable material, including clods and rocks over 2 to 2-1/2 inches in size, shall be removed from the premises and disposed of legally at no cost to the City.
3. Backfill material shall be sufficiently compacted under and on each side of the pipe to provide support free of voids. On slope areas over 3:1 gradient compaction shall be 85% (min) or equal to the requirements of the grading plans, whichever is greater. Pipe joints shall remain exposed until the completion of pressure and leakage test, unless authorized by the Architect. The top six (6) inches of backfill shall be free of rocks over one (1) inch, subsoil, rubbish and debris.
4. The remainder of the backfill material shall contain no lumps or rocks larger than two and one-half (2-1/2) inches, nor contain rubbish and debris.
5. Backfill shall be tamped or puddled to the dry density of adjacent soil. Backfill within areas of structurally compacted soils shall be returned to the original relative density as before trenching.

D. Location Wire:

1. Location wire shall be placed on top of the four-inch select backfill over all mainline (pressure bearing) pipes, except copper pipe. Wire shall be No. 12 gauge copper, new or used or an approved substitute, and shall provide a continuous electrical conductor between gate valves and control valves. Each end shall be brought to the valve sleeve and two feet of wire looped free in the trench beside the valve body. This location wire may be omitted where copper hydraulic control tubing or electric control wire follows the water main.

### 3.3 INSTALLATION OF POLYVINYL CHLORIDE PIPE

- A. Polyvinyl chloride pipe shall be installed in such a manner so as to provide for expansion and contraction as recommended by the manufacturer.
- B. All polyvinyl chloride pipe shall lay free in the trench with no induced strain. Where there is evidence of induced pipe strain, the Contractor shall be required to make pipe cuts and install angle fittings as necessary to eliminate the strain.
- C. When a connection is plastic to metal, a female adapter shall be used. The metal nipple shall be hand-tightened, plus one turn with a strap wrench. Joint compound shall be Permatex, Type 2, or Teflon Tape.
- D. The Contractor will be required to remove and replace any fitting which induces a torque strain to the pipe.
- E. Polyvinyl chloride pipe shall be cut with a PVC pipe cutter, hand saw or hack saw with the assistance of a square and sawing vise or in a manner so as to ensure square ends. Burrs at cut ends shall be removed prior to installation so that a smooth unobstructed flow will be obtained.
- F. All plastic to plastic joints shall be solvent-weld joints. Only the solvent recommended by the pipe manufacturer shall be used.

- G. The solvent-weld joints shall be made in the following manner:
1. Thoroughly clean the mating pipe and fitting with a clean dry cloth.
  2. Try the parts for fit. The parts should "dry-mate" between one-third and two-thirds the depth of the socket. If adequate insertion is not obtained, or bottoming occurs, try another part until a satisfactory "dry-fit" is obtained.
  3. Apply a uniform coat of solvent to the outside of the pipe with a non-synthetic bristle brush.  
NOTE: For PVC. Type I, 1120-1220, pipe mating surface shall first be cleaned with the application of Methyl Isobutyl Ketone (MIBK) solvent. This cleaning shall be accomplished by applying MIBK solvent to the full mating surface area and wiping off with a clean cloth, repeating the process, if necessary, until no trace of shine remains (neither streaks nor spots). The use of commercial PVC Solvent-cement thinners as a substitute of MIBK is not allowed.
  4. Apply a uniform coat of solvent-weld to the fitting socket.
  5. Re-apply a light coat of solvent-weld to the pipe and quickly insert it into the fitting.
  6. Give the pipe or fitting a quarter turn to ensure even distribution of the solvents and make sure that the pipe is inserted to the full depth of the fitting socket.
  7. Hold in position for at least 15 seconds.
  8. Wipe off excess solvent that appears at the outer shoulder of the fitting.

### 3.4 INSTALLATION OF CONTROL WIRE

- A. Unless otherwise specified, the installation of control wire shall include excavation and backfill, the furnishing, installing and testing of the wires, the removal and/or restoration of existing improvements and all other work in accordance with the plans and specifications.
- B. Unless otherwise specified all neutral (common ground) wire shall be AWG #12 and all pilot (valve control) wire shall be AWG #14.
- C. At least one spare wire shall be installed from the controller clock to the most distant valve. When wire runs go in different directions from the controller clock, a separate spare wire shall be installed from the controller clock to the most distant valve in each different wire run direction.
- D. Tape and bundle all control wires at 10' o/c maximum; place wiring with 18" minimum cover. When wiring is placed in common trenches with piping, set wiring 2" from any piping.
- E. All wire splicing shall take place in the valve boxes and/or pull boxes. All splices shall be made with a mechanical connector encased in a self-curing epoxy resin which provides a permanent watertight connection.
- F. All direct burial control wires shall be identified as to their respective valve number and controller clock letter in all pull boxes and at all wire termination. Spare wires and "future valve" wires, if any, shall also be identified. Labels and tags shall be used for identification which are not affected by moisture or temperatures between minus 30 degrees F. and plus 200 degrees F. The labels and tags shall be resistant to abrasion, dirt, grease, and chemicals used in lawn fertilizers and conditioners. The labels and tags shall be firmly attached to the wire in every case. The Contractor shall submit samples of the labels or tags to be used, to the Architect for recommended approval, prior to the installation of the control wire. Examples of nomenclature of tags or labels are as follows:
  1. Neutral (common ground) wire = "Neutral" Clock "A"
  2. Pilot (valve control) wire = "A.V. #1." Clock "A"
  3. Spare Wire = "Spare" Clock "A"



- G. The final operating sequence of the remote control valves, within each individual controller clock, shall be as called out on drawings.
- H. Testing:
  - 1. All direct burial control wire installed shall be tested in the following manner.
    - a. Before any backfill material is placed over the control wires in the trench, the wires shall be tested with a meter for insulation resistance. Minimum insulation resistance to ground shall be fifty (50) megohms. Any conductor not meeting this requirement shall be replaced.
    - b. After backfill encasement, the wires shall again be tested with a meter. The minimum acceptable insulation resistance to ground on this test shall be one (1) megohm. Any conductor not meeting this requirement shall be replaced.
- I. Provide separate common wire for each controller installed.

### 3.5 INSTALLATION OF VALVES

- A. General: Unless otherwise specified, the installation of the valves shall include excavation and backfill, the furnishing, installing and testing of risers, fittings and valves, the furnishing and installing of appurtenances, accessories, anchors and thrust blocks, the removal and/or restoration of existing improvements and all other work in accordance with the plans and specifications.
- B. Group control valves together as specified on the drawings with a minimum spacing of 36" between each valve box.
- C. Automatic control valves shall be set upright with a minimum clearance of 3" between top of cross and bottom of valve box lid. The Contractor shall brand, the identification number of the valve and clock on the outside cover of the box.

### 3.6 INSTALLATION OF IRRIGATION HEADS

- A. Unless otherwise specified, the installation of irrigation heads shall include excavation and backfill, the furnishing, installing and testing of risers, fittings and heads, the furnishing and installing of anchors and thrust blocks, the furnishing and installing of cone shaped screens at base of each head, the removal and/or restoration of existing improvements and all other work shall be in accordance with the plans and specifications.
- B. Flushing: All water lines shall be thoroughly out before heads are installed.
- C. Location and arc of heads shall be adjusted, if required to eliminate any dry spots, over water or spillage on adjacent areas.
- D. All turf area irrigation heads to be installed adjacent to existing walks, curbs, or other paved areas, shall be set to the grade of the improvements. Irrigation heads which are to be installed in areas where the turf has not yet been established shall be set one (2) inches above the proposed finished grade. Heads installed in this manner shall be lowered by the Contractor prior to final acceptance. In established lawn areas the irrigation heads shall be set to existing grade.

### 3.7 DRIP IRRIGATION SPECIALTY INSTALLATION

- A. Install drip tubing per plans and details.

- B. Install application pressure regulators in piping near device being protected, and in control-valve boxes.
- C. Install air relief valves and vacuum relief valves in piping, and in control-valve boxes.

### 3.8 DRAWINGS OF RECORD AND TURNOVER ITEMS

- A. Record Drawings: The Contractor shall provide and keep up to date, a complete record set of bond prints which shall be corrected daily and show every change from the original drawings and specifications and the exact locations, sizes and kinds of equipment. Prints for this purpose may be obtained from the City. This set of drawings shall be kept on the site and shall be used only as a record set.
- B. The drawings shall also serve as work progress sheets, and the contractor shall make neat and legible annotations thereon daily as the work proceeds, showing the work as actually installed. These drawings shall be available at all times for inspections and shall be kept in a location designated by the City.
- C. In order to complete the record drawings in a neat, legible manner, the contractor shall employ a competent draftsman, satisfactory to the City's authorize representative, to indicate the necessary changes on mylar tracings or revised CAD drawings procured from the City and deliver same to the City two weeks prior to the final review by the Architect.
- D. The contractor shall dimension from two (2) permanent points of reference, building corners, sidewalks, or road intersections, etc., the location of the following items:
  1. The routing of the irrigation main lines
  2. Connections to the existing water lines
  3. Control valves and Butterfly valves
  4. Hose Bibs
  5. Any other pertinent underground item, if so deemed by the Landscape Architect.

### 3.9 TESTS

- A. Pressure Tests:
  1. All pressure lines shall be tested under hydrostatic pressure of 125 pounds per square inch, and all non-pressure lines shall be tested under the existing static pressure and both be proved watertight. Contractor shall provide all equipment for hydrostatic tests at no cost to the City.
  2. Pressure shall be sustained in the lines for not less than two (2) hours. If leaks develop, the joints shall be replaced and the test repeated until the entire system is proved watertight.
  3. Tests shall be observed and recommended for approval by the Landscape Architect prior to backfill.
- B. Coverage Test:
  1. When the irrigation system is completed, the Contractor, in the presence of the Architect, shall perform a test coverage of water afforded the planting areas, complete and adequate. The Contractor shall furnish all materials and perform all work required to correct any inadequacies of coverage disclosed arising from his work.
  2. Contractor shall inform the City's representative of any deviation from the plan required due to wind, planting, soil or site conditions that bear on proper coverage; and upon approval, perform changes to provide for proper coverage at no additional cost to the City.

**3.10 REVIEWS**

- A. Normal Progress Reviews: Normal progress reviews shall be requested from the Architect at least 48 hours in advance of any anticipated review. A review will be made by the Architect on each of the steps listed below. The Contractor will not be permitted to initiate the succeeding steps of work until he has received written approval to proceed by the inspector.
  1. Immediately prior to the commencement of the work of the section.
  2. Irrigation materials and equipment to be used.
  3. After trenching and before backfill.
  4. Completion of line testing, test to be made prior to backfill.
  5. After placement of all heads, bubblers, emitters, valves and controllers for coverage.
  6. Final review and receipt of "Record Drawings"/"Controller Charts".
  7. Final acceptance of project by City.
  8. In no event shall the Contractor cover up or otherwise remove from view any work under this contract without prior approval. Any work covered prior to review shall be opened to view by the Contractor, at his expense.
  
- B. Unprepared Review Requests: In the event the Contractor requests review of work and said work is incomplete, the Contractor shall be responsible for review cost.
  
- C. Completion: The work will be accepted, in writing, when the whole shall have been completed satisfactorily to the City and the Architect. In judging the work, no allowance for deviation from the original plans and specifications will be made unless already approved by City, in writing, at the proper times.
  1. Leave the entire installation in complete operating order, free from any and all defects in material, workmanship or finish, regardless of any discrepancies and/or omissions in plans or specifications.
  2. Remove from the site all debris and rubbish resulting from the work, and leave the installation in clean condition.

**3.11 GUARANTEE**

- A. General: The entire irrigation system, including all work done under this contract, shall be guaranteed against all defects and fault of material and workmanship for a period of one (1) year following the filing of the Notice of Completion. All materials used shall carry a manufacturer's guarantee of one (1) year.

Should any problem with the irrigation system be discovered within the guarantee period, it shall be corrected by the Contractor at no additional expense to the City within ten (10) calendar days of receipt of written notice from the City. When the nature of the repairs as determined by the City constitute an emergency (e.g. broken pressure line) the City may proceed to make repairs at the Contractor's expense. Any and all damages to existing improvement resulting either from faulty materials or workmanship, or from the necessary repairs to correct same, shall be repaired to the satisfaction of the City by the Contractor, all at no additional cost to the City.

- B. Form of Guarantee: Guarantee shall be submitted on Contractors own letterhead as follows:

**FORM OF GUARANTEE FOR IRRIGATION SYSTEM**

We hereby guarantee that the irrigation system we have furnished and installed is free from defects in materials and workmanship, and the work has been completed in accordance with the drawings and specifications, ordinary wear and tear and unusual abuse, or neglect excepted. We agree to repair or replace any defects in materials or workmanship which may

Attachment: SPECIAL PROVISIONS - MVCP SKATE PARK (3355) : APPROVE AND EXECUTE AGREEMENT WITH MICON CONSTRUCTION FOR

develop during the period of one year from date of filing of the Notice of Completion and also the repair or replace any damage resulting from the repairing or replacing of such defects at no additional cost to the City. We shall make such repairs or replacements within 10 calendar days following written notification by the City. In the event of our failure to make such repairs or replacements within the time specified after receipt of written notice from the City, we authorize the City to proceed to have said repairs or replacements made at our expense and we will pay the costs and charges therefore upon demand.

PROJECT: \_\_\_\_\_  
LOCATION: \_\_\_\_\_  
SIGNED: \_\_\_\_\_  
ADDRESS: \_\_\_\_\_  
\_\_\_\_\_  
PHONE: \_\_\_\_\_

- C. After the system has been completed, the Contractor shall instruct the City in the operation and maintenance of the system and shall furnish a complete set of operating instructions.
- D. Any setting of trenches which may occur during the one-year period following acceptance shall be repaired to City's satisfaction by the Contractor without any additional expense to the City. Repairs shall include the complete restoration of all damage to planting, paving or other improvements of any kind as a result of the work.

**3.12 MAINTENANCE**

- A. Maintenance of irrigation system prior to job completion, and during the Landscape Maintenance period, shall be the responsibility of the Contractor including, but not limited to, the following:
  - 1. Cleaning of plugged irrigation heads.
  - 2. Irrigation heads adjustments.
  - 3. Volume of water being applied (coordinate with landscape maintenance.)
  - 4. Programming of the controller (coordinate with landscape maintenance.)
  - 5. Repairing leaking valves, etc.
  - 6. Any other problem areas which occur after installation attributed to the irrigation system.
  - 7. Repair or replace equipment due to acts of vandalism, theft or pest damage.
  - 8. Lower all seeded area heads to final grades prior to final acceptance by City.

**3.13 PAYMENT TERMS**

- A. Payment for irrigation work will be at the lump sum price bid for irrigation. Payment shall include full compensation for furnishing all labor, materials, tools, equipment, and incidentals, and for doing all the work in irrigation as herein specified. A 10% retention shall apply to all irrigation work.

**END OF SECTION**

Attachment: SPECIAL PROVISIONS - MVCP SKATE PARK (3355 : APPROVE AND EXECUTE AGREEMENT WITH MICON CONSTRUCTION FOR

## SECTION 02800 - PLANTING

### PART 1 - GENERAL

#### 1.1 RELATED DOCUMENTS

- A. The provisions of the "Standard Specifications for Public Works Construction, (SSPWC)" latest edition, shall apply except as modified herein.

#### 1.2 SCOPE

- A. Work of this Section includes all material, equipment, and labor necessary for and incidental to completing all Landscape Planting work as indicated on the Drawings, or as reasonably implied, or as designated herein, including, but not limited to, the following.
1. Soil testing approvals.
  2. Weed abatement.
  3. Soil preparation.
  4. Finish grading.
  5. Preparation of all planting holes.
  6. Furnishing and installation of all plant materials unless otherwise noted.
  7. Sodding indicated turf area.
  8. Furnishing and installation of all required fertilizers, planting backfill materials, top
  9. Dressing and miscellaneous materials.
  10. Providing plant establishment (30 days).
  11. Providing landscape maintenance (90 days).
  12. Clean-up and weeding of all landscape areas.
  13. One year guarantee.

#### 1.3 RELATED WORK SPECIFIED ELSEWHERE

- A. Earthwork: Section 02200
- B. Irrigation: Section 02441

#### 1.4 QUALITY ASSURANCE

- A. The Contractor shall provide at least one person who shall be present at all times during execution of this portion of the work, who shall be thoroughly familiar with the type of materials being installed and the proper materials and methods for their installation, and who shall direct all work performed under this Section.
- B. All plants and planting material shall meet or exceed the specifications of Federal, State and County laws requiring inspection for plant disease and insect control.

- C. Quality and size shall conform with the current edition of "Horticultural Standards" for number one grade nursery stock as adopted by the American Association of Nurserymen, and California Department of Agriculture regulations.
- D. The Applicator of all weed control materials shall be licensed by the State of California as a Pest Control Operator and a Pest Control Advisor in addition to any subcontractor licenses that are required.
- E. All materials and methods used for Weed Abatement must conform to Federal, State, and Local Regulations.

### 1.5 APPROVALS

- A. All irrigation system work shall be inspected for recommended approval by the Landscape Architect and/or the City prior to start of any work in this section.

### 1.6 TESTING

- A. An Agricultural Soil Suitability Report for all planting areas shall be obtained by the Contractor, after completion of rough grading, and prior to start of soil preparation work. The Contractor, at his own expense, shall submit at least four (4) site soil samples to a Soil Laboratory recommended by the Landscape Architect. Samples are to be taken from the top six inches (6") of soil in areas to receive planting. All test results and recommendations shall be provided to the Landscape Architect and/or the City. The requirements for fertilization and amendments as specified herein, may be modified as necessary prior to start of work in this section.
- B. After the completion of soil preparation and prior to the start of any planting, soil samples shall again be taken. Quantity and methods shall be the same as previously executed. Contractor shall not commence planting until so directed by the Landscape Architect and the City.

### 1.7 SUBMITTALS

- A. Materials lists: Within forty-five (45) days after award of the Contract, submit a complete list of all materials proposed to be furnished and installed under this Section, demonstrating complete conformance with the requirements specified.
  - 1. Materials list shall include the weed control materials and quantities per acre intended for use in controlling the weed types prevalent and expected on the site, as supplied by the Pest Control Advisor. Pest Control Advisor shall furnish the Landscape Contractor and Landscape Architect data to demonstrate the compatibility of the weed control materials and methods with the intended plant and seed varieties.
- B. Certificates: Deliver all certificates to the Landscape Architect upon delivery to job site. Include:
  - 1. Quantity of commercial fertilizers used.
  - 2. Quantity of soil amendments.
  - 3. Quantity of seed.
  - 4. Quantity of plant material.

### 1.8 PRODUCT HANDLING

- A. Delivery and Storage:

1. Deliver all items to the job site in their original containers with all labels intact and legible at time of Landscape Architect's review.
  2. Immediately remove from the site all plants which are not true to name, and all materials which do not comply with the specified requirements.
  3. Use all means necessary to protect plant materials before, during, and after installation and to protect the work and materials of all other trades.
- B. Replacements: In the event of damage, immediately make all repairs and replacements necessary to the recommended approval of the Landscape Architect and at no additional cost to the City.

## 1.9 RESPONSIBILITY AND COORDINATION DURING WEED ABATEMENT

- A. During Weed Abatement procedures, the Landscape Contractor is responsible for the erection of all signs and barriers required to prevent intrusion into the treated areas and to notify the public.
- B. No material or methods used for Weed Abatement shall affect the landscape planting or hydroseed germination. No material or method shall render the job site unusable for more than ten (10) days from date of application.

## PART 2 - MATERIALS

- A. All materials shall conform to the requirements of Section 212 of the Standard Specifications, except as modified herein.

### 2.2 LANDSCAPE FINISH GRADING

- A. Site topsoil material - No import soil.

### 2.3 NON-SELECTIVE HERBICIDES

- A. Non-selective contact herbicide and/or non-selective systemic herbicides (as recommended by the Pest Control Advisor).

### 2.4 SELECTIVE HERBICIDES

- A. Selective pre-emergent herbicides ('Ronstar G' or equal or as recommended by the Pest Control Advisor).

### 2.5 SOIL CONDITIONERS AND FERTILIZERS

- A. Soil conditioners may include any or all of the conditioners herein specified and shall be applied at rates indicated on the plans or as determined by the Agronomical Soils Report.

#### **SoilPro Products Compost**

##### Available from:

Inland Empire Regional Composting Authority  
12645 Sixth Street  
Rancho Cucamonga, CA 91739

909-993-1500

## 2.6 PLANTING TABLETS

- A. Fertilizer planting tablets shall be tightly compressed commercial grade planting tablets having a 12-8-8 formula, weighting 7 grams each, as "Gro-Power" planter tablets or equal. The planting tablets shall be delivered to the site in the original, unopened containers, bearing the manufacturer's guaranteed analysis. Any damaged tablets will not be accepted.

## 2.7 PLANT MATERIALS

- A. Nomenclature: The scientific and common names of plants herein specified conform to industry standards. (Refer to list of plant materials on Drawings).
- B. Labeling: Each group of plant materials delivered to the site shall be clearly labeled as to species and variety and nursery source.
- C. Quality and Size:
1. Plants shall be in accordance with the California State Department of Agriculture's regulation for nursery inspections, rules and grading. All plants shall have a normal habit of growth and shall be sound, healthy, vigorous, and free of insect infestations, plant diseases, sun scalds, fresh abrasions of the bark, excessive abrasions, or other objectionable disfigurements. All plants shall have normally well-developed branch system, with vigorous and fibrous root systems which are not root or pot bound. In the event of disagreement as to condition of the plants furnished by the Contractor in containers will be determined by removal of earth from the roots of not less than two plants or more than 2% of the total number of plants of each species or variety. Where container grown plants are from several sources, the roots of not less than two plants of each species or variety from each source will be inspected. In case the sample plants reviewed are found to be defective, the Landscape Architect and the City may judge acceptability. Any plants rendered unsuitable for planting because of this review will be considered as samples and will be provided at the expense of the Contractor.
  2. The size of the plants will correspond with that normally expected for species and variety of commercially available nursery stock, or as specified in the special Conditions or Drawings. The minimum acceptable size of all plants measured before pruning with the branches in normal position, shall conform with the measurements, if any, specified on the Drawings in the list of plants to be furnished. Plants larger in size than specified may be used with the recommended approval of the Landscape Architect, but the use of larger plants will make no change in contract price. If the use of larger plants is recommended for approval, the ball of earth or spread of roots for each plant shall be increased proportionately.
  3. Rejection or Substitution: All plants not conforming to the requirements herein specified shall be considered defective, and such plants, whether in place or not, shall be marked as rejected and immediately removed from the site of the work and replaced with new plants at the contractor's expense. The plants shall be of the species, variety, size and condition specified herein or shown on the drawings. Under no condition will there be any substitution of plants or sizes for those listed on the accompanying plans, except with the expressed consent of the Landscape Architect.
  4. Pruning: At no time shall the tree or plant materials be pruned, trimmed or topped prior to delivery, and any alteration of their shape shall be conducted only with the recommended approval and when in the presence of the Landscape Architect.



5. Protection: All plants at all times shall be handled and stored so that they are adequately protected from drying out, from wind burn, or from any other injury.
6. Right of Review: The Landscape Architect reserves the right to recommend approval or rejection at any time upon delivery or during the work, any or all plant material regarding size, variety or condition.

## 2.8 SODDED TURF

- A. Sod type shall match existing turf. Submit product information to city for approval.

## PART 3 - EXECUTION

Installation shall conform to the requirements of Section 308 of the "Standard Specifications," except as modified herein.

### 3.1 GENERAL

- A. Prior to the start of work of this Section, all trash and deleterious materials on the surface of the ground shall be removed and legally disposed of.

### 3.2 WEED ABATEMENT

- A. Prior to the installation of the irrigation system, all weed growth shall be removed within the areas designated to be cleared and grubbed. Refer to plans for limit of work.
  1. If in the opinion of the Pest Control Advisor, perennial grasses and weeds existing in the planting areas will require control prior to removal, spray these areas per Pest Control Adviser's recommendations. Allow herbicide to kill all weeds. Rake or hoe off all dead weeds to a depth of one to two inches (1" to 2") below the surface of the soil. Physically remove all weeds from the site.
- B. Upon completion of the irrigation system and rototilling of soil amendments into the soil and immediately preceding the installation of plant material, perform weed abatement as follows, and per Pest Control Advisors recommendation.
  1. Apply Sulfate of Ammonia at the rate of five pounds (5 lbs.) per one thousand square feet (1,000 sf.) to all planting areas.
  2. Irrigate area for fourteen (14) consecutive days, to germinate existing weed seeds.
  3. Apply by spray a non-selective herbicide to eradicate all existing weeds. Do not irrigate for seven (7) days after application.
  4. Remove weeds after herbicide has had time to sufficiently kill. Remove all dead weeds by rake or hoe to a depth of one to two inches (1" to 2") below the surface of the soil. Remove all weed residue and top growth and dispose of in a legal manner.

### 3.3 SOIL PREPARATION AND FINE GRADE

- A. Soil Preparation: Prior to spreading soil amendments and prior to installation of irrigation systems, cross-rip or otherwise till to a depth of ten inches (10") all planting areas to receive soil preparation. All rock one inch (1") and larger shall be removed to a depth of twelve inches (12"). Dispose of all debris off-site in a legal manner.

- B. Planting Areas: To all planting areas (turf, shrub and groundcover), uniformly broadcast soil amendments and thoroughly incorporate to a minimum six inch (6") depth by means of a rototiller or equal.
- C. Soil Amendments are to be thoroughly incorporated at the following rates per one thousand square feet (1,000 sf.) by rototilling or other approved method:
  - 1. 3 cu. yds. SoilPro
    - a. (Mix to be used for bidding purposes only, to be verified with Agronomical Soils Test.)
- D. Finish Grade:
  - 1. Rough grade has been left within one tenth (1/10) of one foot (1') of finish grade.
  - 2. Work such as fine grading and light cultivation are required of all planting areas indicated on plan to prepare grades prior to planting.
  - 3. After approximate finished grades have been established, all soil areas shall be compacted and settled by application of heavy irrigation to a minimum depth of twelve inches (12").

### 3.4 FINAL GRADES

- A. After the foregoing specified deep watering, minor modifications to grade may be required to establish the final grade. These areas shall not be worked until the moisture content has been reduced to a point where working it will not destroy soil structure.
- B. Finish grading shall ensure proper drainage of the site.
- C. Finished surfaces shall be smooth and even between contours; shapes shall be to the satisfaction of the Landscape Architect.
- D. All areas shall be graded so the final grades will be one inch (1") below adjacent paved areas, sidewalks, valve boxes, clean-outs, drains, manholes, etc.
- E. Surface drainage shall be away from all building foundations.
- F. Eliminate all erosion scars.
- G. The Contractor shall request a review by the Landscape Architect for recommended approval of the final grades and elevations before beginning planting operations.

### 3.5 SODDED TURF

- A. Turf grass shall be planted by sod laying.
- B. Sodding - irrigate areas to be sodded prior to installation. Moisture shall be uniformly present to a depth of 2". Sod shall be installed within one day of delivery, rolls shall be placed in shaded areas prior to installation. Sod shall conform to all lawn shapes as designated per plan and shall be installed in such a manner as to visually eliminate all joints and edges of sod strips. Following installation, irrigate turf areas thoroughly to provide even moisture penetration. Roll all sod prior to beginning installation within two (2) hours - prior to beginning irrigation, sod shall be uniformly smooth in appearance and shall be flush with the finished grade of all walks, curbs, etc.
- C. Maintenance - three (3) weeks following installation of turfgrass, areas shall be mowed regularly at intervals not exceeding once per week. Mowing shall be done with sharp, well adjusted mowers or cut more than half the existing top growth in one mowing. Mowing heights shall be 2" to 2 1/2",

during hot weather seasons never less than 2" and shall be 1 1/2" TO 2" during cool weather seasons. Turfgrass areas that do not properly grow shall be resodded as necessary. At the termination of the maintenance period all turfgrass areas shall be completely covered, leaving not barren spots larger than three inches (3") x three inches (3").

### 3.6 WATERING

- A. Apply water to all planted areas during operations and thereafter, until acceptance of the work.
- B. Immediately after planting, apply water to each shrub by means of a hose. Apply water in a moderate stream in the planting hole until the material about the roots are completely saturated from the bottom of the hole to the top of the ground.
- C. Apply water in sufficient quantities and as often as seasonal conditions require to keep the planted areas sufficiently moist at all times, well below the root system of grass and plants.
- D. All turf and groundcover areas shall be kept damp at all times and irrigation should be adjusted accordingly. This normally would involve four (4) to six (6) watering periods daily, each watering period (ON) regulated to just dampen the mulch without creating run off.
- E. Intervals between irrigation (OFF) sequence should be judged by the length of the time mulch remain damp. Once the mulch begins to dry out, the water (ON) sequence should be repeated.

### 3.7 ESTABLISHMENT AND MAINTENANCE PERIOD

- A. The Contractor shall continuously maintain all areas involved in this contract during the progress of the work and during the establishment and maintenance period until final acceptance of the work by the City.
- B. Plant establishment period: The contractual establishment period shall be for no less than thirty (30) continuous calendar days. The contractual establishment period begins on the first day after all planting in this project is completed and accepted and the planted areas are brought to a neat, clean and weed free condition.
  1. Any day upon which no work will be required, as determined by the Landscape Architect, will be credited as one of the plant establishment working days regardless of whether or not the Contractor performs plant establishment work.
  2. Any day when the Contractor fails to adequately maintain plantings, replace unsuitable plants or do weed control or other work, as determined necessary by the Landscape Architect, will not be credited as one of the plant establishment working days.
  3. In order to carry out the plant establishment work, the Contractor shall furnish sufficient men and adequate equipment to perform the work during the plant establishment period.
  4. Improper maintenance or possible poor condition of any planting at the termination of the scheduled establishment period may cause postponement of the final acceptance of Plant Establishment. Contractor shall bear all costs for extension of the Plant Establishment period.
- C. Plant Maintenance Period: The contractual maintenance period shall be no less than ninety (90) continuous calendar days, and shall begin at the acceptance of the Plant Establishment Period.
  1. All areas shall be kept free of debris, and all planted areas shall be weeded at intervals of not more than ten (10) days. Watering, trimming, fertilization, spraying and pest control, as may be required, shall be included in the maintenance period. Maintenance shall include pest control (squirrel, gopher, rabbits, etc.).

2. Post fertilize all turf areas at the end of every 30 days (of maintenance) at the rate of five pounds (5 lbs.) per one thousand square feet (1,000 s.f.) using ammonium sulfate, evenly applied and thoroughly watered in. Post fertilize all groundcover areas at the end of every thirty (30) days (of maintenance) at the rate of thirty pounds (30 lbs.) per one thousand square feet (1,000 s.f.), using 5-3-1 Gro-Power. For the final feeding of all areas, use 12-8-8 Gro-Power Controlled Release Nitrogen at the rate of thirty pounds (30 lbs.) per one thousand square feet (1,000 s.f.).
3. Mowing of turf will commence when turf grass has reached a height of one and one-half inches (1 1/2"). Turf shall be cut with a reel type mower at a one (1) inch height. Mowing will be at least weekly after the first cut. Turf must be well established and free of bare spots and weeds to the satisfaction of the Landscape Architect prior to final acceptance by the City. Excess grass clippings, as determined by the Landscape Architect, shall be picked up and removed from the site and premises.
4. The Contractor shall maintain the irrigation systems in a like new operating condition; adjusting head heights and spray arcs as necessary. The Contractor is responsible for proper watering of all planting areas, for providing any necessary supplemental water as may be required, and shall replace any material damaged due to improper moisture.
5. During the maintenance period, the Contractor shall be responsible for maintaining adequate protection for all planting areas. Any damaged areas shall be repaired and any plant materials replaced at the Contractor's expense.
6. The Contractor's maintenance period will be extended past ninety (90) days if these provisions are not filled.

### 3.8 GUARANTEE AND REPLACEMENT

- A. All plant material installed under the contract shall be guaranteed against any and all poor, inadequate or inferior materials and/or workmanship for a period of one (1) year. Any plant found to be dead or in poor condition due to such faulty materials or workmanship, as determined by the Landscape Architect, shall be replaced by the Contractor at his expense.
- B. All palms shall be guaranteed by the contractor for twenty-four (24) months after final acceptance of the project. Contractor liability shall cover cost of labor, equipment, and materials to replace trees of similar size during the covered period.
- C. Any material found to be dead, missing, or in poor condition during the establishment period shall be replaced immediately. The Landscape Architect shall be the judge as to the condition of material. Material to be replaced within the guarantee period shall be replaced by the contractor within fifteen (15) days of written notification by the City.
- D. Replacement shall be made to the same specifications required for original plantings within five (5) working days after written notification.
- E. Material and Labor involved in the replacing of material shall be supplied by the Landscape Contractor at no additional cost to the City.

### 3.9 REVIEWS

- A. Normal progress reviews shall be requested from the Landscape Architect at least forty-eight (48) hours in advance of an anticipated inspection. A review will be made by the Landscape Architect on each of the steps listed below. The Contractor will not be permitted to initiate the succeeding steps of work until he has received written recommendation of approval to proceed by the Landscape Architect.
  1. Immediately prior to the commencement of the work on this Section.

2. Preparation of areas of turf installation.
3. Final review, start of establishment & maintenance period.
4. After thirty (30) day plant establishment & maintenance.
5. Final acceptance of project/ninety (90) day maintenance.

### 3.10 PAYMENT TERMS

- A. Payment for planting work will be at the lump sum price bid for planting. Payment shall include full compensation for furnishing all labor, materials, tools, equipment, and incidentals, and for doing all the work in planting as herein specified. A 10% retention shall apply to all planting work.

**END OF SECTION**

## SECTION 03100 - CONCRETE FORMWORK

### PART 1 - GENERAL

#### 1.1 RELATED DOCUMENTS

- A. The provisions of the "Standard Specifications for Public Works Construction," latest edition, Section 302-6, shall apply except as modified herein.

#### 1.2 SCOPE

- A. Work of this Section includes all materials, labor and equipment necessary for and incidental to completing the Concrete Form work, as shown on the Drawings, as reasonably implied, or as specified herein, including, but not limited to, the following:
1. Forms for all concrete.
  2. Shoring and bracing.
  3. Setting of embedded items.
  4. Removal of forms.

#### 1.3 RELATED WORK SPECIFIED ELSEWHERE

|                         |               |
|-------------------------|---------------|
| Concrete:               | Section 03300 |
| Concrete Reinforcement: | Section 03200 |

#### 1.4 STANDARDS

- A. Materials and workmanship shall conform to the requirements of all applicable building codes, except that requirements specified herein shall govern where they exceed those in the Building Code. Refer and comply with the provisions of the following codes, specifications and standards, except as otherwise shown or specified:

American Concrete Institute, ACT 347, "Recommended Practice for Concrete Form work."

#### 1.5 QUALITY ASSURANCE

- A. Provide all openings in concrete Form work to accommodate work of other trades; accurately determine size and location of openings, recesses, etc., from trades providing or requiring such items; place items required for incorporating into concrete accurately and securely supported on forms.
- B. Base form and false work design on required values of live and dead loads, weight of moving equipment on Form work, height of concrete drop, foundation pressures, stresses, lateral stability and other safety factors required during construction.
- C. Materials used in Form work may not be reused except for use in other forms, without the Landscape Architect's recommended approval.

- D. Contractor shall verify drawing dimensions with actual field conditions. Inspect related work and adjacent surfaces. Report to the Landscape Architect all conditions which prevent proper execution of this work.
- E. Use various form types as specified below. Refer to Concrete Section 03300 and use form materials for best results. All forms shall have a smooth straight upper edge and shall be free of any warping.

## **PART 2 - MATERIALS**

All materials shall conform with Section 204 of the Standard Specifications except as modified herein.

### **2.1 FORM COATINGS**

- A. Non-grain-rising and non-staining type that will not leave residue on surface of concrete or adversely affect bonding to concrete of paint, plaster, mortar or other applied materials. Coatings containing mineral oils or other non-drying ingredients will not be permitted. Submit manufacturer's data.

### **2.2 LUMBER**

- A. Lumber shall be "Construction Grade" Douglas Fir.

### **2.3 PLYWOOD**

- A. Plywood shall be of grade Exterior B-B. All plywood shall be at least 5/8" thick, and edge sealed. Plywood for forming exposed concrete shall be Plyform.

### **2.4 METAL FORMS**

- A. Removable metal forms shall be of proper gauges and sizes, carefully aligned and fitted. Removable metal forms shall be properly reconditioned for use, clean, free from dents, bends, rust, oil or other coatings, and shall receive the recommended approval of the Landscape Architect prior to installation.

### **2.5 FORM TIES**

- A. Prefabricated rod, flat band or wire type, or threaded internal disconnecting type of sufficient tensile strength to resist all imposed loads of fresh concrete and with external holding devices of adequate bearing area. Ties shall permit tightening and spreading of forms and leave no metal closer than one and one-half inches (1-1/2") from surfaces.

### **2.6 FORM TYPES**

- A. Use Plywood or Metal Forms as specified above for exposed surfaces.
- B. Use Boards or Plywood as specified above for concealed surfaces.

## PART 3 - EXECUTION

### 3.1 GENERAL

- A. Build forms to exact shapes, sizes, lines and dimensions as required to obtain accurate alignment, locations and grades, and level and plumb work. Provide for openings, offsets, keyways, recesses, chamfers, blocking, joint screeds, anchorages and other required features.
- B. Use metal spreaders to provide accurate spreading of forms and positive tying of forms together.
- C. Provide for recesses, rebates, drips and profiles as detailed.
- D. Forms shall be of materials and construction adequate to safely support all loads, so that no sagging, leakage or displacement occurs during and after pouring of concrete.
- E. Form joints shall not show in exposed concrete.
- F. Clean-outs and Cleaning - Provide temporary openings in wall and column forms for cleaning and inspection. Prior to pouring, clean all forms and surfaces to receive concrete.
- G. Provide 3/8" x 3/8" chamfer strips for exposed corners unless otherwise indicated. Use eight feet (8') long plywood for exposed surfaces.
- H. Fabricate form for easy removal without hammering or prying against the concrete surfaces. Provide crush plates or wrecking plates where stripping may damage cast concrete surfaces. Provide top forms for inclined surfaces where slope is too steep to place concrete with bottom forms only.
- I. Forms shall be set with the upper edge of the board true to line and grade and shall be staked rigidly in place with stakes set not more than four feet (4') apart.
- J. Thoroughly clean forms and adjacent surfaces to receive concrete. Remove chips, wood, sawdust, dirt and all other debris just before concrete is placed. Re-tighten forms during and after concrete placement if required to eliminate mortar leaks.
- K. Clean and repair surfaces for forms to be reused in the work. Split, frayed, delaminated or otherwise damaged form facing material will not be acceptable. Apply new form-coating compound material to concrete contact form surfaces.
- L. When forms are extended for successive concrete placement, thoroughly clean surfaces, remove pins and tighten form to close joints. Align and secure joints to avoid offsets. Do not use "patched" forms for exposed concrete surfaces. Forms are to be inspected prior to pouring concrete.

### 3.2 FORM COATINGS

- A. Coat the contact surfaces of forms with a form-coating compound before reinforcement is placed. Provide commercial formulation form-coating compounds that will not bond with, stain, nor adversely affect concrete surfaces, and will not impair subsequent treatments of concrete surfaces requiring bond or adhesion, nor impede wetting of surfaces to be cured with water or curing compound.
- B. Thin form-coating compounds only with thinning agent of type, and in amount, and under conditions of the form-coating compound manufacturer's directions. Do not allow excess form-coating material to accumulate in the forms or to come into contact with concrete surfaces against which fresh concrete will be placed. Apply in compliance with manufacturer's instructions.



### 3.3 REGRETS & REBATES

- A. Each affected trade required to fasten work to the structure, or to insert therein any piping, conduit, duct, box bolt, anchor, insert or other rough hardware, shall set such items securely and accurately in the forms. Be responsible for any and all changes in such piping, box, bolt, anchor, inserts and other rough hardware after they have been set in the forms.
- B. Conduits and pipes in concrete slabs will be permitted to be embedded therein under the following conditions:
  - 1. Conduit or pipe diameter shall not exceed one-third (1/3) of the slab thickness
  - 2. Minimum spacing of conduit or pipe shall be three (3) diameters
  - 3. There shall be a minimum separation of one inch (1") from parallel reinforcing steel and conduit
  - 4. Minimum concrete coverage over conduits and pipes shall be one inch (1")
  - 5. No crossovers will be permitted except as specifically detailed
  - 6. No reinforcing steel shall be bent or displaced to permit passage of conduit or pipe
  - 7. No conduit or pipe shall be placed in slabs four and one-half inches (4-1/2") and less in thickness, unless specifically detailed or specifically authorized by the Landscape Architect
- C. Build into forms special features as the character and requirements of work dictate.
- D. Place pouring strips in the forms wherever horizontal construction joints are made in exposed concrete. Place pouring strips level and place concrete flush with the top of the pouring strip. After cleaning concrete surfaces and just ahead of placing of subsequent concrete, tighten form ties to conceal shrinkage.
- E. Carefully check with other trades before completing forms and placing concrete to determine all embedded items are in place in the forms. Set miscellaneous anchors, bolts, ties, dowels, plates, etc. necessary to complete the work as detailed. Embed no wood blocks other than treated built-in blocks or nailing blocks in concrete.

### 3.4 FORM REMOVAL

- A. Remove forms only when concrete has developed sufficient strength to sustain its own weight and super-imposed loads.

### 3.5 PAYMENT TERMS

- A. Payment for concrete formwork will be at the lump sum price bid for concrete. Payment shall include full compensation for furnishing all labor, materials, tools, equipment, and incidentals, and for doing all the work in concrete formwork as herein specified. A 10% retention shall apply to all concrete work.

### END OF SECTION

## SECTION 03200 - CONCRETE REINFORCEMENT

### PART 1 - GENERAL

#### 1.1 RELATED DOCUMENTS

- A. The provisions of the "Standard Specifications for Public Works Construction," latest edition, Section 201-2, shall apply except as modified herein.

#### 1.2 SCOPE OF WORK

- A. Work of this Section includes all material, equipment, and labor necessary for and incidental to completing all Concrete Reinforcement, as shown on the Drawings as reasonably implied, or as specified herein, including, but not limited to, the following:
1. Reinforcing steel.
  2. Control during concrete placement.

#### 1.3 RELATED WORK SPECIFIED ELSEWHERE

- A. Concrete: Section 03300

#### 1.4 STANDARDS

- A. Materials and workmanship shall conform to the requirements of all applicable building codes, except that requirements specified herein shall govern where they exceed those in the Building Code. Refer and comply with the provisions of the following codes, specifications and standards, except as otherwise shown or specified.
1. American Concrete Institute, ACI 318, "Building Code Requirements for Reinforced Concrete."
  2. Concrete Reinforcing Institute, "Manual of Standard Practice."
  3. American Concrete Institute, ACI 315, "Manual of Standard Practice for Detailing Reinforced Concrete Structures."
  4. American Welding Society, AWS D12.1, "Recommended Practices for Welding Reinforcing Steel, Metal Inserts and Connections in Reinforced Concrete Construction."

#### 1.5 INSPECTION

- A. Contractor shall notify the City and Landscape Architect prior to pouring of concrete in order to inspect placement of all reinforcement.

#### 1.6 TESTING

- A. Tests will be conducted as required by the City and in accordance with Section 201-2.5 of the Standard Specifications.

**PART 2 - MATERIALS****2.1 REINFORCING STEEL BARS**

- A. Shall be deformed steel bars conforming to ASTM A-615 and UBC Standard 26-4, and shall be Grade 40 or Grade 60. Refer to Section 201-2.2 of the Standard Specifications.

**2.2 WELDED WIRE FABRIC**

- A. Conform to ASTM A 185 and Standard Specifications, Section 201-2.4.

**2.3 TIE WIRE**

- A. Annealed steel, 16-gauge minimum, galvanized where concrete is exposed.

**2.4 SUPPORTS FOR REINFORCING**

- A. All supports for work exposed to view or weather shall be galvanized steel, or plastic-coated units so that finished surfaces will not be marred nor stained; supports shall be suitably sized and spaced for proper load distribution on earth or membrane so that membrane is not perforated and rebar does not set. Use no supports of wood or other cellulose material.

**PART 3 - EXECUTION**

- A. All work shall conform to the requirements of Section 303-1.7 of the Standard Specifications.

**3.1 GENERAL**

- A. Coordinate with other trades and expedite materials and labor to avoid omissions and delay in job progress.
- B. Clean reinforcement of loose mill scale, oil or other foreign coatings that might destroy or reduce bond prior to placement of concrete or grout.

**3.2 FABRICATION AND DELIVERY**

- A. Fabricate bars of indicated size and accurately form to shapes and lengths indicated and required, by methods not injurious to materials. Do not heat reinforcement for bending. Bars with bends or offsets not conforming to Drawings will be rejected.
- B. Bundle reinforcement and tab with suitable identification to facilitate sorting and placing and sufficient supply of proper reinforcement at site to avoid delays; transport and store at site so as not to damage material.

### 3.3 SECURING IN PLACE

- A. Accurately place reinforcement and securely wire tie in precise position at points where bars cross. Tie stirrups to bars at both top and bottom. Bend wire ties away from forms. Use galvanized wire ties in exterior walls, beams, columns, and slabs. Support horizontal bars in strict accordance with the "Manual of Standard Practice," latest edition, published by concrete Reinforcing Steel Institute.
- B. Maintain proper placement of all reinforcement during entire pouring or grouting operation.

### 3.4 PLACING REINFORCING BARS

- A. Splice reinforcement as indicated on the Drawings and as specified herein. Avoid splices at critical connection and stress points. Lap as indicated or necessary to develop full strength or stress of bars. Stagger top splices and in horizontal wall reinforcement separate at least ten feet (10') longitudinally in alternate bars of opposite tiers. Extend stubs and dowel required to receive and engage subsequent work as sufficient length to develop full strength of bar or as indicated. Place dowel and stub bar in forms, and maintain placement during pouring of concrete or grout.
- B. Where reinforcement is interrupted by sleeves and openings, provide additional bars as indicated on the Drawings.
- C. When necessary, perform welding of reinforcing bars in accordance with "Recommended Practices for Welding Reinforcing Steel, Metal Inserts and Connections for Reinforced Concrete Construction" (AWSD12.1).

### 3.5 PLACING FABRIC REINFORCEMENT

- A. Roll out, straighten, cut to required size, and lay reasonably flat in place. Lap fabric one full mesh at sides and ends; securely wire together and to other reinforcement at frequent intervals.

### 3.6 CLEARANCES

- A. Exercise particular care to maintain proper distance and clearance between parallel bars and between bars and forms. Provide metal spreaders and spacers to hold steel in position as necessary. Use metal or plastic chairs to support reinforcing steel and mesh in concrete placed on earth and in footings. Transverse steel bars with hangers, or in another manner, as necessary.
- B. Minimum clear distances between reinforcing steel and face of concrete shall be as indicated on the Drawings, or as follows:
  1. Concrete footings formed against earth 3"
  2. Concrete in forms with exposed faced in contact with earth 2"
  3. Walls As detailed
  4. Slabs Centered

**3.7 PAYMENT TERMS**

- A. Payment for concrete reinforcement will be at the lump sum price bid for concrete. Payment shall include full compensation for furnishing all labor, materials, tools, equipment, and incidentals, and for doing all the work in concrete reinforcement as herein specified. A 10% retention shall apply to all concrete work.

**END OF SECTION**

**SECTION 03300****CONCRETE****PART 1 - GENERAL****1.1 RELATED DOCUMENTS**

- A. The provisions of the "Standard Specifications for Public Works Construction," latest edition, shall apply except as modified herein.

**1.2 SCOPE OF WORK**

- A. Work of this Section includes all material, equipment, and labor necessary for and incidental to completing all Concrete Work, as shown on the Drawings, as reasonably implied, or as specified herein, including, but not limited to, the following:
- Exterior walks and slabs as shown on Drawings.
  - Curbs, gutters, and mowing curbs.
  - Cast-in-place concrete.
  - Miscellaneous concrete items.
  - Setting of items to be inserted into concrete.
  - Cement, finish, joints, saw cutting, and patching.
  - Curing.
  - Testing.

**1.3 RELATED WORK SPECIFIED ELSEWHERE**

|                         |               |
|-------------------------|---------------|
| Irrigation:             | Section 02441 |
| Concrete Form work:     | Section 03100 |
| Concrete Reinforcement: | Section 03200 |

**1.4 STANDARDS**

- A. Testing, materials and workmanship shall conform to the requirements of all applicable building codes, except that requirements specified herein shall govern where they exceed those in the Building Code.

**1.5 SMOOTHNESS TOLERANCE**

- A. Cement finish surfaces shall be of such smoothness and evenness that they shall contact the entire length of a ten foot (10') straight edge laid in any direction, with an allowable tolerance of one-eighth inch (1/8"). Any operations necessary to achieve this result shall be performed by the Contractor at no additional cost to the City.
- B. No patching will be permitted to correct defective work; defective Sections shall be removed to the nearest score line or construction joint and replaced. No extension of time will be allowed for correcting defective work.

**1.6 INSPECTIONS**

- A. Inspections will be required. Contractor shall call for inspection a minimum of forty-eight (48) hours (two working days) prior to need.
1. The Contractor shall call for inspection upon completion of each of the following specific phases of construction, each prior to pour:
    - a. All form work placement/construction.
    - b. All footing excavation.
    - c. Sub-grade preparation.
    - d. Steel reinforcing placement.
- B. Any work covered prior to inspection shall be opened to view by the Contractor at his expense.

**1.7 TESTING**

- A. All testing shall be as required by the "Standard Specifications."

**PART 2 - MATERIALS**

- A. All materials shall conform to Section 201-1.2 of the "Standard Specifications."

**2.2 CONCRETE**

- A. Concrete shall be a Class 560C-3250, minimum six (6) sack mix, with a maximum four inch (4") slump, 3,250 pounds per square inch ultimate compressive strength at twenty-eight (28) days and shall conform to Concrete Class Use Table, Section 201-1, of the Standard Specifications. No Fly Ash shall be incorporated into the mix.

**2.3 ADMIXTURE:**

- A. Admixture shall be WRDA® 64, a polymer based aqueous solution which produces a concrete with lower water content, greater plasticity and higher strength, as manufactured by Grace Construction Products, or equal. The admixture shall not contain calcium chloride and shall comply with ASTM Designation C494, Type A water-reducing (or Type D water-reducing and retarding) admixtures.

**2.4 REINFORCING STEEL**

- A. Shall be in accordance with Section 03200, Concrete Reinforcement and per Section 201-2 of the "Standard Specifications."

**2.5 EXPANSION JOINTS**

- A. Expansion joint material shall be foam material "Flexcell" as manufactured by Celotex Corporation, conforming with ASTM Standard D1751-61, "Fleximastic," conforming to ASTM D1190, or approved equal. Only one type of material to be used throughout the job. Submit samples of preformed materials for approval of the City.

**2.6 SCORE JOINTS**

- A. Shall be as shown on the Drawings and details.

**2.7 CONCRETE CURING COMPOUND**

- A. Shall be Type 1 - in conformance with Section 201-4 of the "Standard Specifications."

**2.8 FORM LUMBER**

- A. Shall be Douglas Fir, construction grade or better, in conformance with Section 303-1.3 of the "Standard Specifications."

**PART 3 - EXECUTION**

- A. All work shall conform to the requirements of Section 303 of the "Standard Specifications."

**3.1 GENERAL**

- A. The Contractor shall provide copies of all load tickets for all transit-mixed concrete delivered to the site.
- B. All concrete slabs shall slope to drain. Depressions in the slab surface that hold water ("bird baths") will not be acceptable.
- C. Install concrete and cement finish work true to lines, dimensions and grades.
- D. Protect all finished concrete from graffiti. The Contractor shall provide watchmen as required to insure a graffiti-free surface. Stoning and/or patching of concrete surfaces will not be permitted. Whole sections must be removed and replaced. A graffitied finish will not be acceptable.
- E. Remove and replace all defective concrete and defective cement finish work. All concrete with cracks shall be deemed unacceptable and the full panel shall be removed and replaced at the Contractor's sole expense. Permission to patch any defective area shall not be a waiver of the City's right to require complete removal of defective work if patching does not restore quality and appearance of work.
- F. No advertising impression, stamp, or mark of any description will be permitted on surface of concrete or cement finish.
- G. Concrete shall be poured prior to 11:00 a.m. Contractor is to guarantee curing of concrete free of graffiti.

**3.2 PLACING CONCRETE**

- A. Before placing of any concrete, thoroughly clean all forms, washout with water and make tight. Transport, place and spread concrete in a manner to prevent segregation of aggregate. Reinforcing shall be supported by metal or plastic chairs; concrete supports shall not be used. Refer to Sections 303-1.7 and 303-1.8 of the "Standard Specifications."



### 3.3 CEMENT FINISH

- A. Exterior slabs and walks-non-slip, uniform light broom surface, transverse to direction of slab, unless otherwise shown on the plans. Finish cast-in-place walls as designated on details.

### 3.4 CURING

- A. Initial curing shall be moist curing or moisture cover curing, and shall continue for at least 168 cumulative hours (not necessarily consecutive), during which the concrete has been exposed to air temperatures above 50 Degrees F. Avoid rapid drying at the end of the curing period.
- B. Use water that is free of impurities which could etch or discolor concrete surfaces.

**Do not use liquid membrane curing compounds on surfaces which are to be covered with a coating material applied directly to the concrete or with a covering material bonded to the concrete, such as other concrete, liquid floor hardener, water-proofing, damp-proof flooring, painting, court surfacing materials and other coatings and finish materials, unless otherwise acceptable to the inspector.**

### 3.5 COORDINATION

- A. All site furnishings, benches, drinking fountains, light poles, etc. shall be set in cured footings prior to placing concrete slabs. All foundations shall cure at least fourteen (14) days prior to placing concrete slabs.

### 3.6 PAYMENT TERMS

- A. Payment for concrete work will be at the lump sum price bid for concrete. Payment shall include full compensation for furnishing all labor, materials, tools, equipment, and incidentals, and for doing all the work in concrete as herein specified. A 10% retention shall apply to all concrete work.

**END OF SECTION**

**SECTION 03 10 00 – CONCRETE FORMING FOR SKATEPARKS****PART 1 - GENERAL**

## 1.1 DESCRIPTION

- A. Construct all formwork to follow skatepark drawings, unless otherwise approved by the engineer/architect. Construct formwork to allow for removal without damaging finished concrete surfaces.

## 1.2 RELATED SECTIONS:

- A. SECTION 03 20 00 - CONCRETE REINFORCING FOR SKATEPARKS
- B. SECTION 03 30 00 - CAST-IN-PLACE CONCRETE FOR SKATEPARKS
- C. SECTION 03 39 00 – CONCRETE CURING FOR SKATEPARKS

**PART 2 – PRODUCTS**

- A. Form materials: plywood, metal, metal-framed plywood, or other approved panel-type materials free from defects and distortion, and to provide full-depth, continuous, straight, smooth exposed surfaces.
- B. Use flexible or curved forms as required to provide vertical and horizontal radii as indicated in the drawings.
- C. Provide 2” nominal thickness, surfaced plank wood forms for straight sections. Use flexible metal, 1” lumber, or plywood forms for radius bends. Do not overlap forms, creating an offset finished edge.
- D. Form-release agent: commercially formulated form-release agent that will not bond with, stain, or adversely affect concrete surfaces and will not impair subsequent treatments of concrete surfaces.

**PART 3 - EXECUTION**

- A. Edge forms and screed construction
  - i. Set, brace, and secure edge forms, bulkheads, and intermediate screed guides for pavement to required lines, grades, and elevations. Install forms to allow continuous progress of work.
- B. Do not overlap forms, creating an offset finished edge.
- C. Clean forms after each use and coat with form release agent to ensure separation from concrete without damage.

END OF SECTION

## SECTION 03 12 00 – EARTH MOVING FOR SKATEPARKS

### PART 1 - GENERAL

#### 1.1 SUMMARY

- A. Perform all earthwork for skatepark items as indicated on the construction drawings and specified in the contract documents.

#### 1.2 SCOPE OF WORK

- A. Furnish materials, labor, transportation, services, and equipment necessary to perform all earthwork operations related to the skatepark as indicated on the construction drawings. Complete as shown and as specified herein.

#### 1.3 QUALITY ASSURANCE

- A. Testing services: coordinate the following testing with the owner retained testing agency (if required by the project standard specifications):
  - i. Material evaluations tests for aggregate base, subgrade, and imported structural fill.
  - ii. Inspection of structural fill placement and compaction.
  - iii. Inspection of final subgrade.
  - iv. Base material compaction test for every 1000 s.f. of concrete flatwork in skatepark area to ensure 95% compaction in accordance with civil engineering specifications and testing agency recommendations.
- B. The earthwork shall be done under supervision of a soils engineer retained by the owner (if required by the project), who shall verify earthwork specifications for the support of slab on grade and for the control of soil swelling. Field density tests to determine the level of compaction being achieved in the fill shall be performed on each lift at the beginning of fill placement and at a frequency mutually agreed upon by the project team for the remainder of the project.
- C. A soils report may not exist for this project. Owner shall retain a soils engineer (if so required by the project) to verify excavations for assumed allowable soil bearing, low settlement and swell potential, and to make any additional recommendations.

#### 1.4 PROJECT CONDITIONS

- A. Existing conditions: the existing topographic conditions are shown on the drawings for reference only.
- B. Upon beginning the earthwork, contractor represents that he has inspected the site and satisfied himself as to actual grades and levels and the true conditions under which the work is to be performed.
- C. Promptly notify the owner's representative of unexpected subsurface conditions.

#### 1.5 PROTECTION

- A. maintain benchmarks, monuments, and other reference points. If disturbed or destroyed, replace as directed.
- B. Protect excavations by shoring, bracing, sheeting, underpinning, or other methods, as required to prevent cave-ins or loose dirt from entering excavations. Barricade open excavations adjacent to public streets and walks.
- C. Cover holes and trenches when work is not in progress.
- D. Promptly repair damage to adjacent facilities caused by earthwork operations. Cost of repair at contractor's expense.

## 1.6 REFERENCE STANDARDS

- A. ASTM – AMERICAN SOCIETY FOR TESTING AND MATERIALS.
- B. Standard specifications (as specified in the general provisions)

## PART 2 – PRODUCTS

- A. Provide structural fill as required to meet proposed subgrade elevations in accordance with grading plan, civil engineering specifications and testing agency recommendations.
- B. Provide the specified depth of compacted aggregate base material if required.
- C. Suitable materials may be obtained from onsite excavations, may be processed onsite materials, or may be imported provided these materials meet all the requirements in the contract documents. If imported materials are required to meet the requirements of this section or to meet the quantity requirements of the project, the contractor shall provide the imported fill materials and the required conformance reports of test results at no additional expense to the owner, unless a unit price item is included for imported materials (including the appropriate required testing reports) in the bidding schedule.

## PART 3 - EXECUTION

- A. Establish and maintain required lines and grade elevations. Designate and identify datum elevation and project engineering reference points.
- B. Before starting grading and excavation, establish the location and extent of underground utilities in the work area. Exercise care to protect existing utilities during earthwork operations. Perform excavation work near utilities by hand and provide necessary shoring, sheeting, and supports as the work progresses. Notify respective utility companies of damage caused to active utilities immediately.
- C. Proof-roll exposed subgrades with a loaded tri-axle dump truck or similar piece of rubber-tired construction equipment to assist in the evaluation of the subgrades across the site. If unstable areas are detected, an initial attempt should be made to aerate (12 inches min.) And densify the subgrade by re-compaction where natural moisture contents are at appropriate levels. If this procedure is ineffective, the disturbed soils should be undercut and replaced with clean fill and/or stabilizing materials. Compact to 95% of the maximum dry density in accordance with ASTM d698 standard proctor method. Fill and consolidate depressed areas. A firm, non-yielding subgrade should be established prior to proceeding with fill placement.
- D. Soil compaction shall be achieved by means of pneumatic tire rollers, hoe packs, ride-on drum roller or other mechanical tampers (plate, rammer, or walk behind roller).
- E. Bring up fill using stockpiled material and/or approved material with low plasticity. The fill should be placed in lifts thin enough to attain the specified compaction level throughout the entire lift thickness. Prior to compaction, moisture condition as needed. Compact each lift to at least 95 percent of ASTM d698.
- F. The excavation contractor shall remove all swellable soil as directed by the soils engineer.
- G. Excavation and compaction of fill shall extend to 5 feet beyond skate park footprint.
- H. Any portion of the backfill operation that does not meet the minimum compaction requirements of this section shall be removed, re-compacted, and re-tested at the cost of the contractor until passing tests are obtained.
- I. Proceed with sub-base if required only after nonconforming conditions have been corrected and subgrade has been inspected. A firm, non-yielding subgrade should be established prior to base course placement.
- J. Provide the specified depth of compacted aggregate base material if required. Compact aggregate base to 95% of the maximum dry density in accordance with ASTM d698 standard proctor method if required.
- K. Proceed with concrete only after nonconforming conditions have been corrected, subgrade has been inspected, and formwork and field mock-ups have been reviewed.
- L. Upon completion of earthwork operation, clean areas within contract limits, remove tools and equipment.

- M. Remove and dispose of properly off site all rocks and other debris from grading operations at approved recycling centers and/or licensed landfill, in accordance with local codes and ordinances.

END OF SECTION

**SECTION 03 20 00 – CONCRETE REINFORCING FOR SKATEPARKS****PART 1 - GENERAL**

## 1.1 SUMMARY

- A. All reinforcement to follow drawings, unless otherwise approved by the engineer/architect.

## 1.2 REFERENCE STANDARDS

- A. All reinforcing steel shall conform to ASTM a-615 grade 60.
- B. For reinforcing that is to be welded, conform to ASTM a706 grade 60.
- C. Use ASTM a-108 grade 60 for all welded anchors.
- D. Comply with CRSI'S manual of standard practice for fabricating reinforcement and with recommendations in CRSI'S "placing reinforcing bars for placing and supporting reinforcement.
- E. Latest ACI code and detailing manual apply.

## 1.3 RELATED SECTIONS:

- A. SECTION 03 10 00 - CONCRETE FORMING FOR SKATEPARKS
- B. SECTION 03 30 00 - CAST-IN-PLACE CONCRETE FOR SKATEPARKS
- C. SECTION 03 39 00 - CONCRETE CURING FOR SKATE PARKS

**PART 2 – PRODUCTS**

- A. Joint dowel bars: plain steel dowels, ASTM a 615/a 615m, grade 60. Cut bars true to length with ends square and free of burrs.
- B. Slip dowels are acceptable.
- C. Bar supports: bolsters, chairs, spacers and other devices for spacing, supporting, and fastening reinforcements bars, and dowels in place. Manufacture bar supports according to CRSI'S "manual of standard practice" from steel wire, plastic, or precast concrete or fiber-reinforced concrete of greater compressive strength than concrete.

**PART 3 - EXECUTION**

- A. Clean reinforcement of loose rust and mill scale, earth, ice, or other bond-reducing materials. Arrange, space, and securely tie bars and bar supports to hold reinforcement in position during concrete placement. Maintain minimum cover to reinforcement.
- B. All reinforcing bars to be deformed. Latest ACI code and detailing manual apply. Clear concrete coverages to any reinforcing including ties are as follows:
  - i. 2" formed concrete exposed to earth or weather.
  - ii. 1" slabs and joists not exposed to weather.
  - iii. 1-1/2" all other.
- C. Smaller clearances permissible for precast or pre-stressed.
- D. Tension lap splices in concrete: unless noted otherwise, provide the following:
  - i. #3, 22"; #4, 29"; #5, 36". Multiply by 1.3 for top bars.
- E. Minimum clear cover for spliced reinforcing is greater than one bar diameter, and minimum clear spacing is greater than two bar diameters. Splice bottom bar over supports and top bar at mid-span only. Where bars are shown spliced, they may run continuous at contractor's option.
- F. Place rebar per CRSI manual. Rebar spacings given are maximum on center whether stated as "o.c." or not, and all rebar is continuous whether stated as "cont." or not. Provide bent corner rebar to match and lap with horizontal rebar at corners and intersection of walls, beams, bond beams and footings per ACI manual. Dowel all vertical rebar to foundations. Securely tie all rebar, including dowels, in location before placing concrete or grout.

END OF SECTION

**SECTION 03 30 00 – CAST-IN-PLACE CONCRETE FOR SKATEPARKS****PART 1 - GENERAL**

## 1.1 SUMMARY

- A. Place all concrete to follow skatepark drawings, unless otherwise approved by the engineer/architect.

## 1.2 REFERENCE STANDARDS

- A. All concrete shall meet all the requirements of ACI 301 with type i/ii cement.
- B. All slab construction shall conform to ACI 302.1.

## 1.3 RELATED SECTIONS:

- A. SECTION 03 10 00 - CONCRETE FORMING FOR SKATEPARKS
- B. SECTION 03 20 00 - CONCRETE REINFORCING FOR SKATEPARKS

## 1.4 QUALITY CONTROL

- A. Concrete cylinders shall be taken and tested per the ACI code, when required by the project.

**PART 2 – PRODUCTS**

- A. All concrete shall meet all the requirements of ACI 301 with type i/ii cement. Minimum 28 day strength 4,000 psi, except as follows:
  - i. Small to medium aggregate (3/4" max.)
  - ii. Mix designs containing fly ash: the amount of fly ash used shall not exceed 20% by weight of the combined weight of fly ash plus cement.
  - iii. Air entrainment not to exceed 3%.
  - iv. Water/cement ratio of .45 or less

**PART 3 - EXECUTION**

## 3.1 CONCRETE PLACEMENT

- A. Do not install concrete work over saturated, muddy, or frozen subgrade.
- B. Protect adjacent work and provide temporary barricades as required for protection of project work and public safety.
- C. All reinforcing, including dowels and anchor bolts, shall be securely tied in location before placing concrete or grout. Dowels will not be allowed to be "stabbed" in.
- D. If entire slab cannot be poured in one day, subcontractor must discuss pour options with the skate park designer.
- E. Conduits, pipes, and sleeves embedded in concrete shall conform to the requirements of ACI 6.3.
- F. Mechanically vibrate all concrete flatwork when placed, except that slabs on grade and slabs on deck need to be vibrated only around embedded items.
- G. Consolidate concrete by mechanical vibrating equipment supplemented by hand-spading, rodding or tamping. Use equipment and procedures to consolidate concrete according to recommendations in ACI 309r.
  - i. Consolidate concrete along face of forms and adjacent to transverse joints with an internal vibrator. Keep vibrator away from joint assemblies, reinforcement, or side forms. Use only square-faced shovels for hand-spreading and

- consolidation. Consolidate with care to prevent dislocating reinforcement, dowels, and joint devices
- H. Cold weather placement: comply with ACI 306.1 and as follows. Protect concrete work from physical damage or reduced strength that could be caused by frost, freezing actions, or low temperatures.
    - i. When air temperature has fallen to or is expected to fall below 40 deg f, uniformly heat water and aggregates before mixing to obtain a concrete mixture temperature of not less than 50 deg f at point of placement.
    - ii. Do not use frozen materials or materials containing ice or snow.
    - iii. Do not use calcium chloride, salt, or other materials containing antifreeze agents or chemical accelerators, unless otherwise specified and approved in mix designs.
  - I. Hot-weather placement: place concrete according to recommendation in ACI 305r and as follows when hot-weather conditions exist:
    - i. Cool ingredients before mixing to maintain concrete temperature at time of placement below 100 deg fahrenheit. Chilled mixing water or chopped ice may be used to control temperature, provided water equivalent of ice is calculated to total amount of mixing water. Using liquid nitrogen to cool concrete is contractor's option.
    - ii. Fog-spray forms, reinforcement steel, and subgrade just before placing concrete. Keep subgrade moisture uniform without standing water, soft spots, or dry areas.
  - J. Finish: all exposed concrete surfaces are to receive hard steel trowel finish unless otherwise noted. Trowel until all visible pores are closed. Cease troweling before surface becomes glossy. Do not broom finish and do not trowel burn surface.
    - i. All edge tooling should be 1/8 inch radius unless otherwise specified.
  - K. Color: all concrete surfaces are to be natural gray color unless otherwise noted. Minor variations in appearance of colored concrete, which are similar to natural variations in color and appearance of uncolored concrete, are acceptable. Do not broom finish and do not trowel burn surface.

### 3.2 PAVEMENT TOLERANCES

- A. Contractor must achieve positive drainage for all surfaces within the skatepark area-- level to a tolerance of ¼ inch in 10 feet when tested with a 10 foot steel straightedge placed on the surface. Standing water will not be allowed. (refer to civil grading plan)

### 3.3 REPAIRS AND PROTECTION

- A. Remove and replace concrete pavement that is broken, damaged, or defective, or does not meet requirements in this section. The contractor shall fix all cracks and displacements larger than 1/16" up to the project completion.
- B. Protect concrete from damage. Exclude traffic from pavement for at least 14 days after placement. When construction traffic is permitted, maintain pavement as clean as possible by removing surface stains and spillage of materials as they occur.
- C. Maintain concrete pavement of free stains, discoloration, dirt, and other foreign material.

END OF SECTION



## SECTION 03 39 00 – CONCRETE CURING FOR SKATEPARKS

### PART 1 - GENERAL

- A. General: protect freshly placed concrete from premature drying and excessive cold or hot temperatures. Comply with ACI 306.1 for cold-weather protection and follow recommendations in ACI 305r for hot-weather protection during curing.

### PART 2 – PRODUCTS

#### 2.1 CURING MATERIALS

- A. Absorptive cover: AASHTO m 182, class 2, burlap cloth made from jute or KENAF, weighing approximately 9 oz./sq. Yd. Dry.
- B. Moisture-retaining cover: ASTM c 171, polyethylene film or white burlap-polyethylene sheet (bur lene).
- C. Water: potable.
- D. Curing compound: ASTM c-309, clear, odorless, water-based, no volatile organic compound emitting, non-staining, membrane-forming, compatible with subsequent concrete treatments. Acceptable product: atlas quantum-cure, or approved equal.
- E. Evaporation retardant: waterborne, monomolecular film forming, manufactured for application to fresh concrete, such as Eucobar evaporation retardant by the Euclid chemical company. Apply evaporation retardant to concrete surfaces if hot, dry, or windy conditions cause moisture loss before and during finishing operations. Apply to exposed surface of concrete according to manufacturers written instructions as necessary.

### PART 3 - EXECUTION

- A. Protect concrete surfaces against rapid drying. Keep moist for necessary amount of time to reach concrete strength and inhibit moisture loss after placing.
- B. Begin curing after finishing concrete, but not before free water has disappeared from concrete surface.
- C. **Curing methods:** cure concrete by curing compound, moisture curing, moisture-retaining-cover curing, or a combination of these as follows:
- i. Curing compound: meet requirements of manufacturer's current printed application instructions and coverage rate chart. For horizontal applications, immediately apply after all surface water has disappeared and the concrete surface is hard enough to walk on. For vertical applications, apply immediately after removing the concrete forms. Apply in a uniform and continuous manner. Avoid over-application or puddling of curing compound. Protect surface from water, adjacent shotcrete work, and debris.
  - ii. Moisture curing: keep surfaces continuously moist for not less than seven days with the following materials:
    - Water.
    - Continuous water-fog spray.
    - Absorptive cover, water saturated, and kept continuously wet. Cover concrete surfaces and edges, overlap seams min. 6" between adjacent absorptive covers.
  - iii. Moisture-retaining-cover curing: cover concrete surfaces with moisture-retaining cover for curing concrete, placed in widest practicable width, with sides and ends lapped at least 6 inches.
- D. **CRACKING:**
- i. Cracking from inadequate curing is not allowed. Saw cut joints and construction joints may be shown in the construction drawings for diagrammatic purposes only. The contractor may, with approval of the skatepark designer, recommend and detail other joints required to prevent cracking.
  - ii. The contractor shall fix all cracks and displacements larger than 1/16" (1.59mm) up to the project completion.

END OF SECTION

**SECTION 03 40 00 – PRECAST CONCRETE FOR SKATEPARKS****PRECAST CONCRETE SKATE ELEMENTS**

NOTE: PRECAST CONCRETE SKATE ELEMENTS TO BE SPOHNCRETE  
 PROVIDED BY SPOHN RANCH SKATEPARKS, INC.  
 6824 SOUTH CENTINELA AVENUE  
 LOS ANGELES, CALIFORNIA 90230  
 PHONE: 626.330.5803

**PART 1 - GENERAL****1.1 SPECIALTY SKATE PARK CONSTRUCTION**

- A. All work contained in this section is specialty skate park construction. Manufacturers and installers must meet the minimum experience requirements contained in the quality assurance section.

**1.2 GENERAL CONDITIONS**

- A. Requirements of the contract documents, including but not limited to, the general, special, and technical provisions, apply to work in this section as if restated completely herein.

**1.3 SCOPE OF WORK**

- A. Furnish materials, labor, transportation, services, and equipment necessary to install all precast concrete skate elements related to the skatepark as indicated on the drawings complete as shown and as specified herein.

**1.4 REFERENCES**

- A. Comply with the applicable reference specifications as specified in the general provisions and in accordance with applicable laws, codes and regulations required by owner. Comply with the current provisions of the following codes and standards:
- B. Annual book of ASTM standards, ASTM c 33 - standard specification for concrete aggregates, vol. 04.02, American society for testing and materials, Conshohocken, Pennsylvania 1996.

**1.5 QUALITY ASSURANCE**

- A. Regulatory requirements: comply with applicable laws, codes, and regulations required by authorities having jurisdiction over work.
- B. Owner expectation: the supply and install of precast concrete skate elements is specialized and requires highly qualified firms with specific experience and know-how in the manufacturing and installation of precast concrete skate elements.
- C. Required manufacturer experience:
  - i. Manufacturer of all precast concrete skate elements must maintain the capacity and facilities to produce the quantity and quality of goods specified without any delay to the progress of the work. A "qualifying facility" must have been in operation and producing precast concrete skate elements at that same location for five (5) years.
  - ii. Manufacturer must have completed ten (10) public skatepark projects.

D. Required installer experience:

- i. The precast concrete skate element installer to perform the installation work shall be factory trained / certified and have a minimum of five (5) years experience installing precast concrete skate elements as specified for this project. Precast concrete skate element installer must have completed ten (10) public skatepark projects.

## 1.6 SITE CONDITIONS

- A. Coordinate schedules of concrete placement to allow adequate time for installation of other related work.
- B. Coordinate earthwork and soils report requirements with placement requirements.
- C. Coordinate with form-work and finishes sections to provide finish floor levelness and flatness as specified herein. Slope to drains at grades and percent slope shown on contract documents.
- D. Ensure that irrigation sleeves, electrical conduit, drainage lines and other utility elements are accommodated and as-built located prior to placing concrete.

## 1.7 WARRANTY

- A. General description: in addition to manufacturer's warranties, warrant work for a period of one year from the date of final completion against defects in materials and workmanship.
- B. Additional items covered: warranty shall also cover repair of damage to other materials and workmanship resulting from defects in materials and workmanship.
- C. Exceptions: contractor shall not be held responsible for failures due to ordinary wear, neglect by owner, vandalism, or other causes beyond the contractor's control.
- D. Manufacturer's warranty: at a minimum, the warranty must provide 5 years of warranty coverage.

## 1.8 PRECAST CONCRETE SKATE ELEMENTS (GENERAL REQUIREMENTS)

- A. All numbered precast concrete skate element in the bid (as shown in the drawings) must be shipped and arrive on-site as fully integrated or "monolithic" pieces requiring no further assembly. Contractor must submit proof that the applicable manufacturing processes will produce elements that meet this specification.
- B. All skate elements shall be manufactured from high quality, steam cured, precast concrete.
- C. Finished precast concrete shall be free from honeycomb, cracks, defects in workmanship, and be of the highest quality.
- D. Poured-on-site elements or elements formed using shotcrete will not be acceptable for elements specified as precast.
- E. Precast concrete skate elements shall be reinforced with steel rebar, synthetic fiber, welded wire mesh, and meet the specifications listed below.
- F. All coping and edge protection shall be galvanized steel.
- G. All precast concrete skate elements must be self-retaining and have factory integrated sides and backs without the use of hardware or metal support legs.

- H. Precast concrete skate elements requiring site installation of retaining walls will not be acceptable.
- I. Any products that do not carry the thickness of the concrete throughout the entire piece and use a channel or waffle system with varying thicknesses will not be considered for this project. The structural reinforcement does not receive the proper coverage and the product is weak and not suited for a public facility.
- J. Any system that requires hardware, metal support legs, or turnbuckles will not be accepted.

## PART 2 – PRODUCTS

### 2.1 PRECAST CONCRETE SKATE ELEMENTS MATERIAL SPECIFICATIONS

#### A. CONCRETE:

- i. Type i/ii Portland cement
- ii. Max. ¾" rock aggregate (foam pellets are not acceptable)
- iii. Mechanically vibrated up-side-down in precise concrete mold (self-settling concrete is not acceptable)
- iv. Precast indoors off-site at least two weeks prior to installation
- v. Cured in temperature- and humidity- controlled environment
- vi. Min. 4000 psi, max 7000 psi compressive strength @ 28 days (psi above 7500 is not acceptable)
- vii. Slump: 2-3"
- viii. Air entrainment: 3-5%

#### B. REINFORCEMENT:

- i. Reinforcing steel shall be new billet deformed bars and welded wire steel mesh and shall conform to ASTM standard a615 and a185 respectively. Minimum cover for all reinforcing shall be 1".
- ii. No. 4 rebar steel reinforcing @ 16" o.c. max. Grid steel reinforcing
- iii. ¼" welded wire mesh (WWM) steel reinforcing @ 6" o.c. grid
- iv. Synthetic macro fiber reinforcement meeting ASTM c1116

#### C. FINISH

- i. All precast concrete skate elements must transition to the slab without the use of transition plates
- ii. Riding surfaces hand-finished smooth after concrete sealer applied

#### D. JOINTS:

- i. Hand finished with cementitious grout or caulk as needed.

#### E. STEEL COMPONENTS:

- i. Coping: 2 3/8" schedule 40, ASTM a 53 steel pipe shall be anchored to concrete ramp at 12" on center with steel studs, fitted with welded end caps and then ground smooth. Vent adequately for galvanizing finish. ASTM a 123 hot-dip galvanizing to occur after all welding is complete. Where field welds are necessary, use a high zinc dust content paint for re-galvanizing welds in galvanized steel.

- ii. Angle edge protection: 1.5" x 2" x 3/16" thick, ASTM a36 steel angle shall be anchored at 12" on center. ASTM a123 hot-dip galvanizing finish to occur after all welding is complete. Where field welds are necessary, use a high zinc dust content paint for re-galvanizing welds in galvanized steel. The amount of edge protection can be customized to specifications.
- iii. Channel edge protection: 2" x 4" x 2.5" x 1/8" thick ASTM a36 folded steel plate shall be anchored into the concrete ramp at 12" on center. ASTM a123 hot-dip galvanizing finish to occur after all welding is complete. Where field welds are necessary, use a high zinc dust content paint for re-galvanizing welds in galvanized steel. The amount of edge protection can be customized to specifications
- iv. Grind rail-rectangular: 3" x 2" x 1/8" thick ASTM a500 steel tube. All grind rails shall be fitted with welded end caps and then ground smooth. Vertical supports are 2" x 2" x 1/8" or 2" x 3" x 1/8" ASTM a500 steel tubing welded to the horizontal rail. All welds to be all around. Grind welds smooth before galvanizing finish. Vent adequately for galvanizing. ASTM a123 hot-dip galvanizing to occur after all welding is complete. These are cast or surface mounted into the concrete foundation during installation as specified in the construction drawings.
- v. Grind rail-round: 2 3/8" schedule 40, ASTM a 53 steel pipe. All grind rails shall be fitted with welded end caps and then ground smooth. Vertical supports are 2 3/8" schedule 40 ASTM a 53 steel pipe welded to the horizontal rail. All welds to be all around. Grind welds smooth before galvanizing finish. Vent adequately for galvanizing. ASTM a123 hot-dip galvanizing to occur after all welding is complete. These are cast or surface mounted into the concrete foundation during installation as specified in the construction drawings.
- vi. Guard rails (when applicable): 2" diameter ASTM a500 steel tube w/ ASTM a123 hot-dip galvanized corrosion resistant finish. Guard rail frame formed and rounded at corners with 1" diameter tube vertical pickets evenly spaced at no more than 4" on center. All guard rails shall be cast or surface mounted into the concrete foundation. Guard rails shall be a minimum of 42" high and shall prevent passage of a sphere equal to or greater than 4" outside diameter. Safety rails are constructed in a manner that does not allow a skateboard underneath and through the opening between the bottom of the rail and the resting deck.

## 2.2 INSPECTION

- A. Inspect subgrade, forms, reinforcing steel, pipes, conduits, sleeves, hangers, anchors, inserts, and other work required to be built into concrete and report any discrepancies. Notify owner's representative at least 5 working days in advance of scheduled placement.
- B. Correct unsatisfactory work prior to placing concrete.
- C. Remove rubbish from formwork immediately prior to placing concrete.

## 2.3 REPAIRS AND PROTECTION

- A. Remove and replace precast concrete skate elements that are broken, damaged, defective, or do not meet the requirements of this section or conformance with ASTM f 2480 - standard guide for in-ground skate parks.
- B. Protect precast concrete skate elements from damage until final payment. Exclude traffic from precast concrete skate elements for at least 28 days after placement.

## 2.4 OTHER

- A. Concrete manufacturing and testing practices are undertaken in accordance with the national precast concrete association (NPCA), Canadian Standards Association, and American Standards & Testing Methods (ASTM) standards.
- B. Safety and performance guidelines: comply with all safety and performance requirements and all applicable references as specified in the ASTM f2480 standard guide for in-ground skate parks.

## 2.5 SUBSTITUTIONS

1. Basis of design: Spohncrete by Spohn Ranch Skateparks. Contractors seeking to use precast concrete skate elements other than Spohncrete by Spohn Ranch Skateparks must obtain the engineer/architect's pre-approval. Any product that is not pre-approved will not be considered.
2. The engineer/architect must receive, at least ten (10) calendar-days prior to bid opening, all documents and other submittals required to establish equality of a proposed precast concrete product. Any submissions for approval that do not allow for a 10 day review period will not be accepted.
3. The engineer/architect shall approve, disapprove, or require additional information for each request. Engineer/architect shall have absolute discretion to determine whether any precast concrete product meets the specifications. Any approved precast concrete products shall be identified in an addendum.
4. Requirements for precast concrete skate element pre-bid submittals:
  - a. Must include installation photos from a minimum of ten (10) listed project references demonstrating that the proposed product is a monolithic concrete-system that does not require site-installed walls, metal support legs or any kind of hardware.
  - b. Must include shop drawings and/or construction details that answer the following questions:
    - i. Is the product cast with integral galvanized steel edging/coping?
    - ii. Is the product cast via an "upside down" casting method with mechanical vibration for optimal consolidation of concrete against steel? (ie. Edging/coping not field-installed)
    - iii. At 28 days, is the product's compressive strength a minimum of 4,000 psi?
    - iv. Is the product cast and cured indoors in a temperature and humidity-controlled environment for at least two weeks prior to installation?
    - v. Is the product reinforced with steel rebar, synthetic macro fiber and welded wire mesh?
  - c. Product warranty. At a minimum, the warranty must provide 5 years of warranty coverage.
5. Precast concrete skate element pre-bid submittals shall include the cost of all changes in the structure, mechanical, electrical work, and other appurtenances, including engineering costs from redesign, for the accommodation of such equipment at the expense of the contractor.
6. The pre-bid submittals shall list any and all deviations from items specified, and the advantages to be derived if the deviation is approved. If no deviations are noted, it will be assumed that no such deviations exist, and the final submittals will allow no deviations.

## PART 3 - EXECUTION

### 3.1 DELIVERY, STORAGE, AND HANDLING

- A. Coordinate with work of cast-in-place concrete section.
- B. Precast concrete skate elements are to be stored at manufacturer's facility, above ground on skids or other supports, until site is ready for their installation.
- C. Precast concrete skate elements can be placed after a 7 day minimum curing time of the precast footings.
- D. Suitable skate park site access is required for delivery and placement of precast concrete skate elements. Access must allow tractor-trailer(s) and 60-ton crane (typ.) to park directly adjacent to footings, without obstruction, for delivery and placement of elements.

### 3.2 INSTALLATION

- A. Precast concrete skate elements are to be installed in accordance with manufacturer's installation instructions and work is to be performed by factory certified/trained installers.
- B. All joints created by the placement of concrete adjacent to precast concrete skate elements is the responsibility of the party placing the abutting concrete.

END OF SECTION

## SECTION 07 92 00 – JOINT SEALANTS FOR SKATEPARKS

### PART 1 - GENERAL

#### 1.1 DESCRIPTION

- A. General: construct construction, isolation, and contraction joints and tool edgings true to line with faces perpendicular to surface plane of concrete. Construct transverse joints at right angles to centerline, unless otherwise indicated.

#### 1.2 RELATED SECTIONS:

SECTION 03 30 00 - CAST-IN-PLACE CONCRETE FOR SKATEPARKS

### PART 2 – PRODUCTS

- A. Expansion and isolation joint filler strips: expansion joint materials shall be flexible polyethylene closed cell foam or similar and supplied by concrete contractor. Deck-o-foam or equivalent.
- B. Expansion joint sealant: Sikaflex - 1a ns tg polyurethane elastomeric sealant, or approved equal. Color of caulk should resemble natural color of concrete (aluminum gray or limestone).
- C. Saw cut joint sealant: sikaflex-1c sl high performance, self-leveling, 1-part polyurethane sealant, or approved equal. Color of caulk should resemble natural color of concrete (aluminum gray or limestone)

### PART 3 - EXECUTION

#### 3.1 CONCRETE

- A. Expansion joints: form expansion joints of specified joint-filler strips where indicated
- i. Locate expansion joints as indicated on drawings.
  - ii. Extend joint fillers full width and depth of joint.
- B. Install dowel bars and support assemblies at joints where indicated. Lubricate or asphalt-coat one-half dowel length to prevent concrete bonding to one side of joint.
- C. Control joints: form weakened-plane joints, sectioning concrete into areas as indicated. Construct control joints for a depth as indicated in the drawings (generally 1/3 of the pavement thickness), as follows:
- i. Sawed joints: form control joints with power saws equipped with shatterproof abrasive or diamond-rimmed blades. Cut 1/8 inch wide joints into concrete when cutting action will not tear, abrade, or otherwise damage surface an before developing random contraction cracks. Early saw cuts are approximately 1 inch deep, regardless of pavement thickness. Refer to control joint guide drawing of plan set if applicable.
  - ii. If skatepark project design utilizes poured steps, control joints must be cut 3 - 4 feet from the edge of the top step.
- D. All joints created by the placement of concrete adjacent to precast concrete skate elements is the responsibility of the party placing the abutting concrete.



- E. Post cure detail work (as needed): grind smooth any inconsistencies in the finish or high spots between pours.

END OF SECTION

**SECTION 16000 - ELECTRICAL****1. PART 1 GENERAL REQUIREMENTS****1.1 SCOPE OF WORK**

- A. The work covered by this section consists of furnishing and installing all I, materials, equipment, fixtures and performing all labor and operations for complete and operable systems.
- B. Provide all new materials, unless noted otherwise, of the best quality, and in perfect condition, and materials of the same make and quality throughout the work and as hereinafter specified. Comply with the requirements of ASTM, NEMA, U.L., and NBFM for materials and equipment.
- C. The intent of these specifications is to establish a standard of quality of materials installed. Include materials as specified without exception in the Base Bid. Submit for approval any proposed substitution, complete descriptive, technical, and cost comparison data and test reports. Do not furnish or install any substitute items without written approval at the time of contract signing. Reimburse the Owner for any additional engineering charges and for any changes in the work of other trades resulting from substitutions. List proposed substitutions on the Bid Form, stating the reasons for substitution. When requested by the Architect or Electrical Engineer, samples, electrically wired at 120V with plug, or system demonstrations of both specified and proposed items will be submitted for inspection at the Electrical Engineer's office and at a time convenient to all concerned parties.
- D. Where a substitution alters the design or space requirements indicated on the plans, Contractor is responsible for all additional cost for Engineering to revise plans.
- E. Verifying Drawings and Job Conditions:
  - 1. Examine all drawings and specifications in a manner to be fully familiar of all work required.
  - 2. Visit the site and verify existing conditions. Where existing conditions differ from drawings, make adjustments and allowances for all necessary equipment to complete all parts of the drawings and specifications.
- F. Shop Drawings:
  - 1. Submit drawings in six sets accompanied by letter of transmittal listing the number and dates of the drawings submitted.
  - 2. Mark the drawings submitted with the name of the project, numbered consecutively, and bearing approval as evidence that the drawings have been checked. Any drawings submitted without this approval will be returned for resubmission.
  - 3. Submit Shop drawings on, but not limited to, the following:
    - a. Time Switch
    - b. Lighting Fixtures
    - c. Product List

G. Drawings of Record:

Provide and keep up-to-date, a complete record set of blue line prints. Show every change from the original drawings. Keep this set of prints on the job site, and use only as a record set. Do not make changes in the layout without definite instruction in each case. Obtain a set of Contract Drawings from Architect and incorporate all changes as noted on the record set of prints. Deliver this set to the Architect upon completion and acceptance of work.

H. Accuracy of Plans and Specifications:

Plans and/or specifications showing deviation from standard practice methods or from compliance with codes, and/or any omissions, does not relieve the responsibility of furnishing, making or installing all items required by code and/or intended for the function of the system.

I. Permits, Fees and Insurance:

Obtain and pay for all insurance, permits, etc. necessary for this Contract.

J. Codes and Regulations:

All work performed under this Section of the Specifications complies with the rules and regulations of the Division of Industrial Safety, State of California, as set forth in the latest edition of the Electrical Safety Orders, the National Electrical Code, NFPA, and all rules and regulations of local codes having jurisdiction, including the presently adopted edition Title 21 and 24 California Administrative Code.

K. Testing and Adjustment:

Test all circuits, outlets, switches, lights, motors, circuit breakers and any other electrical equipment, upon completion of all electrical work.

L. Guarantees of Materials and Workmanship:

Furnish and install all materials under this Contract, new and free from all defects, and guaranteed for a period of two years from the date of acceptance of the work. Should any trouble develop during this period due to defective material or faulty workmanship, furnish all necessary labor and materials to correct the trouble without additional cost to the Contract. Correct any defective material or inferior workmanship noticed at the time of installation immediately, to the satisfaction of the Architect.

M. Removal of Rubbish:

Remove rubbish, excess materials, tools or equipment related to this portion of the work, frequently during construction and upon completion of the work.

N. Drawings and Specifications:

1. The electrical drawings are considered as part of these specifications, and any work or materials shown on the drawings and not mentioned in the specifications, or vice versa, shall be as if specifically mentioned in both.
2. The data herein specified and shown on the drawings is as exact as could be

prepared, but their extreme accuracy is not guaranteed. The drawings and specifications are for assistance and guidance. The installation is essentially as shown and specified. The exact location of the equipment, material, apparatus and devices as well as the distances and levels, are more or less governed by the physical conditions and arrangements of the building. Accept this Contract with this understanding.

3. Make minor changes, when ordered by the Architect, accommodating the installation of the work with other sections of the Contract without additional cost to the Contract.

O. Safety Conditions:

It is the Contractor's responsibility to prevent any damages to personnel and/or property resulting from contact with new or existing energized circuits, switches, circuit breakers, or other electrical apparatus. All electrical work to be constructed with electrical systems de-energized in the area of work.

P. Final Inspection and Acceptance:

After all requirements of the specifications and drawings have been fully completed, a representative of the Owner will inspect the work. Provide competent personnel to demonstrate the operation of any item or system involved to the complete satisfaction of each representative.

## 2. PART 2. PRODUCTS

### 2.1 CIRCUIT BREAKERS:

Provide circuit breakers with inverse time characteristic thermal and magnetic tripping elements, with an interrupting capacity of not less than 10,000 amperes, UL labeled, NEMA rated, molded case type. Use common trip single handle multi-pole breakers. Handle extensions are not permitted. All circuit breakers will have covers sealed on non-interchangeable trip breakers and trip unit covers sealed in interchangeable trip breakers to prevent tampering. Be sure the circuit breaker current rating markings clearly visible after breaker is installed. One manufacturer for all circuit breakers for a given panel. Provide bolt-on circuit breakers unless specifically noted on electrical drawings.

### 2.2 RELAYS:

Install control relays for automatic controls or for interlocking as indicated in the drawings. Provide relays with the number and type of poles and with operating coils as indicated. Equip relays with contacts rated not less than 15 amperes for continuous inductive load, unless otherwise shown or specified. Rate operating coils for continuous duty at the operating voltage shown on the drawings.

### 2.3 LIGHTING FIXTURES:

Furnish, install and connect lighting fixtures of type designed on the plans.

- A. Verify all fixture locations with Landscape Architectural drawings prior to rough in.
- B. Where there is conflict in fixture quantities on any of the plans the greatest amount will prevail. The description of the lighting fixture supersedes the catalog number and is to be furnished and installed with type to fit description.

## 2.4 CONDUIT AND FITTINGS:

- A. Rigid Conduit (RGS): Hot dipped galvanized or sherardized steel. Republic Steel Co. or approved equal. Intermediate metal conduit may be used, where CEC allows, in lieu of RGS.
- B. Electrical metallic tubing (EMT): Welded, electro-galvanized thin wall steel tubing. All couplings are gland compression type.
- C. Non-metallic conduit (PVC): Polyvinyl chloride Schedule 40 or 80. Install a copper ground wire, sized per National Electrical Code, in all non-metallic conduit power raceways. Use PVC in underground installations only.
- D. Liquidtight Flexible Metal Electrical Conduit: Hot-dipped galvanized steel with exterior, molded polyvinyl jacket. Use for all final connections to all vibrating equipment, transformers and the like. 18" maximum. Provide a code sized ground wire.
- E. Flexible metallic steel tubing: Liquid tight without a nonmetallic jacket. Use as allowed by code and where permitted by this Specification, section 3.06.C. Provide a code sized ground conductor.
- F. Condulet Type Fittings: As manufactured by Crouse Hinds Company, Appleton Electric Company or Pyle National or approved equal, smooth inside and out, taper threaded with integral bushings.

## 2.5 CONDUCTORS:

- A. Provide copper conductors, 600 volt A.C. unless noted otherwise. Aluminum conductors are not permitted.
- B. Use THWN conductors for underground and damp locations, THHN for dry areas.
- C. Deliver conductors to the site in unbroken packages, marked with the manufacturer's name, date of manufacture, voltage and classification letters. Use only wire recently manufactured (10 months or less).
- D. Provide signal service and low voltage control conductors as specified or noted on the drawings.
- E. No conductor supplying 120 volts or more will be smaller than No. 12 AWG unless otherwise noted on the drawings.
- F. Fixture wire to comply with latest requirements of the National Board of Fire Underwriters. The carrying capacity of the wire as per the latest requirements of the National Electrical Code. No fixture wire may be smaller than #18 gauge. Protect wiring with tape or tubing at all points where abrasion is likely to occur.
- G. Install all conductors of each electrical system in an approved raceway. Factory assemblies, non-metallic/pliable/corrugated raceways, type UF cable or multi-conductor assemblies are not approved.
- H. Use solid conductor, size #10 AWG and smaller, stranded for #8 AWG and larger.

## 2.6 JUNCTION AND PULL BOXES:

Above grade level, provide galvanized junction and pull boxes with removable covers, secured with machine screws. The sizes of all boxes determined by the number and size of conductors entering the box, and by the sizes of conduit terminating in the box. All boxes conform to the applicable Electrical Safety Orders, State of California. Pullboxes flush with grade shall be concrete, with bolt down concrete or steel covers, per plans, with engraved or beadweld identification.

### 3. PART 3. EXECUTION

- 3.1 If construction of building reveals that any part of the Electrical Work would not be readily accessible if installed according to drawings, notify the Architect before proceeding with such installation.
- 3.2 All concrete work such as pull boxes, raised pads, conduit envelopes and other areas where affecting Electrical Work are the responsibility of the Electrical Contractor.
- 3.3 Coordinate layout and installation of electrical work with the overall construction schedule and work schedules of various trades to prevent delay in completion of the project.
- A. Verify dimensions and information regarding accurate location of equipment, structural limitations, and finish with other affected sections.
- B. Job Conditions:  
  
The drawings do not always show offsets, bends, special fittings or junctions or pull boxes necessary to meet job conditions. Provide the items as required at no cost to the Owner.
- C. Weatherproof Equipment:  
  
Use weather resistant electrical devices or equipment located in damp, semi-exposed areas. Comply with NEMA Type 3R requirements for enclosures.
- D. Where devices are shown diagrammatically in the same location, neatly group them together in a reasonable manner. Provide one-piece plate where such is manufactured.
- 3.4 Equipment requiring electrical under other sections is part of the Contract. Work includes all necessary connections.
- 3.5 EXCAVATION AND BACKFILLING:  
  
Excavate and backfill in accordance with section in these documents covering that work.
- 3.6 CONDUIT:
- A. Install all conduit concealed, except where specifically indicated as exposed. Use rigid galvanized steel or I.M.C. for all exposed conduit. Paint with two coats to match adjacent surroundings, if viewed by the public.
- B. Use galvanized rigid steel on all conduit installed in concrete and masonry walls, 3/4 inch trade size minimum, unless otherwise specified and/or noted on the plans. Verify conduit runs in concrete slab, prior to placement. Otherwise, do not run conduits in slabs.
- C. All conduit installed in the dry walls or dry ceilings of the building structures, shall be steel tube (EMT), except that in certain locations and for certain runs where it is impractical to

install EMT, and where permission to do so has been given by the Architect, galvanized flexible steel conduit may be used, with a code sized ground conductor.

- D. Run conduit so as not to interfere with or contact other piping, fixtures or equipment. Maintain 6" separation from water piping.
- E. Cut the ends of all conduit square and carefully ream out to full size, and shoulder in fitting.
- F. No running threads will be permitted in locations exposed to the weather, in concrete or underground. Use special watertight union fittings in these locations.
- G. Use PVC Schedule 40 or 80 for all underground conduits. Install all underground conduit at a depth of not less than 24 inches below the final finish grade, unless under concrete slabs or otherwise noted and/or specified. Cap PVC conduit with minimum 3 inch concrete cap or provide metallic high voltage tape buried 12" above conduit, except under floor slab or under concrete walk, in which case, install 6" below bottom of slab. Use IMC for all horizontal and vertical sweeps or risers with factory applied PVC coating. Verify with serving utilities for service conduits, bends, depth below grade, backfill, etc. for specific types. Schedule 80 PVC sweeps are permitted for conduits 4" diameter and greater.
- H. Cut and patch all pavements, curbs, sidewalks and gutters, whenever necessary for laying conduit, or whenever damaged by the operations of this trade. Replace materials with quality and finish equal to that removed or damaged.
- I. Where conduit extends through roof to equipment on roof areas, provide weatherproofing as specified in the appropriate section of these Specifications.
- J. Support all conduit in intervals not less than 10'-0" and within 36 inches from any outlet and at each side of bends and elbows. Use galvanized, concealed conduit supports, heavy stamped, one hole malleable conduit clamps secured with nails. On exposed conduit supports, use two hole clamps with screws, or galvanized steel framed channels secured by screws may be used for conduit supports. Perforated iron for supporting conduit is not permitted.
- K. Use rigid galvanized steel or I.M.C., threaded, for exposed conduit runs. Install parallel or perpendicular to walls, structural members or intersection of vertical plane and ceilings. Avoid field made bends and offsets where possible. Do not install crushed or deformed raceways.
- L. Provide metal sleeves and install where conduit passes through masonry or concrete walls. Use No. 20 gauge galvanized steel sleeves, no more than 1/2 inch greater in diameter than the outside diameter of the conduit. Caulk conduit into sleeves with stone wool, Duseal or Oakum and weatherproof below grade. Where conduit passes through fire resistive walls, partitions, and floors, pack void spaces between conduits with U.S.G. Thermafiber or equal, as approved by the State Fire Marshal.
- M. Provide a heavy nylon cord pull rope in all empty conduits for future use. Leave in place for future use in all runs and tagged with plastic tag at terminating end indicating the location of the opposite end of the conduit.
- N. Use factory-manufactured ells, except where noted otherwise. Field bends are permitted for EMT conduit less than 1" diameter. Conduit radius for signal system is ten times the internal diameter of the conduit.
- O. Cap or seal all conduit ends until wires are pulled.

- P. Use watertight gland compression type connectors and couplings on fittings for thin wall metallic conduit. Screw type or crimp type are not permitted.
- Q. Wire all rotating electrical equipment with flexible, liquid-tight conduit with appropriate slack from disconnect switch to equipment.
- R. Install expansion coupling at all expansion joint locations, refer to Architectural. Drawings for locations.
- S. Use approved type-bending machines for PVC conduits. Use of blow torch is prohibited.
- T. For grouping, use conduit trapezes made up of suitable Unistrut or Kindorf hangers.
- U. Seal or cap all conduit for a watertight installation.
- V. Use approved conductor pulling machines for all underground conduits. Use of truck is prohibited.

### 3.7 INSTALLATION OF CONDUCTORS:

- A. Unless otherwise indicated or specified, do not install conductors of less than No. 12 AWG size. For control conductors protected by 15 ampere or lower overcurrent protection, No. 14 AWG conductors will be installed. Where approved by Code, remote control and signal circuits utilize No. 18 or No. 16 AWG sizes. Increase No. 12 to No. 10 AWG for 120 volt home runs exceeding 75 feet.
- B. Color code power wire and cable for feeders and branch circuits.
- C. Install all electrical conductors, including signal and communications circuits in an approved raceway.
- D. Neatly group conductors in panels, switchgear and terminal cabinets, etc., and form in a manner to fan into terminals with regular spacing. Lace formed groups of conductors with No. 12 waxed twine, or Panduit Co. Nylon Straps Numbers "SST-4-H" or "SST-2". Lace larger conductors with marlin and secure with cleats, or Panduit Co. Nylon Sta-Straps Numbers "SSC-4-H" and tie anchors ETA-1, TA-2 or TM-1-2-3.
- E. Install U.L. approved covered wire from all lighting fixture lamp sockets into outlet or junction box.

### 3.8 WIRING COLOR CODE

- A. 208Y/120 Volt System
  - Phase A - Black.
  - Phase A Switch Leg - Black with "S" tag.
  - Phase B - Red.
  - Phase B Switch Leg - Red with "S" tag.
  - Phase C - Blue.
  - Phase C - Switch Leg - Blue with "S" tag.
  - Travelers - Yellow.
  - Neutral - White.
  - Equipment Ground - Green.



- B. 480Y/277 Volt System
  - Phase A - Brown Phase A - Brown.
  - Phase A Switch Leg - Brown with "S" tag.
  - Phase B - Orange.
  - Phase B Switch Leg - Orange with "S" tag.
  - Phase C - Yellow.
  - Phase C Switch -Leg- Yellow with "S" tag.
  - Travelers - Yellow with "T" tag.
  - Neutral - Grey.
  - Equipment Ground - Green with Yellow stripe.
- C. Provide identification tags on each conductor entering panel, switch, junction box and pull box to identify conductor.

### 3.9 UNDERGROUND PULL BOXES:

- A. Set underground pull boxes at +3" above highest adjacent grade level.
- B. No splices in Fire Alarm or Signal System conductors are permitted.
- C. Size per NEC.
- D. Provide nameplate on all covers.

"ELEC"

### 3.10 CONDUCTOR JOINTS AND TAPING:

Make joints in conductors smaller than No. 6 AWG with solderless, tapeless, wing nut type pressure cable connector. Join conductors No. 6 AWG and larger together with approved type or pressure connector and tape to provide insulation not less than that of the conductor. Make connections to switch or bus bar with one-piece copper lugs for conductors No. 8 AWG or larger.

### 3.11 GROUNDING:

Provide grounding for entire electrical installation as required by the serving utility and codes mentioned in these specifications. Including:

- A. Conduit.
- B. Neutral or identified conductor of interior wiring system.
- C. Power and lighting panelboards.
- D. Non-current carrying metal parts or fixed equipment.
- E. Electrical panels in separate buildings.

END OF SECTION

# APPENDICES

## APPENDIX A LOCATION MAP

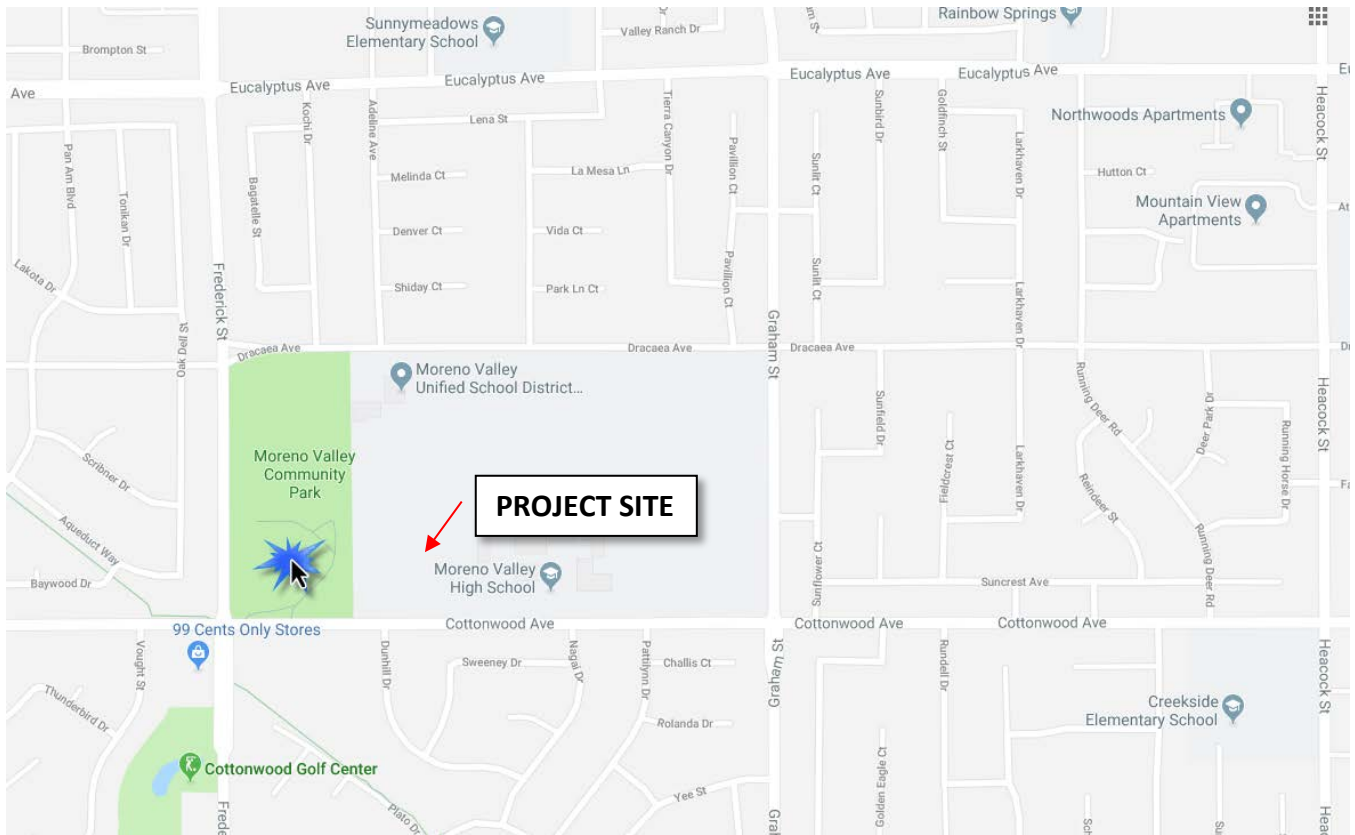

Attachment: SPECIAL PROVISIONS - MVCP SKATE PARK (3355) : APPROVE AND EXECUTE AGREEMENT WITH MICON CONSTRUCTION FOR

**APPENDIX**

**CITY STANDARD PLANS**

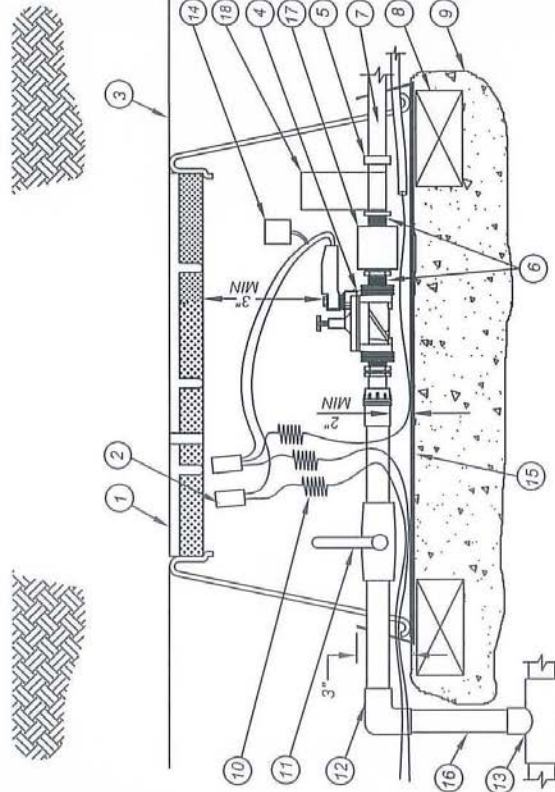



**LEGEND:**

- 1 SUPER JUMBO VALVE BOX WITH COVER PER SPECIFICATIONS
- 2 CONNECTORS PER SPECIFICATIONS.
- 3 1" ABOVE GRADE TOP IN TURF AREAS  
3" ABOVE GRADE IN SHRUB AREAS
- 4 RCY PER SPECIFICATIONS
- 5 SCH 80 PVC THREADED UNION (2)
- 6 PVC SCH 80 NIPPLE
- 7 LATERAL LINE ANGLE WITH 45 DEGREE ELLS TO SPECIFIED DEPTH
- 8 CONCRETE BRICK SUPPORT AT EACH CORNER
- 9 3/4" GRAVEL SUMP - MINIMUM 6"
- 10 WIRE EXPANSION LOOP (MIN 24" LENGTH)
- 11 FEBCO T585-70-66 BRONZE BALL VALVE
- 12 PVC SCH 80 90 DEGREE ELL
- 13 SCH 80 SST. MAINLINE SIZE (LEEMCO RESTRAINT TEE ON 4" AND LARGER PIPE)
- 14 CHRISTY TAG WITH VALVE AND STATION NUMBER
- 15 1/4" GALVANIZED MESH SCREEN
- 16 SCH 80 NIPPLE
- 17 PRESSURE REGULATOR PER SPECIFICATIONS
- 18 FILTER PER SPECIFICATIONS

**NOTES:**

- 1.) INSTALL CONTROL VALVES A MINIMUM OF 24" FROM STRUCTURES OR HARDSCAPE.
- 2.) INSTALL VALVES IN PLANT BEDS WHEREVER POSSIBLE NEXT TO SIDEWALKS.
- 3.) PLACE VALVE BOX AT RIGHT ANGLES TO STRUCTURES OR HARDSCAPE.
- 4.) PLACE AGGREGATE PRIOR TO INSTALLATION OF VALVE BOX.
- 5.) ATTACH VALVE IDENTIFICATION TAG WITH APPROPRIATE CONTROLLER AND VALVE NUMBER TO CONTROL WIRE.
- 6.) ONE VALVE PER BOX ALLOWED ONLY.

NOT TO SCALE

|   |   |  |                                     |
|---|---|--|-------------------------------------|
|  | RECOMMENDED:<br> 11/21/14<br>DIVISION MANAGER DATE                   | <b>CITY OF MORENO VALLEY</b><br>PARKS AND COMMUNITY SERVICES DEPARTMENT  | STANDARD PLAN<br><b>MVLI-553B-0</b> |
|   | APPROVED:<br> 1/29/14<br>PUBLIC WORKS DIRECTOR DATE<br>CITY ENGINEER | <b>REMOTE CONTROL VALVE DETAIL<br/>                 FOR DRIP SYSTEMS</b> |                                     |

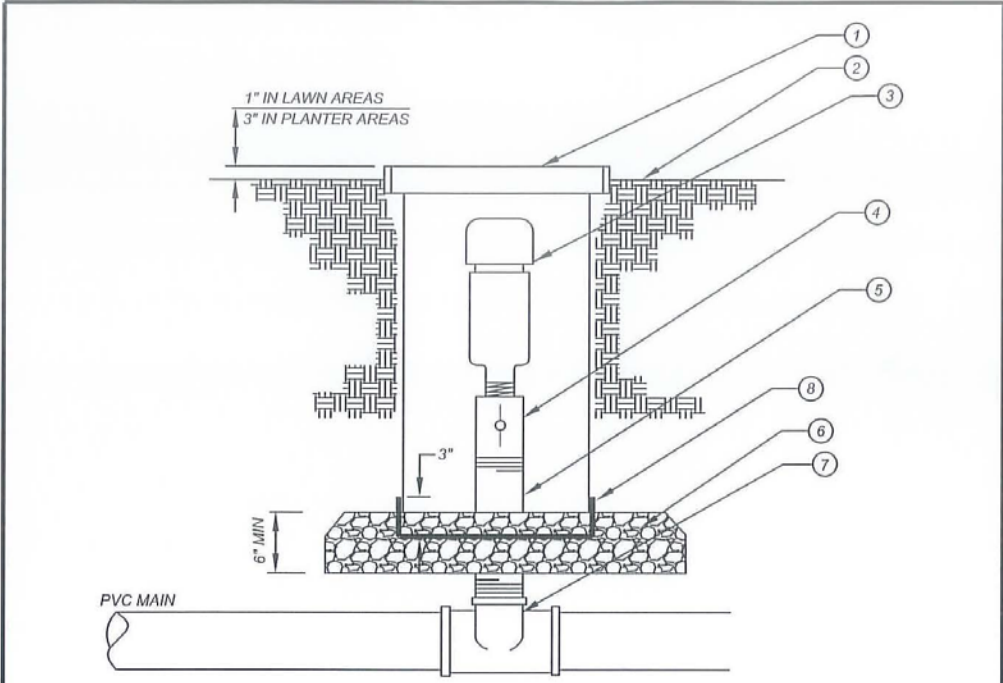

**LEGEND:**

- ① 10" ROUND VALVE BOX WITH LOCKING LID, "ARV" TO BE BRANDED ON LID. USE VALVE BOX EXTENSIONS AS NECESSARY TO REACH FINISH GRADE
- ② FINISH GRADE
- ③ 1" AIR/VACUUM RELIEF VALVE
- ④ 1" SCH 80 PVC BALL VALVE (FIPT X FIPT)
- ⑤ 1" SCH 80 PVC NIPPLE
- ⑥ 3/4" WASHED CRUSHED AGGREGATE BASE
- ⑦ SCH 80 PVC TEE (S x S x T) OR 90° ELL (S x T)
- ⑧ 1/4" GALVANIZED MESH WIRE

**NOTES:**

1) PLACE AGGREGATE PRIOR TO INSTALLATION OF BOX.

NOT TO SCALE

|   |  |   |  |
|---|--|---|--|
|  | RECOMMENDED:<br><i>FD</i> 1/21/14<br>DIVISION MANAGER DATE                               | <b>CITY OF MORENO VALLEY</b><br>PARKS AND COMMUNITY SERVICES DEPARTMENT | STANDARD PLAN  |
|   | APPROVED:<br><i>[Signature]</i> 1/29/14<br>PUBLIC WORKS DIRECTOR / DATE<br>CITY ENGINEER |   | <b>AIR VACUUM RELIEF VALVE</b><br><b>MVLI-555B-0</b><br>SHEET 2 OF 2 |

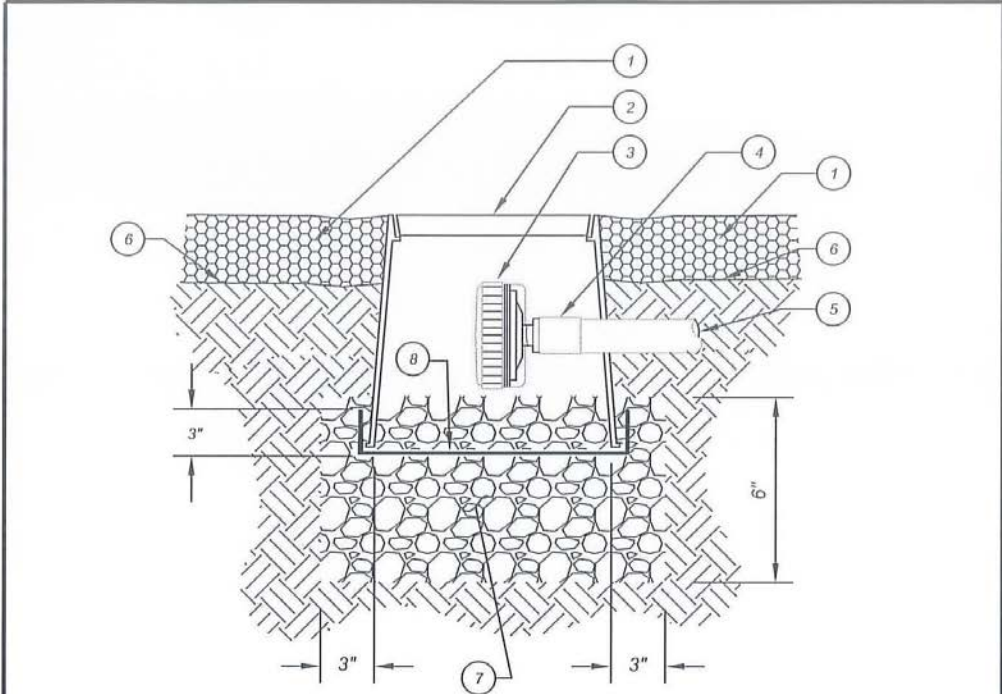

Attachment: SPECIAL PROVISIONS - MVCP SKATE PARK (3355) : APPROVE AND EXECUTE AGREEMENT WITH MICON CONSTRUCTION FOR



- 1 FINISH SURFACE OF MULCH (3" THICK)
- 2 10" ROUND VALVE BOX WITH BOLTS AND WASHER. SEE NOTE BELOW
- 3 AUTOMATIC FLUSH VALVE
- 4 1/2" PVC COUP (FIPT x FIPT) WITH 1/2" MPT ADAPTER
- 5 DRIPPERLINE MANIFOLD CONNECTION
- 6 FINISH GRADE OF SOIL SURFACE, 3" - 4" COVER OVER PIPE
- 7 3/4" GRAVEL SUMP
- 8 1/4" GALVANIZED WIRE MESH

**NOTE:**  
 TOP OF VALVE BOX TO BE INSTALLED 3" ABOVE FINISH GRADE IN PLANTER AREAS,  
 AND EVEN WITH FINISH SURFACE OF MULCH.

NOT TO SCALE

|   |   |   |                                     |
|---|---|---|-------------------------------------|
|  | RECOMMENDED:<br> 1.16.14<br>DIVISION MANAGER DATE                    | <b>CITY OF MORENO VALLEY</b><br>FINANCIAL & MANAGEMENT SERVICES DEPARTMENT - SPECIAL DISTRICTS DIVISION | STANDARD PLAN<br><b>MVLI-574J-0</b> |
|   | APPROVED:<br> 1/29/14<br>PUBLIC WORKS DIRECTOR DATE<br>CITY ENGINEER | <b>AUTOMATIC FLUSH VALVE<br/>                 (FOR DRIPPERLINE)</b>                                     | SHEET 10 OF 12                      |

Attachment: SPECIAL PROVISIONS - MVCP SKATE PARK (3355) : APPROVE AND EXECUTE AGREEMENT WITH MICON CONSTRUCTION FOR

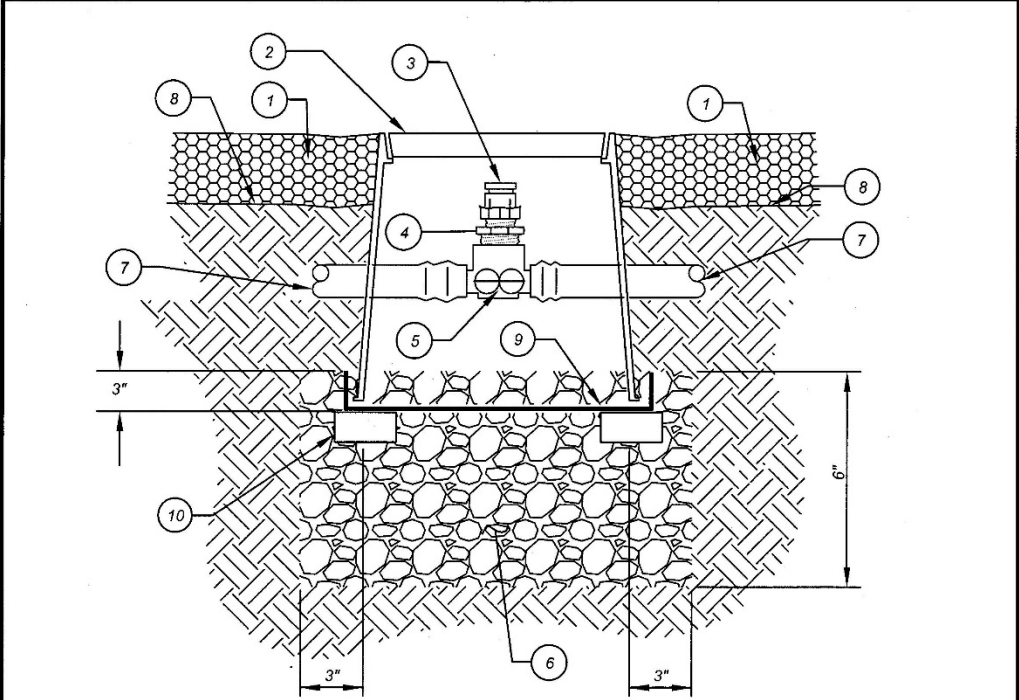

- 1 FINISH SURFACE OF MULCH (3" THICK)
- 2 6" ROUND VALVE BOX. SEE NOTE BELOW
- 3 AIR / VACUUM RELIEF VALVE
- 4 3/4" M x 1/2" F REDUCTION BUSHING
- 5 DRIPPERLINE COMBINATION TEE (1/2" x 1/2" x 3/4" FPT)
- 6 3/4" GRAVEL SUMP
- 7 DRIPPERLINE TUBING: FROM SURFACE INTO BOX TYPICAL
- 8 SOIL SURFACE FINISH GRADE, 3"-4" COVER OVER PIPE
- 9 1/4" GALVANIZED WIRE MESH
- 10 CONCRETE PAVER SUPPORT (3 PER BOX)

**NOTE:**

TOP OF VALVE BOX TO BE INSTALLED 3" ABOVE FINISH GRADE IN PLANTER AREAS, AND EVEN WITH FINISH SURFACE OF MULCH.

NOT TO SCALE

|   |   |   |                                     |
|---|---|---|-------------------------------------|
|  | RECOMMENDED:<br><br>DIVISION MANAGER      DATE                 | <b>CITY OF MORENO VALLEY</b><br>PARKS AND COMMUNITY SERVICES DEPARTMENT | STANDARD PLAN<br><b>MVLI-574L-1</b> |
|   | APPROVED:<br><br>PUBLIC WORKS DIRECTOR / DATE<br>CITY ENGINEER | <b>AIR / VACUUM RELIEF VALVE<br/>                 (FOR DRIPPERLINE)</b> | SHEET 12 OF 12                      |

Attachment: SPECIAL PROVISIONS - MVCP SKATE PARK (3355) : APPROVE AND EXECUTE AGREEMENT WITH MICON CONSTRUCTION FOR



**LEGEND:**

- ① JUMBO OR LARGER RECTANGULAR VALVE BOX PER SPECS
- ② STANDARD RECTANGULAR VALVE BOX PER SPECS
- ③ 10" DIA ROUND VALVE BOX
- ④ EDGE OF AREA, CURB, WALK OR WALL

PLAN

SAMPLE:  
POTABLE WATER SYSTEM OF  
CONTROLLER "A" REMOTE CONTROL  
VALVE ON STA No 9

|                |                 | IDENTIFICATION GUIDE |                       |
|----------------|-----------------|----------------------|-----------------------|
| DOMESTIC WATER | RECLAIMED WATER | CONTROLLER           | EQUIPMENT DESIGNATION |
| DIW            | RW              | A                    | ARV                   |
| DIW            | RW              | A                    | BS                    |
| DIW            | RW              | A                    | BV                    |
| DIW            | RW              | A                    | CCC                   |
| DIW            | RW              | A                    | DF                    |
| DIW            | RW              | A                    | FS                    |
| DIW            | RW              | A                    | FVA                   |
| DIW            | RW              | A                    | GR                    |
| DIW            | RW              | A                    | GV                    |
| DIW            | RW              | A                    | HB                    |
| DIW            | RW              | A                    | MS                    |
| DIW            | RW              | A                    | MV                    |
| DIW            | RW              | A                    | PB                    |
| DIW            | RW              | A                    | (STA NO.)             |
| DIW            | RW              | A                    | QC                    |

CONTACT PARKS AND COMMUNITY SERVICES FOR INFO ON ANY DEVICE IN A BOX NOT LISTED.

**CITY OF MORENO VALLEY**  
PARKS AND COMMUNITY SERVICES DEPARTMENT

NOT TO SCALE

RECOMMENDED:  
*[Signature]* 1/21/14  
DIVISION MANAGER DATE

APPROVED:  
*[Signature]* 1/29/14  
PUBLIC WORKS DIRECTOR / DATE  
CITY ENGINEER

**BOX IDENTIFICATION**

STANDARD PLAN  
**MVLI-581-0**

SHEET 1 OF 1



**NOTES:**

- A- VALVE BOXES SHALL BE LABELED BY HOT IRON BRANDING, 2" LETTERS/NUMBERS
- B- CONTROL VALVES SHALL BE INSTALLED TO ALLOW ORDERLY ARRANGEMENT OF VALVE BOXES
- C- WHERE POSSIBLE LOCATE VALVE ASSEMBLIES IN SHRUB OR GROUND COVER AREAS ONLY 12" FROM HARDSCAPE.
- D- LOCATION OF VALVE ASSEMBLIES SHALL BE STAKED FOR APPROVAL BY LANDSCAPE ARCHITECT PRIOR TO INSTALLATION.
- E- CENTER VALVE BOXES OVER VALVE ASSEMBLY TO FACILITATE ACCESS AND MAINTENANCE
- F- SET VALVE BOXES AT EQUAL ELEVATIONS W/ TOPS AT 3" ABOVE FINISH GRADE IN SHRUB/ GROUND COVER AREAS.
- G- VALVE BOXES SHALL BE SET PARALLEL TO EACH OTHER AND PERPENDICULAR TO EDGE OF AREA.
- H- DO NOT DEFORM OR COLLAPSE VALVE BOX BY EXCESSIVE SOIL COMPACTION AROUND BOX.
- I- SEE ALSO INDIVIDUAL VALVE INSTALLATION DETAILS.

**DEPARTMENT OF PARKS AND COMMUNITY SERVICES GENERAL NOTES:**

- A. ALL WORK SHALL BE DONE IN ACCORDANCE WITH THE MOST RECENT VERSIONS (AT TIME OF CONSTRUCTION) OF : THE CITY OF MORENO VALLEY PARK AND COMMUNITY SERVICES LANDSCAPE DEVELOPMENT GUIDELINES, SPECIFICATIONS, DRAWINGS, GREENBOOK SPECIFICATIONS FOR PUBLIC WORKS PROJECTS, AND THE CALIFORNIA BUILDING CODE.
- B. TURF AREAS SHALL HAVE A MAXIMUM DESIGN SLOPE OF 20% AND A MINIMUM DESIGN OF 1%.
- C. ALL CONCRETE SHALL ADHERE TO THE "GREENBOOK" FOR ITS SPECIFIC TYPE OF APPLICATION. MINIMUM REQUIREMENTS ARE 3250 PSI WITH NO SUBSTITUTES FOR PORTLAND CEMENT. COLOR AND FINISH SAMPLES SHALL BE PROVIDED TO THE PARKS AND COMMUNITY SERVICES PROJECT MANAGER FOR APPROVAL PRIOR TO INSTALLATION. PUMP MIXES SHALL BE 4000 PSI.
- D. CONTRACTOR / DEVELOPER SHALL PROVIDE A 12", #4 REINFORCED CONCRETE MOW STRIP BETWEEN TURF AND GROUND COVER AND A 12" CONCRETE MOW STRIP BETWEEN TURF AND WALLS, UNLESS SPECIFICALLY AUTHORIZED OTHERWISE BY PARKS AND COMMUNITY SERVICES.
- E. THE CONTRACTOR IS RESPONSIBLE FOR OBTAINING GRADING AND BUILDING PERMITS PRIOR TO COMMENCING CONSTRUCTION. PARKS AND COMMUNITY SERVICES WILL OBTAIN BUILDING PERMITS FOR CITY FUNDED PROJECTS.
- F. THE CONTRACTOR MUST NOTIFY THE PARKS AND COMMUNITY SERVICES PROJECT MANAGER AND THE BUILDING AND SAFETY DIVISION A MINIMUM OF TWO (2) WORKING DAYS (MONDAY - FRIDAY, EXCLUDING HOLIDAYS) PRIOR TO COMMENCING CONSTRUCTION AND / OR INSPECTION.
- G. ALL CONSTRUCTION WORK SHALL BE PERFORMED MONDAY THROUGH FRIDAY (EXCLUDING HOLIDAYS), BETWEEN THE HOURS OF 7 AM AND 4 PM. ANY EXCEPTIONS TO THIS SCHEDULE MUST BE APPROVED IN WRITING FROM PARKS AND COMMUNITY SERVICES.
- H. LANDSCAPE OR IRRIGATION CONTRACTOR SHALL VERIFY EXISTING WATER PRESSURE AT THE JOB SITE PRIOR TO INSTALLING LANDSCAPE IRRIGATION SYSTEM. A GAUGE THAT RECORDS MAINLINE PRESSURE AND FLOW IS REQUIRED FOR 24 HOUR / 7 DAY PERIOD.
- I. A MAINLINE TEST (IRRIGATION AND PORTABLE WATER) AT 150 PSI FOR 4 HOURS SHALL BE SCHEDULED WITH PARKS AND COMMUNITY SERVICES. IF WATER PRESSURE IS LESS THAN DESIGNED PRESSURE, THE CONTRACTOR WILL CONTACT THE ARCHITECT REGARDING THE FINDINGS AND WILL CEASE IRRIGATION WORK UNTIL A SOLUTION IS PROVIDED AND APPROVED IN WRITING BY THE PARKS AND COMMUNITY SERVICES PROJECT MANAGER. MAINLINE TESTS MUST HAVE ALL APPURTENANCES ATTACHED (VALVES, UNIONS, ETC.)
- J. THE CONTRACTOR IS RESPONSIBLE FOR INSTALLING AN IRRIGATION SYSTEM THAT PROVIDES COMPLETE COVERAGE TO PLANT MATERIAL IN A MATURE STAGE. IRRIGATION MODIFICATIONS MAY BE REQUIRED TO KEEP WATER OFF OF LIGHT FIXTURES, DRINKING FOUNTAINS, PLAY EQUIPMENT, PICNIC AREAS, STRUCTURES, FENCING, SIDEWALKS, ETC.
- K. AT THE CONCLUSION OF ROUGH GRADING, AGRONOMIC SOILS TESTING SHALL BE PROVIDED FOR THE PUBLIC LANDSCAPED AREA AND AREAS THAT ARE ADJACENT TO PUBLIC RIGHT-OF-WAY AND THE RESULTS APPROVED BY PARKS AND COMMUNITY SERVICES, PRIOR TO ANY LANDSCAPE INSTALLATION.
- L. A COMPREHENSIVE SOILS TEST IS REQUIRED PRIOR TO PLACING ANY CONCRETE (PCG OR AC) AND BACK FILLED TRENCHES. THIS WILL BE USED TO DETERMINE THE CONCRETE DESIGN AND NECESSITY OF ADDITIONAL BASE MATERIALS ABOVE THE DESIGN ON THE PLANS AND CITY STANDARDS. THE PLAN DESIGN AND CITY STANDARDS SHALL SET THE MINIMUM STANDARDS.
- M. ALL LOAD TICKETS OR RECEIPTS SHALL BE PROVIDED TO PARKS AND COMMUNITY SERVICES WITHIN 24 HOURS OF RECEIPT OF PRODUCT. COPIES OF LOAD TICKETS / RECEIPTS INCLUDE BUT ARE NOT LIMITED TO CONCRETE; SOIL AND LANDSCAPE PRODUCTS; PLANT MATERIAL; FENCING AND BUILDING MATERIALS.
- N. ALL 'SUBMITTALS' AND SHOP DRAWINGS SHALL BE PROVIDED TO PARKS AND COMMUNITY SERVICES WITHIN THE FIRST 30-DAYS OF THE AWARD OF CONTRACT.
- O. ALL MATERIALS SHALL BE AS SPECIFIED WITHIN THE PLANS AND SPECIFICATIONS. 'EQUALS OR SUBSTITUTIONS' WILL ONLY BE CONSIDERED WITHIN THE FIRST 30-DAYS AFTER THE AWARD OF CONTRACT. THE PARKS AND COMMUNITY SERVICES PROJECT MANAGER SHALL APPROVE IN WRITING ALL 'EQUALS OR SUBSTITUTIONS'. THE CONTRACTOR SHALL REPLACE AT THE CONTRACTOR'S COST ANY PRODUCT UTILIZED THAT HAS NOT BEEN APPROVED IN WRITING BY THE PARKS AND COMMUNITY SERVICES PROJECT MANAGER.
- P. THE CONTRACTOR SHALL COORDINATE WITH AND NOTIFY THE PARKS AND COMMUNITY SERVICES PROJECT MANAGER OF THE REQUIRED PRE-CONSTRUCTION MEETING TO BE HELD ON SITE.
- Q. THE CONTRACTOR OR DEVELOPER SHALL GUARANTEE ALL MATERIALS AND WORKMANSHIP FOR A PERIOD OF ONE (1) YEAR AFTER PARKS AND COMMUNITY SERVICES ACCEPTS THE SITE IMPROVEMENTS.
- R. THE CONTRACTOR OR DEVELOPER SHALL MAINTAIN ALL LANDSCAPING FOR A PERIOD OF ONE (1) YEAR AFTER THE PARKS AND COMMUNITY SERVICES HAS ACCEPTED ALL IMPROVEMENTS FOR MAINTENANCE WITHIN COMMUNITY SERVICES DISTRICTS. BOND'S SHALL BE REQUIRED IN THE AMOUNT TO COVER THE WORK. CITY FUNDED PROJECTS ARE EXEMPT FROM THIS REQUIREMENT.

NOT TO SCALE

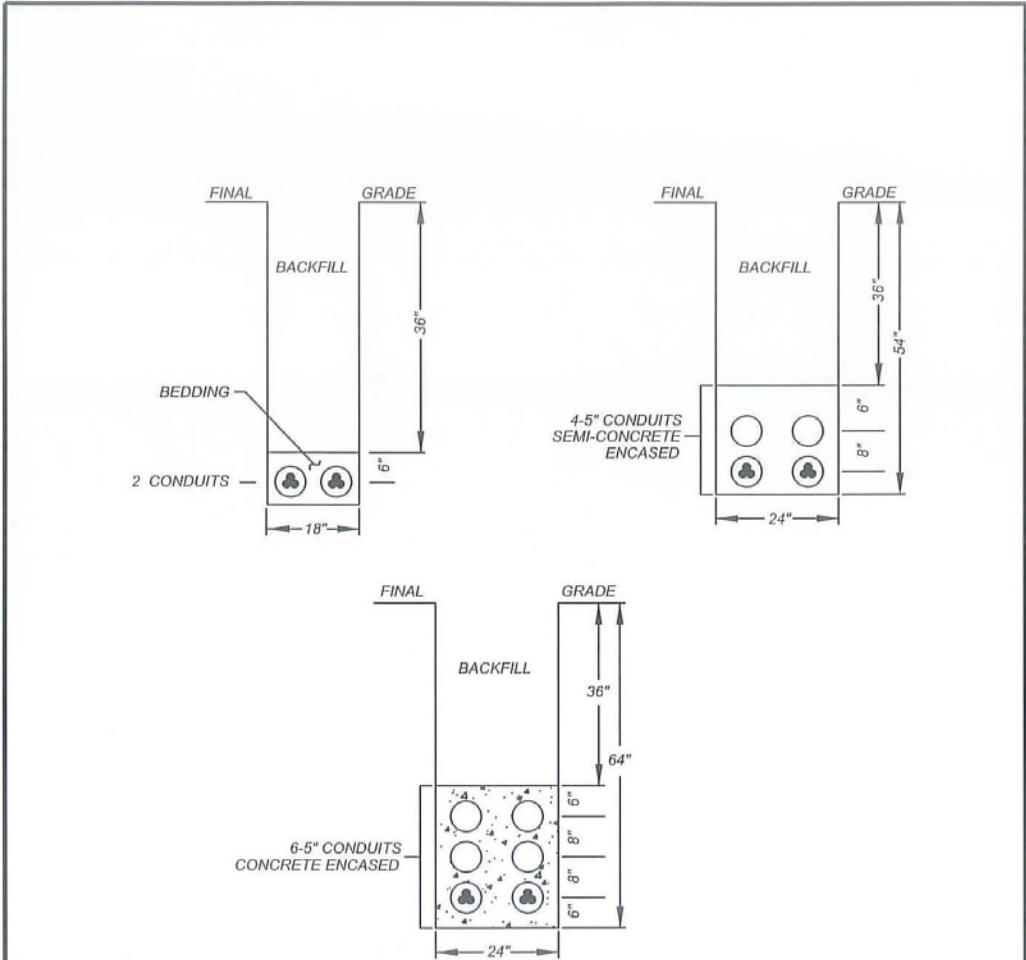

|   |   |  |  |
|---|---|--|--|
|  | RECOMMENDED:<br> | CITY OF MORENO VALLEY<br>PARKS AND COMMUNITY SERVICES DEPARTMENT<br><br><b>PARKS AND COMMUNITY SERVICES<br/>                 GENERAL NOTES</b> | STANDARD PLAN<br><b>MVGF-600-0</b>   |
|   | DIVISION MANAGER<br>DATE: 1/21/14   |  | APPROVED:<br> |
|   | PUBLIC WORKS DIRECTOR /<br>CITY ENGINEER<br>DATE: 1/29/14   |  |  |



**NOTES:**

- 1.) BEDDING MATERIAL SHALL BE CLEAN SAND OR PEA GRAVEL. OTHERWISE, NATIVE MATERIALS MAY BE USED PROVIDED THEY MEET PUBLIC WORKS CONSTRUCTION (GREEN BOOK) STANDARDS PER SUBSECTION 306.1.2.1 AND MUST HAVE A SAND EQUIVALENT OF NOT LESS THAN 30 OR HAVING A COEFFICIENT OF PERMEABILITY GREATER THAN 1.4 INCHES/HR.
- 2.) CONDUITS ARE DB, EB, OR SCH 40 DEPENDING ON APPLICATION PER PLAN.
- 3.) CONCRETE SHALL BE TWO SACK ENCASEMENT.

NOT TO SCALE

|   |   |   |                                     |
|---|---|---|-------------------------------------|
|  | RECOMMENDED:<br> 1/23/14<br>DIVISION MANAGER DATE                      | <b>CITY OF MORENO VALLEY</b><br>PARKS AND COMMUNITY SERVICES DEPARTMENT       |                                     |
|   | APPROVED:<br> 1/29/14<br>PUBLIC WORKS DIRECTOR / DATE<br>CITY ENGINEER | <b>TRENCH DETAILS FOR CONDUIT<br/>                 INSTALLATIONS IN PARKS</b> | STANDARD PLAN<br><b>MVGF-618B-0</b> |
|   | SHEET 2 OF 2  |   |                                     |

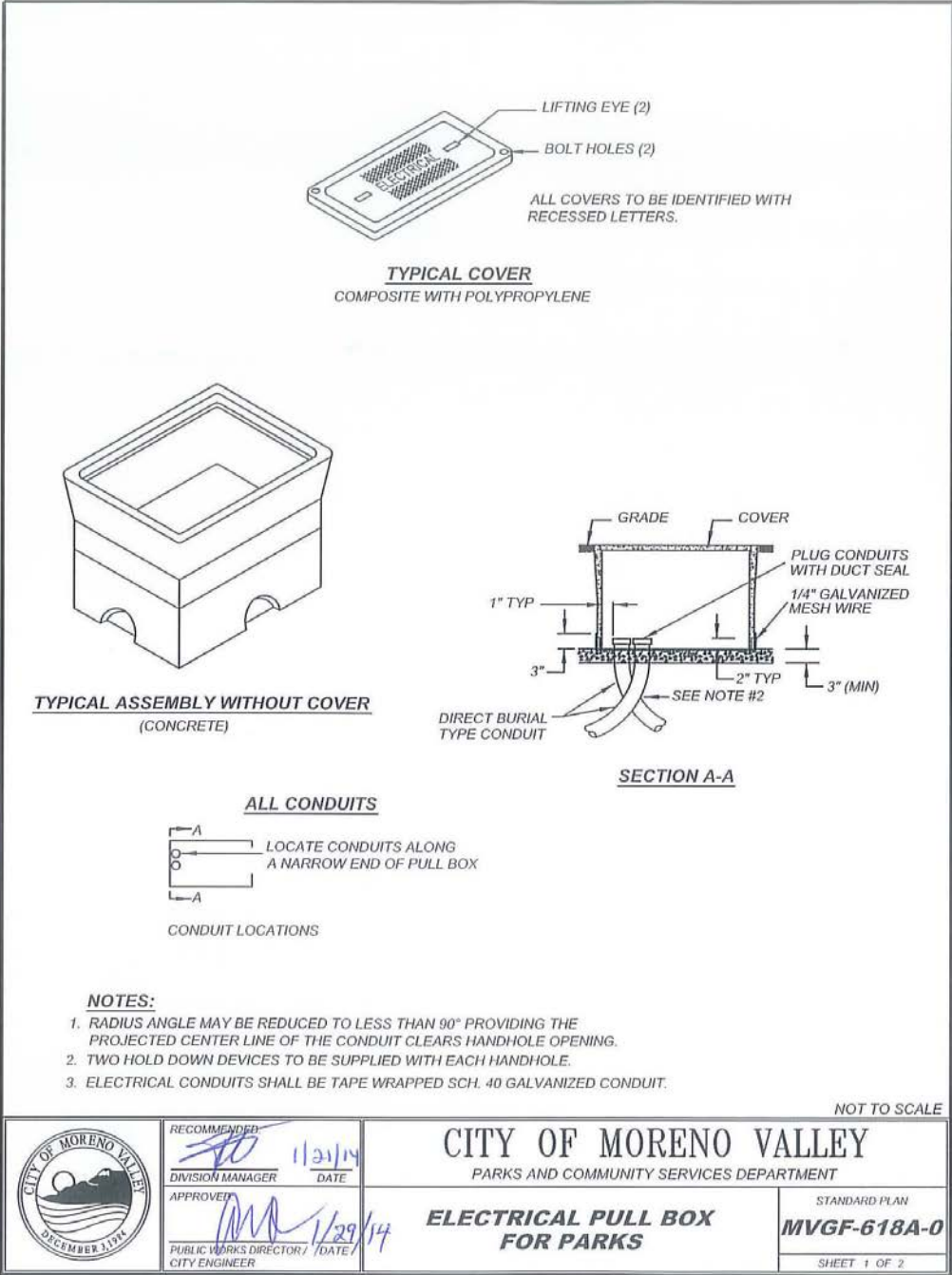

**APPENDIX C**  
**CERTIFIED PAYROLL FORM**

Attachment: SPECIAL PROVISIONS - MVCP SKATE PARK (3355 : APPROVE AND EXECUTE AGREEMENT WITH MICON CONSTRUCTION FOR

**PUBLIC WORKS PAYROLL REPORTING FORM**



Page \_\_\_\_\_ of \_\_\_\_\_

| NAME OF CONTRACTOR OR SUBCONTRACTOR:                        |                                       | ADDRESS:                   |                      | CONTRACTOR'S LICENSE NO.:     |                           | SPECIALTY LICENSE NO.:            |   | PROJECTOR CONTRACT NO.: |           | PROJECT AND LOCATION: |              |                       |           |                |            |        |             |         |             |                   |        |                   |  |  |  |
|---|---------------------------------------|----------------------------|----------------------|-------------------------------|---------------------------|-----------------------------------|---|-------------------------|-----------|-----------------------|--------------|-----------------------|-----------|----------------|------------|--------|-------------|---------|-------------|-------------------|--------|-------------------|--|--|--|
| PAYROLL NO.:  |                                       | FOR WEEK ENDING:           |                      | SELF-INSURED CERTIFICATE NO.: |                           | WORKERS' COMPENSATION POLICY NO.: |   | (6)                     |           | (9)                   |              |                       |           |                |            |        |             |         |             |                   |        |                   |  |  |  |
| (1)<br>NAME, ADDRESS AND SOCIAL SECURITY NUMBER OF EMPLOYEE | (2)<br>NO. OF WITH-HOLDING EXEMPTIONS | (3)<br>WORK CLASSIFICATION | (4)<br>M T W T F S S | (5)<br>DATE                   | (6)<br>HOURLY RATE OF PAY | (7)<br>GROSS AMOUNT EARNED        | (8)<br>DEDUCTIONS, CONTRIBUTIONS AND PAYMENTS |                         |           |                       |              | NET WGS PAID FOR WEEK | CHECK NO. |                |            |        |             |         |             |                   |        |                   |  |  |  |
|   |                                       |                            |                      |                               |                           |                                   | FED. TAX                                      | FGCA (SOC. SEC.)        | STATE TAX | SIH                   | VAC/ HOLIDAY |                       |           | HEALTH & WELF. | PENSION    | TRAING | FUND ADMIN  | DUES    | TRAV/ SUBS. | SAVINGS           | OTHER* | TOTAL DEDUC-TIONS |  |  |  |
|   |                                       | THIS PROJECT               |                      |                               | ALL PROJECTS              |                                   | FED. TAX                                      | FGCA (SOC. SEC.)        | STATE TAX | SIH                   | VAC/ HOLIDAY | HEALTH & WELF.        | PENSION   | TRAING         | FUND ADMIN | DUES   | TRAV/ SUBS. | SAVINGS | OTHER*      | TOTAL DEDUC-TIONS |        |                   |  |  |  |
|   |                                       | S                          |                      |                               |                           |                                   |   |                         |           |                       |              |                       |           |                |            |        |             |         |             |                   |        |                   |  |  |  |
|   |                                       | O                          |                      |                               |                           |                                   |   |                         |           |                       |              |                       |           |                |            |        |             |         |             |                   |        |                   |  |  |  |
|   |                                       | S                          |                      |                               |                           |                                   |   |                         |           |                       |              |                       |           |                |            |        |             |         |             |                   |        |                   |  |  |  |
|   |                                       | O                          |                      |                               |                           |                                   |   |                         |           |                       |              |                       |           |                |            |        |             |         |             |                   |        |                   |  |  |  |
|   |                                       | S                          |                      |                               |                           |                                   |   |                         |           |                       |              |                       |           |                |            |        |             |         |             |                   |        |                   |  |  |  |
|   |                                       | O                          |                      |                               |                           |                                   |   |                         |           |                       |              |                       |           |                |            |        |             |         |             |                   |        |                   |  |  |  |

Form A-1-13 (New 2-80) S = STRAIGHT TIME O = OVERTIME SEI = STATE DISABILITY INSURANCE \*OTHER - Any other deductions, contributions and/or payments whether or not included or required by prevailing wage determinations must be separately listed. Use extra sheet(s) if necessary. CERTIFICATION MUST be completed (See reverse side)

**NOTICE TO PUBLIC ENTITY**

**For Privacy Considerations**

**Fold back along dotted line prior to copying for release to general public (private persons).**

(Paper Size then 8-1/2 x 11 inches)



I, \_\_\_\_\_, the undersigned, am the  
(Name – print)

\_\_\_\_\_ with the authority to act for and on behalf of  
(Position in business)

\_\_\_\_\_, certify under penalty of perjury  
(Name of business and/or contractor)

that the records or copies thereof submitted and consisting of \_\_\_\_\_  
(Description, number of pages)

are the originals or true, full, and correct copies of the originals which depict the payroll record(s)  
of the actual disbursements by way of cash, check, or whatever form to the individual or  
individuals named.

Date: \_\_\_\_\_ Signature: \_\_\_\_\_

A public entity may require a stricter and/or more extensive form of certification.

Attachment: SPECIAL PROVISIONS - MVCP SKATE PARK (3355 : APPROVE AND EXECUTE AGREEMENT WITH MICON CONSTRUCTION FOR

**APPENDIX D**  
**SOLID WASTE DISPOSAL AND RECYCLING REPORTS**

Attachment: SPECIAL PROVISIONS - MVCP SKATE PARK (3355 : APPROVE AND EXECUTE AGREEMENT WITH MICON CONSTRUCTION FOR



City of Moreno Valley  
**SOLID WASTE DISPOSAL AND RECYCLING REPORT - INSTRUCTIONS**

|   |
|---|
| <p><b>Section 1: To be completed by the contractor</b></p> <p><b>Project Name:</b> Give a brief description of the project.</p> <p><b>Type of Work:</b> Enter a general work description, e.g. "AC Grinding" Widening, Reconstruction, Overlay</p> <p><b>Ongoing Report:</b> Checking this box means this is a report for a continuing project. More monthly reports will follow.</p> <p><b>Final Report:</b> Checking this box means this is the last report before contract acceptance.</p> <p><b>Project Number:</b> Enter Project Number<br/> <small>(Reports are monthly from the beginning of the month until the contract is completed. Separate reports are needed for each month).</small></p> <p><b>Company Information:</b> Contractor Name, Phone Number, Fax Number, Street Address, City, State and Zip</p> <p><b>Contractor Certification:</b> I certify under penalty of perjury that the information provided in this form is complete and accurate.</p> <p>Contractor should verify the data entered on this form, then sign the report and print your name, title, and date.<br/> Return this report to the project engineer by the 10th of the following month or within 15 days of final work.</p>   |
| <p><b>Section 2: To be completed by the contractor</b></p> <p>To count towards diversion, "solid waste" is defined as including any solid waste which would normally be disposed of at a disposal facility (PRC Section 41781 (b))</p> <p><b><u>NAME AND LOCATION OF RECYCLING OR DISPOSAL FACILITY (or enter "reused" for materials generated and reused on this job)</u></b><br/> Each address should be checked as either <u>landfill</u> or <u>recycler</u>. When using a recycling facility that exists inside a landfill, check recycler and do not check landfill. When the solid waste is generated and reused on the job, the word "Reused" should be entered in place of the address.</p> <p><b><u>TYPE OF MATERIAL</u></b> Please enter a number for each activity one per line:<br/> 1 = Source-Separated Materials Recycling; 2 = On-Site Reuse; 3 = Mixed Debris Recycling; 4 = Reuse of Salvageable Items; 5 = Disposal at Landfill 6 = Transfer Station; 7 = Other [Describe the activity when "Other" is selected]<sup>1</sup></p> <p><b><u>AMOUNT TAKEN TO LANDFILL</u></b> (Tons): Enter the amount of any solid waste, in tons, that is generated on this project and taken to a landfill and attach copies of weight tickets.</p> <p><b><u>AMOUNT DIVERTED FROM LANDFILLS TO A RECYCLING FACILITY</u></b> (Tons): Enter the amount of any solid waste, in tons, that is generated on this project and taken to a recycling facility and attach copies of weight tickets.<br/> Solid waste from this job that is used in other projects, given to other agencies (county, city etc.) or given to private individuals for reuse will be entered as taken to a recycling facility. In this case, check the activity as "Other" and describe who gets the solid waste in the row for other activity. (e.g. given to county, city or developer)</p> <p><b><u>AMOUNT GENERATED AND THEN REUSED ON THIS JOB</u></b> (Tons): Enter the amount of any solid waste, in tons, that is generated on this project and reused.</p> <p><b><u>TOTAL (TONS)</u></b> Total amount taken to landfill + amount recycled + amount reused.</p> <p><b><u>% DIVERTED</u></b> Total recycled + total reused + total tons x 100</p> <p>These conversion factors may be found at the California Integrated Waste Management Board's (CIWMB) web site at:<br/> <a href="http://www.ciwmb.ca.gov/LGLibrary/DSG/Appendix.htm#Conversion">http://www.ciwmb.ca.gov/LGLibrary/DSG/Appendix.htm#Conversion</a></p> |
| <p><b>Section 3: To be completed by the project engineer</b></p> <p>I have reviewed the information submitted in this report for completeness.</p> <p>Project engineer please review the report. If the form is complete, sign and print your name, phone number, and date. Discuss and resolve with the contractor any deficiency on the form.</p> <p>The project engineer shall submit the completed form to the appropriate City representative by the 20th of the following month or within 30 days of final work.</p>  |

City of Moreno Valley  
PUBLIC IMPROVEMENT  
MONTHLY SOLID WASTE DISPOSAL AND RECYCLING REPORT

|  |  |                   |  |  |                                 |   |   |              |            |
|--|--|-------------------|--|--|---------------------------------|---|---|--------------|------------|
| Project Name:  | Project Number: <input type="checkbox"/> Ongoing Report <input type="checkbox"/> Final Report <input type="checkbox"/> |                   |  |  |                                 |   |   |              |            |
|  | Report for Month/Year:   |                   |  |  |                                 |   |   |              |            |
| Contractor Name  | Fax:   |                   |  |  |                                 |   |   |              |            |
| Street Address   | City, State, Zip   |                   |  |  |                                 |   |   |              |            |
| Contractor Certification: I certify under penalty of perjury that the information provided in this form is complete and accurate.  |  |                   |  |  |                                 |   |   |              |            |
| Signature  | Date of Report:  |                   |  |  |                                 |   |   |              |            |
| <p><b>*NOTE: Earth and Rock material must not be reported as either waste material diverted from or disposed to landfills.</b></p> <p>NAME AND LOCATION OF RECYCLING OR DISPOSAL FACILITY (OR ENTER "REUSED" FOR MATERIALS GENERATED AND REUSED ON THIS JOB)</p> |  |                   |  |  |                                 |   |   |              |            |
| 1  | CHECK IF LANDFILL  | CHECK IF RECYCLER | TYPE OF MATERIAL<br>(Please enter a letter for each type on a separate line):<br>A = Asphalt Concrete;<br>B = Building Material;<br>C = Portland Cement Concrete;<br>M = Metal;<br>D = Mixed Debris;<br>W = Wood/Cleaned Vegetation;<br>O = Other (Please Describe);<br>See note above | TYPE OF ACTIVITY<br>(Please enter one activity per line):<br>1 = Source - Separated Materials Recycling<br>2 = On-Site Reuse<br>3 = Mixed Debris Recycling Items<br>4 = Reuse of Salvageable<br>5 = Disposal at Landfill<br>6 = Transfer to Station<br>7 = Other (Please Describe) | AMOUNT TAKEN TO LANDFILL (TONS) | AMOUNT DIVERTED FROM LANDFILLS TO A RECYCLING FACILITY (TONS) | AMOUNT GENERATED AND THEN REUSED ON THIS JOB (TONS) | TOTAL (TONS) | % DIVERTED |
| 2  |  |                   |  |  |                                 |   |   |              |            |
| <b>TOTAL</b>   |  |                   |  |  |                                 |   |   |              |            |
| I have reviewed the formaion submitted in this report for completeness.  |  |                   |  |  |                                 |   |   |              |            |
| 3  | Project Engineer (Please Print):   |                   | Phone Number:  |  |                                 |   |   |              |            |
|  | Signature:   |                   | Date:  |  |                                 |   |   |              |            |

City of Moreno Valley  
 PUBLIC IMPROVEMENT  
**DAILY/WEEKLY SOLID WASTE RECYCLING REPORT**  
 Project Name: (Insert Name)  
 Project No.: (Insert Number)

Month/Year: \_\_\_\_\_

Page \_\_\_ of \_\_\_

Type of Material: \_\_\_\_\_

Contractor/Subcontractor: \_\_\_\_\_

| Date              | Name & Location of Recycling Facility | Tons |
|-------------------|---------------------------------------|------|
| Monday            |                                       |      |
| Tuesday           |                                       |      |
| Wednesday         |                                       |      |
| Thursday          |                                       |      |
| Friday            |                                       |      |
| Saturday          |                                       |      |
| <b>Week Total</b> |                                       |      |

City of Moreno Valley  
Public Improvement  
DAILY SOLID WASTE RECYCLING REPORT

Project Name: (Insert Name)

Project No.: (Insert Number)

Date: \_\_\_\_\_

Contractor: \_\_\_\_\_

Subcontractor: \_\_\_\_\_

Month/Year: \_\_\_\_\_

| Material  | To Landfill (Tons) | Recycled (Tons) | Resused (Tons) | Disposed (tons) | Total Quantity Generated (Tons) | Facility Used/Destination  |
|---|--------------------|-----------------|----------------|-----------------|---------------------------------|--|
|   | A                  | B               | C              | A+B             | A+B+C                           |  |
|   | Weight             | Weight          | Weight         | Weight          | Weight                          |  |
| Example: Dirt                                     | 5 tons             | 5 tons          | 9.5 tons       | 10 tons         | 24.5 tons                       | Recycle - Azusa Land Reclamation<br>Reuse - On Job Site for Grading<br>Dispose - Puente Hills Landfill |
| Asphalt Concrete                                  |                    |                 |                |                 |                                 |  |
| Brick   |                    |                 |                |                 |                                 |  |
| Building Materials (ceiling tile, fixtures, etc.) |                    |                 |                |                 |                                 |  |
| Cardboard, paper                                  |                    |                 |                |                 |                                 |  |
| Carpet/Carpet Padding                             |                    |                 |                |                 |                                 |  |
| Concrete (PCC)                                    |                    |                 |                |                 |                                 |  |
| Dirt  |                    |                 |                |                 |                                 |  |
| Glass   |                    |                 |                |                 |                                 |  |
| Green Waste                                       |                    |                 |                |                 |                                 |  |
| Gypsum/Dry Wall                                   |                    |                 |                |                 |                                 |  |
| Metals  |                    |                 |                |                 |                                 |  |
| Mixed C&D (commingled, recyclable)                |                    |                 |                |                 |                                 |  |
| Plastic   |                    |                 |                |                 |                                 |  |
| Rock  |                    |                 |                |                 |                                 |  |
| Roofing   |                    |                 |                |                 |                                 |  |
| Tile (ceramic)                                    |                    |                 |                |                 |                                 |  |
| Wood (lumber, doors, etc.)                        |                    |                 |                |                 |                                 |  |
| Refuse  |                    | NA              | NA             | NA              |                                 |  |
| Other   |                    |                 |                |                 |                                 |  |
| <b>Totals</b>                                     |                    |                 |                |                 |                                 |  |

Use your daily weight receipts to fill in the table below and submit receipts attached with this form.

Total Recycled \_\_\_\_\_ + Total Reused \_\_\_\_\_ = \_\_\_\_\_ ÷ Total Quantity Generated \_\_\_\_\_ x 100 = \_\_\_\_\_ %

City of Moreno Valley  
Public Improvement  
DAILYWEEKLY SOLID WASTE RECYCLING REPORT

Use your daily weight receipts to fill in the table below and submit receipts attached with this form.

Project Name:

Contractor:

Project No.

Subcontractor:

Month/Year:

| Material  | Recycled |        | Resused           |          | Disposed (tons) | Total Quantity Generated | Facility Used/Destination  |
|---|----------|--------|-------------------|----------|-----------------|--------------------------|--|
|   | Volume   | Weight | Volume            | Weight   |                 |                          |  |
| Example: Dirt<br>10yd <sup>3</sup> = 18,900lbs            | NA       | 5 tons | 10yd <sup>3</sup> | 9.5 tons | 10 tons         | 24.5 tons                | Recycle - Azusa Land Reclamation<br>Reuse - on job site for grading<br>Dispose - Puente Hills Landfill |
| Asphalt<br>1yd <sup>3</sup> = 1,380lbs                    |          |        |                   |          |                 |                          |  |
| Brick<br>1yd <sup>3</sup> = 3,024lbs                      |          |        |                   |          |                 |                          |  |
| Building Materials (ceiling tile, fixtures, etc.)         |          |        |                   |          |                 |                          |  |
| Cardboard, paper<br>1yd <sup>3</sup> = 100lbs             |          |        |                   |          |                 |                          |  |
| Carpet/Carpet Padding<br>1yd <sup>3</sup> = 84.4lbs       |          |        |                   |          |                 |                          |  |
| Concrete<br>1yd <sup>3</sup> = 1,855lbs                   |          |        |                   |          |                 |                          |  |
| Dirt<br>10yd <sup>3</sup> = 18,900lbs                     |          |        |                   |          |                 |                          |  |
| Glass<br>1yd <sup>3</sup> = 2,160lbs                      |          |        |                   |          |                 |                          |  |
| Green Waste<br>40yd <sup>3</sup> = 4,320lbs               |          |        |                   |          |                 |                          |  |
| Gypsum/Dry Wall<br>1yd <sup>3</sup> = 3,834lbs            |          |        |                   |          |                 |                          |  |
| Metals<br>1yd <sup>3</sup> = 906lbs                       |          |        |                   |          |                 |                          |  |
| Mixed C&D (commingled, recyclable)                        |          |        |                   |          |                 |                          |  |
| Plastic<br>1yd <sup>3</sup> = 22.55lbs                    |          |        |                   |          |                 |                          |  |
| Rock<br>1yd <sup>3</sup> = 2,570lbs                       |          |        |                   |          |                 |                          |  |
| Roofing<br>1yd <sup>3</sup> = 418.5lbs                    |          |        |                   |          |                 |                          |  |
| Tile (ceramic)<br>1yd <sup>3</sup> = 1,214lbs             |          |        |                   |          |                 |                          |  |
| Wood (lumber, doors, etc.)<br>1yd <sup>3</sup> = 329.5lbs |          |        |                   |          |                 |                          |  |
| Refuse  | NA       | NA     | NA                | NA       |                 |                          |  |
| Other   |          |        |                   |          |                 |                          |  |
| <b>Totals</b>   |          |        |                   |          |                 |                          |  |

Total Recycled \_\_\_\_ + Total Reused \_\_\_\_ = \_\_\_\_ ÷ Total Quantity Generated \_\_\_\_ x 100 = \_\_\_\_ %

**APPENDIX E**

**DIG ALERT DELINEATION FOR UNDERGROUND SERVICE MARKINGS**

**MEMBERS! Be prepared...DigAlert Ticket format changes become effective Nov 1st, 2017**

**Also effective Nov 1st, 2017 Grid Notifications are no longer supported. Submit shapefiles today.**

(/)

## **Contact 811 Before You Dig**

Southern California's free and easy solution  
for safe excavation

## **California Law**

View CA Government Code 4216 (/calaw-full-2017)

## **California State Law Says, You Must Contact DigAlert Before You Dig!**

Failure to do so can result in fines up to fifty thousand dollars and you could be charged with the repair costs of damaged underground facility. Why risk it? Contact DigAlert before you dig and they will notify all of its members having underground facilities within the delineated area.

## **Important changes & highlights effective Jan 1<sup>st</sup> 2017**

- Delineation of the proposed excavation site is now mandatory. If the delineation could be misinterpreted as a traffic or pedestrian control, the excavator shall use pink markings and notify the center the delineation is in pink. (4216.2(a) & 4216 Definitions (d))

- Members can, at their own discretion, choose not to locate and field mark until the area to be excavated has been delineated. (4216.2(a))
- Contact DigAlert at least two (2) working days NOT including the date of notification (4216.2(b)) prior to digging.
- Any temporary marking placed at the planned excavation location shall be clearly seen, functional, and considerate to surface aesthetics and the local community. An excavator shall check if any local ordinances apply to the placement of temporary markings. (4216.2(d))
- Working day is defined as a weekday (M - F) from 7:00 am to 5 :00 pm, except for federal and state holidays as defined in Section 19853, or as otherwise posted on the Internet Web Site of the regional notification center. (4216 Definitions (v))
- Excavations shall not begin until the excavator receives a response from all known members within the delineated boundaries. (4216.2(g))
- If a ticket obtained by an excavator expires but work is ongoing, the excavator shall call into the regional notification center and get a new ticket and wait a minimum of two working days, not including the date of call in, before restarting excavation. All excavation shall cease during the waiting period.(4216.2(i))
- An operator shall indicate with an "A" inside a circle the presence of any abandoned subsurface installations, if known, within the delineated area. The markings are to make an excavator aware that there are abandoned subsurface installations within that delineated work area.(4216.3(a)(1) (A)(iii)(C))
- If the field marks are no longer reasonably visible, an excavator shall renotify the regional notification center with a request for remarks that can be for all or a portion of the excavation. Excavation shall cease in the area to be remarked. If the delineation markings are no longer reasonably visible, the excavator shall redelineate the area to be remarked. If remarks are requested, the operator shall have two working days, not including the date of request, to remark the subsurface installation. If the area to be remarked is not the full extent of the original excavation, the excavator shall delineate the portion to be remarked and provide a description of the area requested to be remarked on the ticket. The excavator shall provide a description for the area to be remarked that falls within the area of the original location request. (42216.3(b))
- The Law requires you to hand expose to the point of no conflict 24" on either side of the underground facility, so you know its exact location before using power equipment. (4216.4(a)(1))
- Your permit for digging will not be valid without a ticket number. (4216.9(a))
- The California Underground Facilities Safe Excavation Board is hereby created under, and shall be assisted by the staff of, the Office of the State Fire Marshal. (4216.12(a))



## Important changes effective Jan 1<sup>st</sup> 2018

- Members may supply an electronic positive response through the regional notification center before the legal excavation start date and time. The regional notification center shall make those responses available to the excavator. (4216.3 (b))

## Important changes effective July 1<sup>st</sup> 2018

- The board shall investigate possible violations of this article. (4216.19(a))

View the New 2017 California Law, Government Code 4216 (/calaw-full-2017)

## But I have an emergency and I need to dig now!

California law requires that you call two (2) working days, not including the date of notification, before your planned excavation. However, if you are digging because of an EMERGENCY, you are not required by law to call. You should still consider calling in order to prevent damaging any other underground lines near your EMERGENCY dig site. An EMERGENCY situation does not relieve you of financial responsibilities for damaging underground facilities.

However keep in mind that under 4216 Definitions (f)(1) states...

"Emergency" means a sudden, unexpected occurrence, involving a clear and imminent danger, demanding immediate action to prevent or mitigate loss of, or damage to, life, health, property, or essential public services.

(2) "Unexpected occurrence" includes, but is not limited to, a fire, flood, earthquake or other soil or geologic movement, riot, accident, damage to a subsurface installation requiring immediate repair, or sabotage.

## Digging without a DigAlert is just simply dangerous, not to mention illegal!

You can damage a basic telephone cable and disrupt service to a home or you may cut a fiber optic cable carrying millions of calls and expose your company to costly repairs. Plus there is the real possibility of an explosion from hitting a gas line or an electrocution from an electric line! Not only is expensive equipment ruined, but lives are put at risk.

## Learn More

[About DigAlert \(/about\)](#)

[Typical Projects \(/safe-digging#typical\\_projects\)](#)

[F.A.Q.s \(/faqs\)](#)

[Membership with USA/SC \(/members\)](#)

## Digging Resources

[CA State Law \(/calaw\)](#)

[CGA Best Practices \(/pdfs/bestpractices.pdf\)](#)

[Delineation Guide \(/delineation\)](#)

[APWA Color Codes \(/delineation#apwa\\_color\\_codes\)](#)

[Emergency Procedure \(/emergency-dig-process\)](#)

## Network with us!



<https://www.facebook.com/digalert>



<https://twitter.com/@digalert>



[https://www.instagram.com/digalert\\_official/](https://www.instagram.com/digalert_official/)



[https://www.linkedin.com/company/underground-service-alert-of-southern-](https://www.linkedin.com/company/underground-service-alert-of-southern-california-digalert-?report.success=KJ_KkFGTDCfMt-A7wV3Fn9Yvgwr02Kd6AZHGx4bQCDiP6-2rfP2oxyVoEQiPrcAQ7Bf)

[california-digalert-?report.success=KJ\\_KkFGTDCfMt-A7wV3Fn9Yvgwr02Kd6AZHGx4bQCDiP6-2rfP2oxyVoEQiPrcAQ7Bf](https://www.linkedin.com/company/underground-service-alert-of-southern-california-digalert-?report.success=KJ_KkFGTDCfMt-A7wV3Fn9Yvgwr02Kd6AZHGx4bQCDiP6-2rfP2oxyVoEQiPrcAQ7Bf)



(<https://youtube.com/digalert811>)



(<https://plus.google.com/104672045577396724214>)

© 2017

Underground Service Alert of Southern California.

All rights reserved.

[Terms of Service / Privacy Policy \(/tos\)](#)



## How to Delineate a Prospective Excavation Site

*This marking guide provides for uniform marking of the area to be excavated with white paint in paved surfaces, or in unpaved areas with other suitable markings such as stakes or flags.*

### White Paint Marking

In the case of a single excavation of known dimensions and location, delineate the exact area to be excavated with white paint through the use of dots or dashes, or a continuous solid line. Limit the size of each dash to 6 inches in length and 1 inch in width, with interval spacing not less than 48 inches between each dash. When using a solid line, limit its width to 1 inch. In either case, excavators must insure that their white paint marks cannot be misinterpreted as a traffic or pedestrian control.

In the case of numerous excavations or one long, continuous excavation, mark the center line of the excavation with arrows showing the direction of the excavation. Mark lateral excavation with an arrow

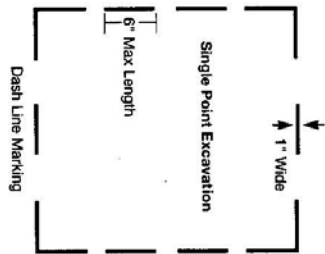
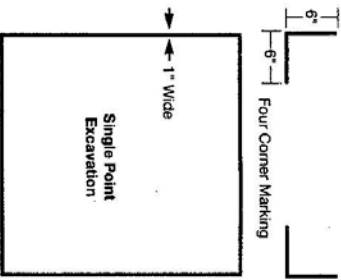

showing direction from the center line with an additional mark at the curb of property line. Limit the size of each arrow to 6 inches in length and 1 inch in width, with interval spacing not less than 48 inches between each arrow. When calling the regional notification center for locating, give the width of the excavation in number of feet either side of the center line of lateral marks.

The marked area of excavation should be identified by the name, initials or logo, in white paint, of the company planning to conduct the excavation.

Delineate the area to be excavated before calling the regional notification center. If this is impractical due to permit requirements or other restrictions, notify the center of the exact date and time the excavation will be delineated. This will assist the operators of subsurface installations in scheduling their field marking.

All excavators are reminded that premarking is a requirement of the California Code of Regulations, Section 4216 and 4217. Failure to premark when practical can jeopardize your permit, or result in civil penalties. If premarking is not practical, the excavator shall contact the regional notification center to advise the operators that the excavator shall identify the area to be excavated in another manner sufficient to enable the operator to determine the exact area of the excavation to be field marked.

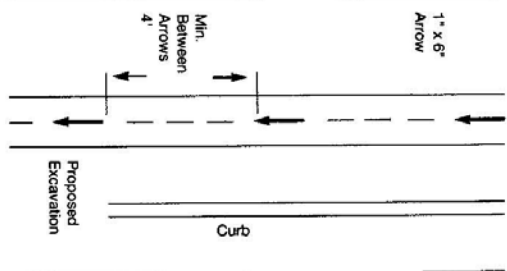

### Trench or Continuous Excavation

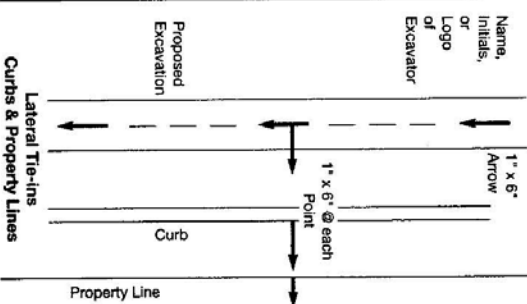

**APPENDIX F**  
**RED IMPORTED FIRE ANT COOPERATIVE AGREEMENT**

Attachment: SPECIAL PROVISIONS - MVCP SKATE PARK (3355 : APPROVE AND EXECUTE AGREEMENT WITH MICON CONSTRUCTION FOR

### **RED IMPORTED FIRE ANTS (RIFA)**

The City of Moreno Valley has areas of infestation of red imported fire ant colonies and has quarantine areas. Movement of earth within and from the quarantine areas is restricted to inspection and possible treatment. RIFA have been found to nest under cracked pavement, sidewalks, water meter boxes, pull boxes, and traffic signal cabinets along with other utilities within the right-of-way.

The Contractor shall notify the California Department of Food & Agriculture, Jose Reyes (760) 776-8208, or Riverside County Agricultural Commissioner before excavating or moving any earth or making a disturbance to the soil. The Contractor shall fill out and send a cooperative Red Imported Fire Ant Project Agreement to the California Department of Food and Agriculture, 73-710 Fred Waring Drive, Suite 220, Palm Desert, CA 92260.

Should the Contractor be delayed, and such delay could not have been reasonably foreseen or prevented by the Contractor, the Contractor shall be entitled only to an equivalent extension of time for the completion of the Contract, and shall not be entitled to damages due to downtime and idled equipment or additional payments over and above the agreed upon unit prices.

Full compensation for compliance with the preceding requirements shall be considered as being included in the various Contract items in the bid schedule and no additional compensation will be allowed therefore, except if the RIFA are found. A Contract Change Order will be issued for the eradication of the RIFA.



## Report to City Council

---

**TO:**

**FROM:** Pat Jacquez-Nares, City Clerk

**AGENDA DATE:** January 15, 2019

**TITLE:** COUNCIL DISCRETIONARY EXPENDITURE REPORTS  
FOR FISCAL YEAR 2018/2019 AS OF JULY 1, 2018  
THROUGH NOVEMBER 30, 2018

---

### **RECOMMENDED ACTION**

**Recommendation:**

1. Receive and file the Fiscal Year 2018/2019 Council Discretionary Expenditure Report for July 1, 2018 through November 30, 2018.

### **SUMMARY**

This staff report is prepared at the request of the City Council to provide transparency with respect to the expenditure of City funds from City Council Discretionary Expenditure Accounts. These reports are for each Council Member's year to date expenditures for Fiscal Year 2018/2019, for July 1, 2018 through November 30, 2018. Each Council District receives an annual budget allocation of \$3,000 and the Mayor receives an annual budget allocation of \$6,000.

Unused monies from Fiscal Year 2017/2018 have been carried over to the current Fiscal Year as approved by City Council in Resolution 2018-78. The Discretionary Expenditure Reports now reflect amended budget amounts as approved in the aforementioned Resolution.

The expenditure reports are included routinely in the City Council agenda as an additional means of distributing reports on activities to the Council and public. The reports are to be posted to the City's website following Council approval. The monthly reports provide unaudited information and are reconciled to the City's general ledger. Following the end of the Fiscal Year, the financial information shall be reviewed as part of the City's independent financial audit.

**NOTIFICATION**

Posting of the agenda as required by the Brown Act.

**PREPARATION OF STAFF REPORT**

Prepared By:  
Renee Bryant  
Management Aide

Department Head Approval:  
Pat Jacquez-Nares  
City Clerk

**CITY COUNCIL GOALS**

None

**CITY COUNCIL STRATEGIC PRIORITIES**

- 1. Economic Development
- 2. Public Safety
- 3. Library
- 4. Infrastructure
- 5. Beautification, Community Engagement, and Quality of Life
- 6. Youth Programs

**ATTACHMENTS**

- 1. July - November Discretionary Reports

**APPROVALS**

|                         |                   |                 |
|-------------------------|-------------------|-----------------|
| Budget Officer Approval | <u>✓ Approved</u> | 1/10/19 8:57 AM |
| City Attorney Approval  | <u>✓ Approved</u> | 1/10/19 4:50 PM |
| City Manager Approval   | <u>✓ Approved</u> | 1/10/19 5:31 PM |





**MAYOR**

Fiscal Year 2018/2019 Council Discretionary Expenditures  
 Accounts: 1010-10-01-10015-620130 Mayor Discretionary  
 1010-10-01-10015-620131 Mayor Discretionary - Carryover  
 July 1, 2018 - November 30, 2018

| <b>Date</b> | <b>Amount</b> | <b>Description</b>                                    |
|-------------|---------------|---|
| 7/23/2018   | \$ 20.00      | LOCC Riverside County Division General Meeting        |
| 7/25/2018   | \$ 20.00      | MVCC Wake-Up Moreno Valley                            |
|             |               | No expenditures to report for August 2018             |
|             |               | No expenditures to report for September 2018          |
| 10/29/2018  | \$ 247.02     | Per Diem and Mileage - NLC Summit                     |
| 11/10/2018  | \$ 921.20     | Hotel Indigo Los Angeles Downtown: NLC Summit         |
| 11/30/2018  | \$ 30.00      | RCCD Fourth Annual Veterans Scholarship Breakfast     |
|             | \$ 1,238.22   | TOTAL Council Discretionary Expenditures for FY 18/19 |
|             | \$ 6,000.00   | FY 18/19 Adopted Budget Amount                        |
|             | \$ 5,589.00   | Carryover Budget Amount FY 2017/2018                  |
|             | \$ 11,589.00  | FY 18/19 Amended Budget Amount                        |
|             | \$ 10,350.78  | FY 18/19 Budget Amount Remaining                      |

Source: Unaudited financial data from the City's accounting records.  
 Updated as of: 01/07/2019



### COUNCIL DISTRICT 1

Fiscal Year 2018/2019 Council Discretionary Expenditures  
 Accounts: 1010-10-01-10011-620111 Council District 1 Discretionary  
 1010-10-01-10011-620116 Council District 1 Discretionary - Carryover  
 July 1, 2018 - November 30, 2018

| Date      | Amount      | Description   |
|-----------|-------------|---|
|           |             | No Expenditures to report for July 2018               |
|           |             | No Expenditures to report for August 2018             |
| 9/14/2018 | \$ 125.00   | Rotary Club of Moreno Valley 36th Annual Truck Party  |
| 10/2/2018 | \$ 150.00   | UNIDO Riverside Art Museum Cheech Marin               |
|           |             | No Expenditures to report for November 2018           |
|           | \$ 275.00   | TOTAL Council Discretionary Expenditures for FY 18/19 |
|           | \$ 3,000.00 | FY 18/19 Adopted Budget Amount                        |
|           | \$ 1,704.00 | Carryover Budget Amount FY 2017/2018                  |
|           | \$ 4,704.00 | FY 18/19 Amended Budget Amount                        |
|           | \$ 4,429.00 | FY 18/19 Budget Amount Remaining                      |

Source: Unaudited financial data from the City's accounting records.  
 Updated as of: 01/07/2019



**COUNCIL DISTRICT 2**

Fiscal Year 2018/2019 Council Discretionary Expenditures  
 Accounts: 1010-10-01-10012-620112 Council District 2 Discretionary  
 1010-10-01-10012-620117 Council District 2 Discretionary - Carryover  
 July 1, 2018 - November 30, 2018

| <b>Date</b> | <b>Amount</b> | <b>Description</b>  |
|-------------|---------------|---|
| 7/23/2018   | \$ 1,000.00   | Community Now's Annual Back 2 School Event<br>No expenditures to report for August 2018 |
| 9/13/2018   | \$ 147.00     | 2018 Inland Empire Economic Forecast  |
| 10/16/2018  | \$ 853.00     | Sponsorship Donation for Palm Middle School Autism Awareness                            |
| 10/29/2018  | \$ 500.00     | Sponsorship Donation for Friends of the Moreno Valley Senior Center                     |
| 11/14/2018  | \$ 50.00      | Greater Riverside Chamber of Commerce 19th Annual Raicross Trophy                       |
|             | \$ 2,550.00   | TOTAL Council Discretionary Expenditures for FY 18/19                                   |
|             | \$ 3,000.00   | FY 18/19 Adopted Budget Amount  |
|             | \$ 666.00     | Carryover Budget Amount FY 2017/2018  |
|             | \$ 3,666.00   | FY 18/19 Amended Budget Amount  |
|             | \$ 1,116.00   | FY 18/19 Budget Amount Remaining  |

Source: Unaudited financial data from the City's accounting records.  
 Updated as of: 01/07/2019



### COUNCIL DISTRICT 3

Fiscal Year 2018/2019 Council Discretionary Expenditures  
 Accounts: 1010-10-01-10013-620113 Council District 3 Discretionary  
 1010-10-01-10013-620118 Council District 3 Discretionary - Carryover  
 July 1, 2018 - November 30, 2018

| Date       | Amount      | Description   |
|------------|-------------|---|
| 7/19/2018  | \$ 85.00    | BIA Meet the Builder                                  |
| 7/23/2018  | \$ 20.00    | LOCC Riverside County Division General Meeting        |
| 7/24/2018  | \$ 500.00   | Community Now's Annual Back 2 School Event            |
| 8/23/2018  | \$ 50.00    | 2018 State of Riverside County                        |
| 9/17/2018  | \$ 55.00    | BIA Affordable Housing and Homelessness               |
| 9/19/2018  | \$ 45.00    | Economic and Workforce Development Summit             |
| 10/9/2018  | \$ 350.00   | Sponsorship Donation for Moreno Valley Community Band |
| 10/9/2018  | \$ 350.00   | Sponsorship Donation for Moreno Valley Master Chorale |
| 11/30/2018 | \$ 30.00    | RCCD Veterans Scholarship Breakfast                   |
|            | \$ 1,485.00 | TOTAL Council Discretionary Expenditures for FY 18/19 |
|            | \$ 3,000.00 | FY 18/19 Adopted Budget Amount                        |
|            | \$ 1,024.00 | Carryover Budget Amount FY 2017/2018                  |
|            | \$ 4,024.00 | FY 18/19 Amended Budget Amount                        |
|            | \$ 2,539.00 | FY 18/19 Budget Amount Remaining                      |

Source: Unaudited financial data from the City's accounting records.

Updated as of: 01/07/2019



#### COUNCIL DISTRICT 4

Fiscal Year 2018/2019 Council Discretionary Expenditures  
 Accounts: 1010-10-01-10014-620114 Council District 4 Discretionary  
 1010-10-01-10014-650119 Council District 4 Discretionary - Carryover  
 July 1, 2018 - November 30, 2018

| Date      | Amount      | Description   |
|-----------|-------------|---|
| 7/19/2018 | \$ 85.00    | BIA Meet the Builder  |
| 7/26/2018 | \$ (350.00) | Refund for cancellation - YEO Conference (originally charged in FY 17/18)<br>No Expenditures to report for August 2018                      |
| 9/12/2018 | \$ 150.00   | 12th Annual San Bernardino County Water Conference  |
| 9/12/2018 | \$ 40.00    | Let's Do Lunch-Annual Conference Lunch Meeting<br>No Expenditures to report for October 2018<br>No Expenditures to report for November 2018 |
|           | \$ (75.00)  | TOTAL Council Discretionary Expenditures for FY 18/19   |
|           | \$ 3,000.00 | FY 18/19 Adopted Budget Amount  |
|           | \$ 244.00   | Carryover Budget Amount FY 2017/2018  |
|           | \$ 3,244.00 | FY 18/19 Amended Budget Amount  |
|           | \$ 3,319.00 | FY 18/19 Budget Amount Remaining  |

Source: Unaudited financial data from the City's accounting records.  
 Updated as of: 01/07/2019



## Report to City Council

---

**TO:** Mayor and City Council

**FROM:** Pat Jacquez-Nares, City Clerk

**AGENDA DATE:** January 15, 2019

**TITLE:** 2019 CITY COUNCIL COMMISSION, BOARD, AND TASKFORCE PARTICIPATION APPOINTMENTS

---

### **RECOMMENDED ACTION**

#### **Recommendations: That the City Council:**

1. Ratify as one slate the Mayor's appointments to the various committees as noted on the 2019 Council Committee Participation List.

### **SUMMARY**

The previous Council Committee Participation appointments expired on December 31, 2018. Mayor Gutierrez has compiled the new 2019 Council Committee Participation List of appointments to the various committees with the terms as follows:

| <b><i>CITY COUNCIL ADVISORY COMMISSIONS/ BOARDS:</i></b> | <b><i>Primary</i></b> | <b><i>Alternate</i></b> | <b><i>Term</i></b> |
|--|-----------------------|-------------------------|--------------------|
| Arts Commission  | Baca                  | Marquez                 | 6/30/2019          |
| Emerging Leaders Council                                 | Cabrera               | Gutierrez               | 6/30/2019          |
| Environmental and Historical Preservation Board          | Marquez               | n/a                     | 6/30/2019          |
| Library Commission                                       | Baca                  | Gutierrez               | 6/30/2019          |
| Parks, Community Services and Trails Committee           | Gutierrez             | Thornton                | 6/30/2019          |
| Senior Citizens' Advisory Board                          | Baca                  | Thornton                | 6/30/2019          |
| Traffic Safety Commission                                | Thornton              | Cabrera                 | 6/30/2019          |
| Utilities Commission                                     | Cabrera               | Baca                    | 6/30/2019          |

| <b>CITY COUNCIL SUBCOMMITTEES:</b> |                   |           | <b>Primary</b> | <b>Alternate</b>         | <b>Term</b> |
|------------------------------------|-------------------|-----------|----------------|--------------------------|-------------|
| Economic Development Subcommittee  | Baca/Gutierrez    | Marquez   | 6/30/2019      | <i>Appoint 2 Primary</i> |             |
| Finance Subcommittee               | Cabrera/Gutierrez | Thornton  | 6/30/2019      | <i>Appoint 2 Primary</i> |             |
| Public Safety Subcommittee         | Thornton/Baca     | Gutierrez | 6/30/2019      | <i>Appoint 2 Primary</i> |             |

| <b>INTER-AGENCY:</b>   |               |           | <b>Primary</b> | <b>Alternate</b>         | <b>Term</b> |
|--|---------------|-----------|----------------|--------------------------|-------------|
| March Joint Powers Commission (JPC)                            | Baca/Thornton | Cabrera   | 12/31/2019     | <i>Appoint 2 Primary</i> |             |
| School Districts/City Joint Task Force                         | Baca/Cabrera  | Gutierrez | 12/31/2019     | <i>Appoint 2 Primary</i> |             |
| Riverside County Habitat Conservation Agency (RCHCA)           | Marquez       | n/a       | 12/31/2019     |                          |             |
| Riverside County Transportation Commission (RCTC)              | Thornton      | Gutierrez | 12/31/2019     |                          |             |
| Riverside Transit Agency (RTA)                                 | Cabrera       | Gutierrez | 12/31/2019     |                          |             |
| Western Riverside Council of Governments (WRCOG)               | Baca          | Gutierrez | 12/31/2019     |                          |             |
| Western Riverside County Regional Conservation Authority (RCA) | Marquez       | n/a       | 12/31/2019     |                          |             |

**PREPARATION OF STAFF REPORT**

Prepared By:  
Pat Jacquez-Nares  
City Clerk

Department Head Approval:  
Pat Jacquez-Nares  
City Clerk

**CITY COUNCIL GOALS**

**Advocacy.** Develop cooperative intergovernmental relationships and be a forceful advocate of City policies, objectives, and goals to appropriate external governments, agencies and corporations.

**CITY COUNCIL STRATEGIC PRIORITIES**

1. Economic Development
2. Public Safety
3. Library
4. Infrastructure
5. Beautification, Community Engagement, and Quality of Life
6. Youth Programs

**ATTACHMENTS**

None

**APPROVALS**

|                         |                   |                 |
|-------------------------|-------------------|-----------------|
| Budget Officer Approval | <u>✓ Approved</u> | 1/10/19 8:58 AM |
| City Attorney Approval  | <u>✓ Approved</u> | 1/10/19 4:49 PM |
| City Manager Approval   | <u>✓ Approved</u> | 1/10/19 5:30 PM |





## Report to City Council

---

**TO:** Mayor and City Council Acting in its Capacity as President and Members of the Board of Directors of the Moreno Valley Community Services District (CSD)

**FROM:** Michael L. Wolfe, P.E., Public Works Director/City Engineer

**AGENDA DATE:** January 15, 2019

**TITLE:** APPROVE THE FIRST AMENDMENT TO THE ON-SITE AND/OR PROFESSIONAL SERVICES AGREEMENT (CONTRACT NO. CSD 2018-50) FOR LANDSCAPE MAINTENANCE SERVICES (LANDSCAPE MAINTENANCE - ZONE 02)

---

### **RECOMMENDED ACTION**

#### **Recommendations:**

1. Approve the First Amendment to the On-Site and/or Professional Services Agreement (Contract No. CSD 2018-50) for Landscape Maintenance – Zone 02, Maintenance of Parkway, Median, and Open Space Landscaping and Irrigation (“Agreement”) with Mariposa Landscapes, Inc., 6232 Santos Diaz St., Irwindale, CA 91702, to provide landscape and irrigation maintenance services for Zone 02 of Landscape Maintenance District (LMD) No. 2014-02 for a total contract amount Not-To-Exceed (NTE) \$1,619,200.
2. Approve the budget adjustment as set forth in the Fiscal Impact section of this report.
3. Authorize the Public Works Director/City Engineer to execute the First Amendment, in substantially the form as attached hereto, subject to the approval of the City Attorney.

### **SUMMARY**

This report recommends approval of the First Amendment to the Agreement to provide maintenance of parkway, median, and open space landscaping and irrigation with Mariposa Landscapes, Inc. The First Amendment increases the NTE amount of the Agreement by \$285,000, which will allow for the provision of additional work services benefiting Zone 02 of LMD No. 2014-02.

Funding for the landscape and irrigation maintenance services is provided through a special assessment collected as part of the annual property tax bill. The special assessment is only applied to those properties receiving special benefit from the public landscaping. Revenue received from the special assessment is restricted and can only be used for landscape maintenance services in Zone 02 of the LMD.

## **DISCUSSION**

On June 19, 2018, the CSD Board awarded a multi-year Agreement for landscape and irrigation maintenance services for Zone 02 of LMD No. 2014-02 for a NTE amount of \$1,334,200, authorized the City Manager to execute the Agreement, and authorized the Public Works Director/City Engineer to execute subsequent amendments to the Agreement, provided sufficient funding appropriations and program approvals have been granted by the City Council. The Agreement has a five-year term, through June 30, 2023.

The Agreement allows for the provision of routine maintenance of the public landscaping and irrigation (Base Work) and additional work services (e.g., reinvestments for irrigation repairs, replants, and other related landscape work). Property owners within Zone 02 of the LMD pay a special assessment as part of their annual property tax bill. Revenue received from the special assessment funds the cost to provide the landscape maintenance services. The funds received are restricted and can only be used for landscape maintenance services in Zone 02 of the LMD.

The First Amendment, attached hereto, increases the NTE amount to \$1,619,200, an increase of \$285,000 to allow for completion of newly identified reinvestment projects within Zone 02. The reinvestment projects will be funded through the use of one-time monies available from Zone 02's unassigned reserves. The retrofit of the landscaping and irrigation in the parkway (i.e., between the sidewalk and curb) on the west side of Pigeon Pass Road from Hidden Springs Parkway to Old Lake Drive is scheduled to occur during FY 2018/19 and an upgrade to radio equipment for the centralized irrigation system and replacement of fencing is planned for FY 2019/20.

This action meets the Strategic Plan Priorities to manage and maximize Moreno Valley's public infrastructure to ensure an excellent quality of life, develop and implement innovative, cost effective infrastructure maintenance programs, public facilities management strategies, and capital improvement programming and project delivery.

## **ALTERNATIVES**

1. Approve the First Amendment to the Agreement for landscape and irrigation maintenance services with Mariposa Landscapes, Inc. and related recommended actions as presented in this staff report. *Staff recommends this alternative to provide additional work services of the public landscaping in Zone 02.*
2. Do not approve the First Amendment. *Staff does not recommend this alternative as it will not allow for the provision of additional work services in the public landscaping in Zone 02.*
3. Do not approve the First Amendment, but continue the item to a future City Council meeting. *Staff does not recommend this alternative as it will delay the additional work services in the public landscaping in Zone 02.*

## **FISCAL IMPACT**

Administration and maintenance costs to provide public landscape maintenance services in Zone 02 is funded through a property owner approved special assessment, which is levied on the annual property tax bills. Revenue from the special assessment can only be used for landscape maintenance services and administrative costs associated with the public landscaping in Zone 02.

Funding for the increase in additional work services for FY 2018/19 was not included in the adopted budget and requires a budget adjustment. The proposed amendment to the budget is detailed below. Budget appropriations for FY 2019/20 will be included as part of the proposed FY 2019/20 budget process. With these additional expenditures, Zone 02 will still have adequate reserve levels.

| Description | Fund            | GL Account No.<br>Project                               | Type<br>(Rev/Exp) | FY 2018/19 |           |                   |
|-------------|-----------------|---|-------------------|------------|-----------|-------------------|
|             |                 |   |                   | Budget     | Amendment | Amended<br>Budget |
| Amendment   | LMD No. 2014-02 | 5014-70-79-25721-620910 <sup>1</sup><br>SD LMD ZN 02-HS | Exp.              | \$274,200  | \$165,000 | \$439,200         |

<sup>1</sup>The FY 2018/19 budget for 5014-70-79-25721-620910 is \$1,286,600, which includes all special benefit zones within LMD No. 2014-02. The proposed amendment will increase the budget for this account to \$1,451,600.

The total value of the Agreement, including the First Amendment, is detailed below.

| Landscape Maintenance - Zone 02 |                                    |                                   |                      |                      |                      |                 |
|---------------------------------|------------------------------------|-----------------------------------|----------------------|----------------------|----------------------|-----------------|
|                                 | Original Agreement & 1st Amendment | Projections <sup>6</sup>          |                      |                      |                      |                 |
|                                 | FY 2018/19<br>Year 1 <sup>4</sup>  | FY 2019/20<br>Year 2 <sup>5</sup> | FY 2020/21<br>Year 3 | FY 2021/22<br>Year 4 | FY 2022/23<br>Year 5 | Total           |
| Base Work <sup>1</sup>          | \$ 113,136.00                      | \$ 125,600.00                     | \$ 131,900.00        | \$ 138,500.00        | \$ 145,500.00        | \$ 654,636.00   |
| Additional Work <sup>2,3</sup>  | \$ 287,864.00                      | \$ 249,100.00                     | \$ 135,600.00        | \$ 142,400.00        | \$ 149,600.00        | \$ 964,564.00   |
| Total                           | \$ 401,000.00                      | \$ 374,700.00                     | \$ 267,500.00        | \$ 280,900.00        | \$ 295,100.00        | \$ 1,619,200.00 |

<sup>1</sup>Base Work is for routine landscape and irrigation maintenance.  
<sup>2</sup>Additional Work is for reinvestments (e.g. replants), unanticipated/emergency repairs, parts and labor.  
<sup>3</sup>Additional Work amounts are estimated and may fluctuate in any given year based on the area's ability to support the services and City Council approval of appropriate funding levels. Pricing is based on pricing terms of the Agreement (Exhibit E, Schedule II).  
<sup>4</sup>Increase in Additional Work services to include retrofit to parkway irrigation and landscaping (between sidewalk and curb) on Pigeon Pass Road between Hidden Springs Parkway and Old Lake Road.  
<sup>5</sup>Increase in Additional Work services to upgrade the centralized irrigation system's radio frequencies and repairs to fencing  
<sup>6</sup>Amounts listed for subsequent years in the Agreement are estimated based on information known at the present time. Actual amounts may vary depending on the addition/removal of service areas, an area's financial resources, and City Council program and budget approvals. The purchase order will be based on actual amounts authorized.

**NOTIFICATION**

Posting of the Agenda.

**PREPARATION OF STAFF REPORT**

Prepared By:  
 Candace E. Cassel  
 Special Districts Division Manager

Department Head Approval:  
 Michael L. Wolfe, P. E.  
 Public Works Director/City Engineer

**CITY COUNCIL GOALS**

**Positive Environment.** Create a positive environment for the development of Moreno Valley's future.

**Community Image, Neighborhood Pride and Cleanliness.** Promote a sense of community pride and foster an excellent image about our City by developing and executing programs which will result in quality development, enhanced neighborhood preservation efforts, including home rehabilitation and neighborhood restoration.

**CITY COUNCIL STRATEGIC PRIORITIES**

1. Economic Development
2. Public Safety
3. Library
4. Infrastructure
5. Beautification, Community Engagement, and Quality of Life

## 6. Youth Programs

See the Discussion section above for details of how this action supports the City Council's Strategic Priorities.

### ATTACHMENTS

1. First Amendment to Agreement
2. Agreement for On-Site and/or Professional Services

### APPROVALS

|                         |                   |                  |
|-------------------------|-------------------|------------------|
| Budget Officer Approval | <u>✓ Approved</u> | 1/07/19 10:08 AM |
| City Attorney Approval  | <u>✓ Approved</u> | 1/03/19 3:40 PM  |
| City Manager Approval   | <u>✓ Approved</u> | 1/08/19 3:35 PM  |

**FIRST AMENDMENT TO AGREEMENT  
FOR LANDSCAPE AND IRRIGATION MAINTENANCE  
PROJECT NO. 2018-014**

The First Amendment to Agreement is by and between the CITY OF MORENO VALLEY, a municipal corporation, hereinafter referred to as “City,” and MARIPOSA LANDSCAPES, INC., a Corporation, hereinafter referred to as “Consultant.” This First Amendment to Agreement is made and entered into effective on the date the City signs this Amendment.

RECITALS:

Whereas, the City and Consultant entered into an Agreement entitled “Agreement For On-Site And/Or Professional Services,” hereinafter referred to as “Agreement,” dated June 27, 2018.

Whereas, the Consultant is providing landscape and irrigation maintenance services.

Whereas, it is desirable to amend the Agreement to expand the scope of the work to be performed by the Consultant for fiscal year 2018/19 as is more particularly described in Section 1 of this First Amendment and as identified in the Consultant’s Proposal dated October 25, 2018, a copy of which is attached as “Exhibit A - First Amendment” and is incorporated herein by this reference.

Whereas, it is desirable to amend the not-to-exceed amount of the Agreement to allow for additional services to be provided during the term of the Agreement.

Whereas, it is desirable to correct a typographical error wherein the monthly and annual compensation amounts for routine Base Work services are incorrect.

SECTION 1 AMENDMENT TO ORIGINAL AGREEMENT:

1.1 The Agreement is hereby amended by adding to the fiscal year 2018/19 scope of work for the retrofit of the Pigeon Pass parkway area as described in “Exhibit A – First Amendment,” entitled “Pigeon Pass Road Parkway Area.”

FIRST AMENDMENT TO AGREEMENT FOR LANDSCAPE MAINTENANCE – ZONE 02  
PROJECT NO. 2018-014

1.3 Section 1.A of Exhibit “C” to the Agreement is hereby amended to read as follows:

“The Contractor’s compensation shall not exceed \$1,619,200.”

1.4 Section 1.B of Exhibit “C” to the Agreement is hereby amended to read as follows:

“Except where additional compensation is specifically provided for in this Agreement, the City will pay the Contractor for all work (labor, material, supplies, equipment, etc.) performed under this Agreement for fiscal year 2018/19 the total amount of Nine Thousand, Four Hundred Twenty-Eight and 00/100 Dollars (\$9,428.00) per month, one (1) month in arrears, on the last day of the month. The total Agreement amount for twelve (12) months shall not exceed One Hundred Thirteen, One Hundred Thirty-Six and 00/100 Dollars (\$113,136.00), except as provided for herein Exhibit C, Section 2 below.”

1.5 Section 2.G of Exhibit “C” to the Agreement is hereby amended to read as follows:

“Except as specifically approved by subsequent action of the City Council and/or District Board of Directors, the Director may not authorize Additional Work in excess of Two Hundred Eighty-Seven, Eight Hundred Sixty-Four and 00/100 (\$287,864.00) for fiscal year 2018/19.”

1.6 The table in Section 5 of Exhibit “C” to the Agreement is hereby replaced with the table below:

FIRST AMENDMENT TO AGREEMENT FOR LANDSCAPE MAINTENANCE – ZONE 02  
PROJECT NO. 2018-014

| FY 2018/19 Landscape Maintenance Service Schedule |                              |                        |                  |                    |                      |                                |                      |
|---|------------------------------|------------------------|------------------|--------------------|----------------------|--------------------------------|----------------------|
| GL Account  | Service Area                 | Base Work <sup>1</sup> |                  |                    |                      | Additional Work <sup>2,3</sup> | Total                |
|   |                              | Service Level          | Est. Sq Ft.      | Monthly Cost       | Annual Cost          |                                |                      |
| 5014-70-79-25721-620910<br>SD LMD ZN 02-HS        | Zone 02 Parkways &<br>Median | Level 1                | 265,280          | \$ 5,508.00        | \$ 66,096.00         | \$ 287,864.00                  | \$ 401,000.00        |
| 5014-70-79-25721-620910<br>SD LMD ZN 02-HS        |                              | Level 1                | 3,308,892        | \$ 3,920.00        | \$ 47,040.00         |                                |                      |
| <b>Subtotal</b>                                   |                              |                        | <b>3,574,172</b> | <b>\$ 9,428.00</b> | <b>\$ 113,136.00</b> | <b>\$ 287,864.00</b>           | <b>\$ 401,000.00</b> |

<sup>1</sup> Base Work is routine maintenance at a regular frequency (i.e. service level). Parkway & Median - Level 1 = 4 week rotation; Level 2 = 8 week rotation; Level 3 = 12 week rotation. See Exhibit E, Schedule II - Frequency of Services Table for additional information.  
Paseos - Divided into 6 maintenance areas. Each area receives shrub trimming, trail and fence clearing, and clearance of a 24' width of open space abutting residential parcels.  
Level 1 = Monthly (1 maintenance area per month, 6 month rotation) + 1 annual weed abatement  
Level 2 = Every Other Month (1 maintenance area every other month, 12 month rotation) + 1 annual weed abatement  
Level 3 = Quarterly (1 maintenance area every quarter, 18 month rotation) + 1 annual weed abatement  
Level 4 = Annually (annual clearance of 24' width only, no shrub trimming or trail/fence clearing)  
<sup>2</sup> Additional Work is for unanticipated/emergency work and reinvestments. The amounts are based on an area's financial resources to support work beyond routine maintenance, may vary in any given year and are contingent upon budget approvals.  
<sup>3</sup> 1st Amendment increases additional work services to retrofit landscape and irrigation in parkway on Pigeon Pass.

**SECTION 2**

2.1 Except as otherwise specifically provided in this Amendment, all other terms and conditions of the Agreement shall remain in full force and effect.

**SIGNATURE PAGE TO FOLLOW**



FIRST AMENDMENT TO AGREEMENT FOR LANDSCAPE MAINTENANCE – ZONE 02  
PROJECT NO. 2018-014

IN WITNESS HEREOF, the parties have each caused their authorized representative to execute this Agreement.

City of Moreno Valley

Mariposa Landscapes, Inc.

By: \_\_\_\_\_  
(SIGNATURE)

By: \_\_\_\_\_  
(SIGNATURE)

\_\_\_\_\_  
(PRINTED)

\_\_\_\_\_  
(PRINTED)

Title: Public Works Director/City Engineer

Title: (President or Vice President)

Date: \_\_\_\_\_

Date: \_\_\_\_\_

|   |
|---|
| <p><b><u>INTERNAL USE ONLY</u></b></p> <p><b><u>APPROVED AS TO LEGAL FORM:</u></b></p><br><p>_____</p> <p style="text-align: center;">City Attorney</p><br><p>_____</p> <p style="text-align: center;">Date</p> |
|---|

By: \_\_\_\_\_  
Title: Corporate Secretary or Assistant Secretary

Date: \_\_\_\_\_

Affix Corporate Seal Below

Attachments: Exhibit A – First Amendment

Attachment: First Amendment to Agreement (3332 : APPROVE THE FIRST AMENDMENT TO THE ON-SITE AND/OR PROFESSIONAL SERVICES

Exhibit A – First Amendment  
Pigeon Pass Road Parkway Area



PROPOSAL

October 25, 2018  
City of Moreno Valley  
14177 Frederick Street  
Moreno Valley, California 92553  
Attn: Danny Cover / [dannyc@moval.org](mailto:dannyc@moval.org)

**Re:** Removal and disposal of 3" of vegetation and soil at Parkway area adjacent to Pigeon Pass Road. Removal and disposal of vegetation at planting area next to the residential CMU wall. Cut and remove irrigation heads. Add filter and pressure regulators to existing remote control valves to convert irrigation to Drip. Install 2,365 (5 Gallon) miscellaneous shrub material at Parkway planting area and 3,500 (5 Gallon) miscellaneous shrub material at areas adjacent to the CMU wall. Furnish and install 100 CY of Cover mulch after planting at Parkway area and 250 CY of Cover mulch at area next to the CMU wall.

**Description:** This proposal provides for all labor, material, and equipment to perform the installation of irrigation, Shrub material, Cover mulch at the above site located at:  
**Pigeon Pass Road (between Old Lake to Hidden Springs Dr. – Moreno Valley, CA State Prevailing Wage. Inclusions and Exclusions on next page.**

|                      |       |                      |
|----------------------|-------|----------------------|
| <b>Parkway Area</b>  | ..... | <b>\$ 164,009.00</b> |
| <b>CMU Wall Area</b> | ..... | <b>\$ 211,833.00</b> |

Wall Area - Not included in FY 2018/19 Scope of Work

**Terms:** Per agreed Schedule of Values.

**Exclusions:** Lighting fixtures. Site Fixtures, Concrete Paving, Concrete Saw Cutting. Water Proofing. No hazardous waste removal. Extra work due to any unforeseen obstacles underground not included. No cleanup of debris left by other trades. Permits.

**Time:** Project start date is within 30-40 days after notice to proceed. Completion time for this project will depends of the duration of each of four phases.

**Limits:** Time limit for the acceptance of this proposal is 30 calendar days from the above mentioned date.

Respectfully submitted,

Marvin Zamora – Estimator  
[marvin.zamora@mariposa-ca.com](mailto:marvin.zamora@mariposa-ca.com)



CA CONTRACTOR'S LIC # 592268 A, C-27, D-49  
6232 Santos Diaz St., Irwindale, CA 91702 • TEL 800•794•9458 • FAX 626•960•8477  
[www.mariposa-ca.com](http://www.mariposa-ca.com)

Attachment: First Amendment to Agreement (3332 : APPROVE THE FIRST AMENDMENT TO THE ON-SITE AND/OR PROFESSIONAL SERVICES

## Exhibit A – First Amendment Pigeon Pass Road Parkways

### Including:

1. Removal and Disposal of Vegetation at Parkway and CMU Wall Areas
2. Removal and Disposal of 3" of Soil at Parkway Area only
3. Removal and Disposal of Existing Irrigation Heads
4. Furnish and Install of Pressure Regulator and Filter to each valve for Drip conversion
5. Furnish and Install Netafim Dripline Tubing
6. Furnish and Install of Air Relief Valves for Dripline System
7. Furnish and Install of Flush Valves for Dripline System
8. Furnish and Install 5 Gallon Material per quantities on proposal request
9. Furnish and Install Cover Mulch per quantities per quantities on proposal request

### Exclusions:

1. Site Furnishing
2. Lighting Fixtures
3. Concrete/Asphalt Sawcut
4. No Boring thru planter or Slabs
5. New Concrete Paving
6. Backflow
7. Irrigation Controller
8. Electrical for Controllers
9. Permits
10. Maintenance
11. Bond Cost



CA CONTRACTOR'S LIC # 592268 A, C-27, D-49  
6232 Santos Diaz St., Irwindale, CA 91702 • TEL 800•794•9458 • FAX 626•960•8477  
[www.mariposa-ca.com](http://www.mariposa-ca.com)

Page 2 of 2

City of Moreno Valley

**AGREEMENT FOR ON-SITE AND/OR PROFESSIONAL SERVICES**

This Agreement is made by and between the City of Moreno Valley and Moreno Valley Moreno Valley Community Services District, California, a municipal corporation, with its principal place of business at 14177 Frederick Street, Moreno Valley, CA 92553, hereinafter referred to as the "City", and Mariposa Landscapes, Inc., a Corporation, with its principal place of business at 6232 Santos Diaz St., Irwindale, CA 91702, hereinafter referred to as the "Contractor," based upon City policies and the following legal citations:

**RECITALS**

- A. Government Code Section 53060 authorizes the engagement of persons to perform special services as independent contractors;
- B. Contractor desires to perform and assume responsibility for the provision of professional landscape and irrigation maintenance contracting services required by the City on the terms and conditions set forth in this Agreement. Contractor represents that it is experienced in providing professional landscape and irrigation maintenance contracting services, is licensed in the State of California, if applicable;
- C. City desires to engage Contractor to render such services for the landscape and irrigation maintenance as set forth in this Agreement;
- D. The public interest, convenience, necessity and general welfare will be served by this Agreement; and
- E. This Agreement is made and entered into effective the date the City signs this Agreement.

**TERMS**

**1. CONTRACTOR INFORMATION:**

|                          |                           |
|--------------------------|---------------------------|
| Contractor's Name:       | Mariposa Landscapes, Inc. |
| Address:                 | 6232 Santos Diaz St.      |
| City, State, Zip:        | Irwindale, CA 91702       |
| Business Phone:          | 626-960-0196              |
| Business License Number: | 16607                     |
| Federal Tax I.D. Number: | 95-4245898                |

**2. CONTRACTOR SERVICES, FEES, AND RELEVANT DATES:**

- A. The Contractor's scope of service is described in Exhibit "A" attached hereto and incorporated herein by this reference.
- B. The City's responsibilities, other than payment, are described in Exhibit "B" attached hereto and incorporated herein by this reference.
- C. Payment terms are provided in Exhibit "C" attached hereto and incorporated herein by this reference.

- D. The term of this Agreement shall be from July 1, 2018 to June 30, 2023 and as provided in Exhibit “D” attached hereto and incorporated herein by this reference, unless terminated earlier as provided herein. The City acknowledges that it will not unreasonably withhold approval of the Contractor’s requests for extensions of time in which to complete the work required. The Contractor shall not be responsible for performance delays caused by others or delays beyond the Contractor’s reasonable control (excluding delays caused by non-performance or unjustified delay by Contractor, his/her/its employees, or subcontractors), and such delays shall extend the time for performance of the work by the Contractor.
- E. The Contractor’s Proposal is provided in Exhibit “E” attached hereto and incorporated herein by this reference.

3. **STANDARD TERMS AND CONDITIONS:**

- A. Control of Work. Contractor is solely responsible for the content and sequence of the work, and will not be subject to control and direction as to the details and means for accomplishing the anticipated results of services. The City will not provide any training to Contractor or his/her/its employees.
- B. Intent of Parties. Contractor is, and at all times shall be, an independent contractor and nothing contained herein shall be construed as making the Contractor or any individual whose compensation for services is paid by the Contractor, an agent or employee of the City, or authorizing the Contractor to create or assume any obligation or liability for or on behalf of the City, or entitling the Contractor to any right, benefit, or privilege applicable to any officer or employee of the City.
- C. Subcontracting. Contractor may retain or subcontract for the services of other necessary contractors with the prior written approval of the City. Payment for such services shall be the responsibility of the Contractor. Any and all subcontractors shall be subject to the terms and conditions of this Agreement, with the exception that the City shall have no obligation to pay for any subcontractor services rendered. Contractor shall be responsible for paying prevailing wages where required by law [See California Labor Code Sections 1770 through 1777.7].
- D. Conformance to Applicable Requirements. All work prepared by Contractor shall be subject to the approval of City.
- E. Substitution of Key Personnel. Contractor has represented to City that certain key personnel will perform and coordinate the services under this Agreement. Should one or more of such personnel become unavailable, Contractor may substitute other personnel of at least equal competence upon written approval of City. In the event that City and Contractor cannot agree as to the substitution of key personnel, City shall be entitled to terminate this Agreement for cause. As discussed below, any personnel who fail or refuse to perform the services in a manner acceptable to the City, or who are determined by the City to be uncooperative, incompetent, a threat to the adequate or timely completion of the project or a threat to the safety of

persons or property, shall be promptly removed from the project by the Contractor at the request of the City. The key personnel for performance of this Agreement are as follows: Terry Noriega.

- F. City's Representative. The City hereby designates the City Manager, or his or her designee, to act as its representative for the performance of this Agreement ("City's Representative"). Contractor shall not accept direction or orders from any person other than the City's Representative or his or her designee.
- G. Contractor's Representative. Contractor hereby designates Terry Noriega, or his or her designee, to act as its representative for the performance of this Agreement ("Contractor's Representative"). Contractor's Representative shall have full authority to represent and act on behalf of the Contractor for all purposes under this Agreement. The Contractor's Representative shall supervise and direct the services, using his or her best skill and attention, and shall be responsible for all means, methods, techniques, sequences and procedures and for the satisfactory coordination of all portions of the services under this Agreement.
- H. Legal Considerations. The Contractor shall comply with applicable federal, state, and local laws in the performance of this Agreement. Contractor shall be liable for all violations of such laws and regulations in connection with services. If the Contractor performs any work knowing it to be contrary to such laws, rules and regulations and without giving written notice to the City, Contractor shall be solely responsible for all costs arising therefrom. Contractor shall defend, indemnify and hold City, its officials, directors, officers, employees and agents free and harmless, pursuant to the indemnification provisions of this Agreement, from any claim or liability arising out of any failure or alleged failure to comply with such laws, rules or regulations.
- I. Standard of Care; Performance of Employees. Contractor shall perform all services under this Agreement in a skillful and competent manner, consistent with the standards generally recognized as being employed by professionals in the same discipline in the State of California. Contractor represents and maintains that it is skilled in the profession necessary to perform the services. Contractor warrants that all employees and subcontractor shall have sufficient skill and experience to perform the services assigned to them. Finally, Contractor represents that it, its employees and subcontractors have all licenses, permits, qualifications and approvals of whatever nature that are legally required to perform the services and that such licenses and approvals shall be maintained throughout the term of this Agreement. Any employee of the Contractor or its subcontractors who is determined by the City to be uncooperative, incompetent, a threat to the adequate or timely completion of the project, a threat to the safety of persons or property, or any employee who fails or refuses to perform the services in a manner acceptable to the City, shall be promptly removed from the project by the Contractor and shall not be re-employed to perform any of the services or to work on the project.

- J. Contractor Indemnification. Contractor shall indemnify, defend and hold the City, the Moreno Valley Housing Authority, and the Moreno Valley Community Services District (CSD), their officers, agents and employees harmless from any and all claims, damages, losses, causes of action and demands, including, without limitation, the payment of all consequential damages, expert witness fees, reasonable attorney's fees and other related costs and expenses, incurred in connection with or in any manner arising out of Contractor's performance of the work contemplated by this Agreement and this Agreement. Acceptance of this Agreement signifies that the Contractor is not covered under the City's general liability insurance, employee benefits, or worker's compensation. It further establishes that the Contractor shall be fully responsible for such coverage. Contractor's obligation to indemnify shall survive expiration or termination of this Agreement, and shall not be restricted to insurance proceeds, if any, received by the City, the Moreno Valley Housing Authority, and the CSD, and their officers, agents and employees.
- K. Additional Indemnity Obligations. Contractor shall defend, with counsel of City's choosing and at Contractor's own cost, expense and risk, any and all claims, suits, actions or other proceedings of every kind covered by Section "J" that may be brought or instituted against City, the Moreno Valley Housing Authority, and the CSD, and their officers, agents and employees. Contractor shall pay and satisfy any judgment, award or decree that may be rendered against City, the Moreno Valley Housing Authority, and the CSD, and their officers, agents and employees as part of any such claim, suit, action or other proceeding. Contractor shall also reimburse City for the cost of any settlement paid by City, the Moreno Valley Housing Authority, and the CSD, and their officers, agents and employees as part of any such claim, suit, action or other proceeding. Such reimbursement shall include payment for City's attorney's fees and costs, including expert witness fees. Contractor shall reimburse City, the Moreno Valley Housing Authority, and the CSD, and their officers, agents and employees for any and all legal expenses and costs incurred by each of them in connection therewith or in enforcing the indemnity herein provided.
- L. Insurance Requirements. The Contractor will comply with the following insurance requirements at its sole expense. Insurance companies shall be rated (A Minus: VII—Admitted) or better in Best's Insurance Rating Guide and shall be legally licensed and qualified to conduct business in the State of California:

The Contractor shall procure and maintain, at its sole expense, Workers' Compensation Insurance in such amounts as will fully comply with the laws of the State of California and which shall indemnify, insure and provide legal defense for the Contractor and the City, the Housing Authority and CSD against any loss, claim, or damage arising from any injuries or occupational diseases happening to any worker employed by the Contractor in the course of carrying out the Agreement. This coverage may be waived if the Contractor is determined to be functioning as a sole proprietor and the city provided form

“Exception to Worker’s Compensation Coverage” is signed, notarized and attached to this Agreement

X General Liability Insurance—to protect against loss from liability imposed by law for damages on account of bodily injury, including death, and/or property damage suffered or alleged to be suffered by any person or persons whomever, resulting directly or indirectly from any act or activities of the Contractor, sub-Contractor, or any person acting for the Contractor or under its control or direction. Such insurance shall be maintained in full force and effect throughout the terms of the Agreement and any extension thereof in the minimum amounts provided below:

|                 |   |
|-----------------|---|
| Bodily Injury   | \$1,000,000 per occurrence/ \$2,000,000 aggregate |
| Property Damage | \$500,000 per occurrence/ \$500,000 aggregate     |

Professional Errors and Omission Insurance—such coverage shall not be less than \$1,000,000 per claim and aggregate.

X Liability and Property Damage Insurance coverage for owned and non-owned automotive equipment operated on City/CSD/Housing Authority premises. Such coverage limits shall not be less than \$1,000,000 combined single limit.

X A Certificate of Insurance and appropriate additional insured endorsement evidencing the above applicable insurance coverage shall be submitted to the City prior to the execution of this Agreement. The Certificate of Insurance or an appropriate binder shall bear an endorsement containing the following provisions:

Solely as respect to services done by or on behalf of the named insured for the City of Moreno Valley, it is agreed that the City of Moreno Valley, the Moreno Valley Housing Authority, and the Moreno Valley Community Services District, their officers, employees and agents are included as additional insured under this policy and the coverage(s) provided shall be primary insurance and not contributing with any other insurance available to the City of Moreno Valley, the Moreno Valley Housing Authority, and the Moreno Valley Community Services District, its officers, employees and agents, under any third party liability policy

The terms of the insurance policy or policies issued to provide the above coverage shall neither be amended to reduce the required insurance limits and coverages nor shall such policies be canceled by the carrier without thirty (30) days prior written notice by certified or registered mail of amendment or cancellation to the City, except that cancellation for non-payment of premium shall require ten (10) days prior written notice by certified or registered mail. In the event the insurance is canceled, the Contractor shall, prior to the

Attachment: Agreement for On-Site and/or Professional Services (3332 : APPROVE THE FIRST AMENDMENT TO THE ON-SITE AND/OR



cancellation date, submit new evidence of insurance in the amounts established.

- M. Intellectual Property. Any system or documents developed, produced or provided under this Agreement, including any intellectual property discovered or developed by Contractor in the course of performing or otherwise as a result of its work, shall become the sole property of the City unless explicitly stated otherwise in this Agreement. The Contractor may retain copies of any and all material, including drawings, documents, and specifications, produced by the Contractor in performance of this Agreement. The City and the Contractor agree that to the extent permitted by law, until final approval by the City, all data shall be treated as confidential and will not be released to third parties without the prior written consent of both parties.
- N. Entire Agreement. This Agreement constitutes the entire agreement between the parties. There are no understandings, agreements, or representations of warranties, expressed or implied, not specified in this Agreement. This Agreement applies only to the current proposal as attached. This Agreement may be modified or amended only by a subsequent written Agreement signed by both parties. Assignment of this Agreement is prohibited without prior written consent.
- O. (a) The City may terminate the whole or any part of this Agreement at any time without cause by giving at least ten (10) days written notice to the Contractor. The written notice shall specify the date of termination. Upon receipt of such notice, the Contractor may continue work through the date of termination, provided that no work or service(s) shall be commenced or continued after receipt of the notice which is not intended to protect the interest of the City. The City shall pay the Contractor within thirty (30) days after receiving any invoice after the date of termination for all non-objected to services performed by the Contractor in accordance herewith through the date of termination.
- (b) Either party may terminate this Agreement for cause. In the event the City terminates this Agreement for cause, the Contractor shall perform no further work or service(s) under the Agreement unless the notice of termination authorizes such further work.
- (c) If this Agreement is terminated as provided herein, City may require Contractor to provide all finished or unfinished documents and data and other information of any kind prepared by Contractor in connection with the performance of services under this Agreement. Contractor shall be required to provide such documents and other information within fifteen (15) days of the request.
- (d) In the event this Agreement is terminated in whole or in part as provided herein, City may procure, upon such terms and in such manner as it may determine appropriate, similar to those terminated.
- P. Payment. Payments to the Contractor pursuant to this Agreement will be reported to Federal and State taxing authorities as required. The City will not withhold any sums from compensation payable to Contractor. Contractor is independently responsible for the payment of all applicable taxes. Where the

payment terms provide for compensation on a time and materials basis, the Contractor shall maintain adequate records to permit inspection and audit of the Contractor's time and materials charges under the Agreement. Such records shall be retained by the Contractor for three (3) years following completion of the services under the Agreement.

- Q. Restrictions on City Employees. The Contractor shall not employ any City employee or official in the work performed pursuant to this Agreement. No officer or employee of the City shall have any financial interest in this Agreement in violation of federal, state, or local law.
- R. Choice of Law and Venue. The laws of the State of California shall govern the rights, obligations, duties, and liabilities of the parties to this Agreement, and shall govern the interpretation of this Agreement. Any legal proceeding arising from this Agreement shall be brought in the appropriate court located in Riverside County, State of California.
- S. Delivery of Notices. All notices permitted or required under this Agreement shall be given to the respective parties at the following address, or at such other address as the respective parties may provide in writing for this purpose:

**Contractor:**

Mariposa Landscapes, Inc.  
6232 Santos Diaz St.  
Irwindale, CA 91702  
Attn: Terry Noriega, President

**City:**

City of Moreno Valley  
14177 Frederick Street  
P.O. Box 88005  
Moreno Valley, CA 92552  
Attn: Special Districts Division

Such notice shall be deemed made when personally delivered or when mailed, forty-eight (48) hours after deposit in the U.S. Mail, first class postage prepaid and addressed to the party at its applicable address. Actual notice shall be deemed adequate notice on the date actual notice occurred, regardless of the method of service.

- T. Time of Essence. Time is of the essence for each and every provision of this Agreement.
- U. City's Right to Employ Other Contractors. City reserves right to employ other contractors in connection with this project.
- V. Amendment; Modification. No supplement, modification, or amendment of this Agreement shall be binding unless executed in writing and signed by both parties.

- W. Waiver. No waiver of any default shall constitute a waiver of any other default or breach, whether of the same or other covenant or condition. No waiver, benefit, privilege, or service voluntarily given or performed by a party shall give the other party any contractual rights by custom, estoppel, or otherwise.
- X. No Third Party Beneficiaries. There are no intended third party beneficiaries of any right or obligation assumed by the parties.
- Y. Counterparts. This Agreement may be signed in counterparts, each of which shall constitute an original.
- Z. Invalidity; Severability. If any portion of this Agreement is declared invalid, illegal, or otherwise unenforceable by a court of competent jurisdiction, the remaining provisions shall continue in full force and effect.
- AA. Assignment or Transfer. Contractor shall not assign, hypothecate, or transfer, either directly or by operation of law, this Agreement or any interest herein without the prior written consent of the City. Any attempt to do so shall be null and void, and any assignees, hypothecates or transferees shall acquire no right or interest by reason of such attempted assignment, hypothecation or transfer.
- BB Supplementary General Conditions (for projects that are funded by Federal programs). The following provisions, pursuant to 44 Code of Federal Regulations, Part 13, Subpart C, Section 13.36, as it may be amended from time to time, are included in the Agreement and are required to be included in all subcontracts entered into by CONTRACTOR for work pursuant to the Agreement, unless otherwise expressly provided herein. These provisions supersede any conflicting provisions in the General Conditions and shall take precedence over the General Conditions for purposes of interpretation of the General Conditions. These provisions do not otherwise modify or replace General Conditions not in direct conflict with these provisions. Definitions used in these provisions are as contained in the General Conditions.
1. CONTRACTOR shall be subject to the administrative, contractual, and legal remedies provided in the General Conditions in the event CONTRACTOR violates or breaches terms of the Agreement.
  2. CITY may terminate the Agreement for cause or for convenience, and CONTRACTOR may terminate the Agreement, as provided the General Conditions.
  3. CONTRACTOR shall comply with Executive Order 11246 of September 24, 1965, entitled Equal Employment Opportunity, as amended by Executive Order 11375 of October 13, 1967, and as supplemented in Department of Labor regulations (41 CFR chapter 60). (All construction contracts awarded in excess of \$10,000 by CITY and/or subcontracts in excess of \$10,000 entered into by CONTRACTOR.)
  4. CONTRACTOR shall comply with the Copeland Anti-Kickback Act (18 U.S.C. 874) as supplemented in Department of Labor regulations (29 CFR Part 3) (All contracts and subcontracts for construction or repair.)

5. CONTRACTOR shall comply with the Davis-Bacon Act (40 U.S.C. 276a to 276a7) as supplemented by Department of Labor regulations (29 CFR Part 5).
6. CONTRACTOR shall comply with Sections 103 and 107 of the Contract Work Hours and Safety Standards Act (40 U.S.C. 327330) as supplemented by Department of Labor regulations (29 CFR Part 5).
7. CONTRACTOR shall observe CITY requirements and regulations pertaining to reporting included in the General Conditions.
8. Patent rights with respect to any discovery or invention which arises or is developed in the course of or under the Agreement shall be retained by the CITY.
9. Copyrights and rights in data developed in the course of or under the Agreement shall be the property of the CITY. FEMA/CalOES reserve a royalty-free, nonexclusive, irrevocable license to reproduce, publish or otherwise use or authorize to others to use for federal purposes a copyright in any work developed under the Agreement and/or subcontracts for work pursuant to the Agreement.
10. CONTRACTOR shall provide access by the City, the Federal grantor agency, the Comptroller General of the United States, or any of their duly authorized representatives to any books, documents, papers, and records of the contractor which are directly pertinent to that specific contract for the purpose of making audit, examination, excerpts, and transcriptions.
11. CONTRACTOR shall retain all required records for three years after CITY makes final payments and all other pending matters relating to the Agreement are closed.
12. CONTRACTOR shall comply with all applicable standards, orders, or requirements issued under section 306 of the Clean Air Act (42 U.S.C. 1857(h)), section 508 of the Clean Water Act (33 U.S.C. 1368), Executive Order 11738, and Environmental Protection Agency regulations (40 CFR part 15). (This provision applies to contracts exceeding \$100,000 and to subcontracts entered into pursuant to such contracts.)
13. CONTRACTOR shall comply with mandatory standards and policies relating to energy efficiency which are contained in the State energy conservation plan issued in compliance with the Energy Policy and Conservation Act (Pub. L. 94163, 89 Stat. 871).

**SIGNATURE PAGE TO FOLLOW**

IN WITNESS HEREOF, the parties have each caused their authorized representative to execute this Agreement.

Moreno Valley Community Services District

Mariposa Landscapes, Inc.

By: [Signature]  
Title: Thomas M. DeSantis, City Manager,  
Acting in the capacity of District  
Manager to the Moreno Valley  
Community Services District

By: [Signature]  
Title: (President or Vice President)

Date: 6.27.18

Date: 6/25/18

By: [Signature]  
Title: Corporate Secretary or Assistant  
Secretary

Date: 6/25/18

Affix Corporate Seal Below

**INTERNAL USE ONLY**

ATTEST:

\_\_\_\_\_  
City Clerk  
*(only needed if Mayor signs)*

APPROVED AS TO LEGAL FORM:

\_\_\_\_\_  
City Attorney  
6-26  
Date

RECOMMENDED FOR APPROVAL:

\_\_\_\_\_  
Department Head  
*(if contract exceeds 15,000)*  
6/27/18  
Date



Attachment: Agreement for On-Site and/or Professional Services (3332 : APPROVE THE FIRST AMENDMENT TO THE ON-SITE AND/OR

## EXHIBIT A – SCOPE OF WORK

### LANDSCAPE MAINTENANCE

#### 1. GENERAL PROVISIONS

- A. The work to be performed under this agreement shall include the furnishing of all labor, material, and equipment necessary for the provision of landscape, irrigation and appurtenant maintenance services within the boundaries of the various City landscape maintenance districts, zones, or City responsible landscape areas as determined in the resolutions or agreements of the City Council and/or Community Services District Board establishing said landscape maintenance, zones, or City responsible landscape areas and as said boundaries may have been heretofore or may be hereafter amended, and as more particularly shown on the Location Map or Maps included herein.
- B. The Contractor shall have the duty to: mow, edge, trim, and fertilize turf, groundcover, and shrub areas designated hereunder; regularly maintain and prune those portions of trees up to eighteen feet (18') in height; remove litter and debris from all sites as required under this agreement; provide general pest control services as requested, including but not limited to weeds, insects, vertebrate pests, and diseases; maintain irrigation systems; hand water and bleed valves as necessary during emergencies when automatic systems are not functioning; complete and submit required reporting forms as provided herein or as may be added from time to time; and submit invoices in a timely manner and in detail by and for each landscape area to include specific reference to WQB ID, Median ID, Tract ID, LMD zone or CFD area for which work was completed.
- C. All work shall be performed in accordance with usual and customary horticultural practices to achieve, and maintain healthy, viable landscapes. The Public Works Director of the City of Moreno Valley, or his/her delegated representative(s), hereinafter designated as "Director" will periodically inspect all the operations and approve or reject the work performed, and methods or materials used, and make changes in the work scheduling.
- D. The Contractor shall be responsible for carefully reviewing the site(s), and verifying the square footage noted for each location of proposed work included in the Proposal. The Contractor shall not be relieved of his/her/its liability under this agreement, nor shall the City be held liable for any loss sustained by the Contractor for any variance between conditions as referred to herein and the actual conditions revealed during the examination of the locations of the proposed work.

- E. All work shall be performed in accordance with the provisions of this agreement and in accordance with an approved service schedule, as approved by the Director. Service schedules may be modified with 30 days advance written notice by the City.
- F. Failure to adhere to comply with any provisions included herein may result in the assessment of non-performance penalties per Exhibit C.
- G. All equipment used in the performance of work under this agreement shall be compliant with the current regulations of the California Air Resources Board.

## 2. TURF CARE

- A. All turf areas shall be mowed, edged, and trimmed per the Frequency of Services Table, as set forth in Exhibit E, Schedule II. Should weather and/or site conditions preclude the normally scheduled frequency of this service during any month, or portion thereof, the maintenance schedule shall be modified at the discretion and approval of the Director.
- B. At the discretion of the Director, turf areas may be mowed with mulching-type mowers of a type acceptable to the City.
- C. All mowing and edging equipment shall: be in proper working order; have blades properly sharpened, balanced, and aligned; be thoroughly cleaned of all excess clippings, soil, and debris prior to move-in at each site.
- D. All clippings, soil, and debris generated by mowing and edging operations shall be immediately collected, removed from the site, and disposed of in a legal manner. For the purposes of this Specification the term "site" shall include, but is not limited to, appurtenant hardscaping, sidewalks, curbs and gutters.
- E. Machines operating on turf known to have a disease, fungus, or insect infestation shall be sterilized with a ten percent (5%) chlorine bleach, and water solution prior to move-in to any other site.
- F. Mowing height for cool season grasses shall not exceed three inches (3") maximum, or two inches (2") minimum, and shall be adjusted within these parameters on a seasonal basis.
- G. Mowing height for warm season grasses shall not exceed one and one-half inches (1½") maximum, or three-quarters of an inch (¾") minimum, and shall be adjusted within these parameters on a seasonal basis.
- H. All turf borders shall be cut with a vertical blade edger. Use of string trimmers to perform this task is not acceptable.

- I. Trimming around turf appurtenances (i.e., valve and meter boxes, backflow devices and controller enclosures, sprinklers) may be accomplished with use of string trimmers.
- J. Whenever trees occur in turf areas, a six-inch (6") ring of grass shall be removed from around the trunks to protect the crowns from mechanical damage. These rings shall be maintained in a clean, weed free condition.
- K. Thin areas in turf shall be resodded or reseeded as necessary to prevent invasion of weeds.
- L. Fertilization. See Fertilizer Use.
- M. Pest Control. See Pesticide Use.
- N. Aeration. All turf areas shall be aerated per the Frequency of Service Table, as set forth in Exhibit E, Schedule II, unless otherwise directed by the Director.
  - 1. Aeration equipment shall be of the hollow tine type. The tines shall have a minimum diameter of one-half inch ( $\frac{1}{2}$ "), and a penetration depth of at least two inches (2"). There shall be no more than six inches (6") between tines; Areas to be treated shall be adequately irrigated prior to treatment to allow maximum tine penetration.
  - 2. Any soil cores remaining on the turf surface two (2) week after treatment must be removed.
  - 3. Humus base fertilizer is to be applied directly following spring and fall aeration operations.
  - 4. Renovation/thatching and additional aeration operations are to be considered Additional Work, per Exhibit C.

### 3. TREE CARE

- A. All trees are to be maintained in a manner that will promote normal, healthy growth.
- B. For the purposes of these Specifications, trimming, pruning, and pest control operations for those portions of trees greater than eighteen feet (18') in height is to be considered Additional Work, per Exhibit C.
- C. Whenever site conditions permit, trees are to be allowed to grow to assume their full, natural shape, with the minimum constraints necessary to assure public safety and tree survival. All tree pruning shall be done in conformance with ANSI 300-2001, (or most current revision); safety requirements shall be per ANSI Z133-1994 (or most current revision) standards.
- D. The Contractor or any subcontractors working under Contractor's direction and control must observe all restrictions on the unauthorized take of migratory



birds, as set forth in the U.S. Fish and Wildlife Service Migratory Bird Treaty Act (MBTA), including but not limited to Sections 703-713 and the California Department of Fish and Game Code sections 3503, 3503.5, and 3513.

- E. Trees shall be pruned at any time to:
1. Remove dead, diseased, or damaged branches.
  2. Remove unwanted encroachments into public and/or utility rights-of-way.
  3. Correct any condition which the Director has deemed to be hazardous.
- F. Portions of trees up to eighteen feet (18') in height shall:
1. Be pruned to enable successful adaptation to their particular site situation.
  2. Have no more than one-third (1/3) of living branches removed annually.
  3. Be fertilized only as directed by the City field staff.
- G. Portions of trees over eighteen feet (18') in height shall:
1. Be inspected annually.
  2. Pruned and/or trimmed as necessary to maintain proper site orientation.
  3. Pruned and/or trimmed as necessary to remove unwanted encroachments into public, and/or utility rights-of-way.
  4. Pruned and/or trimmed as necessary to correct any condition which the Director has deemed to be hazardous.
  5. Pruned to remove any impediment to the proper conveyance of nuisance and/or storm water flows through a water quality facility.
- H. Pruning tools shall:
1. Be kept properly sharpened, and in proper working order.
  2. Be sterilized with five percent (5%) chlorine bleach and water solution before commencing work, and between cuts on any tree known to be diseased.
- I. The following practices shall not be allowed:
1. Internodal cuts of any kind (a.k.a. "stubbing", "shearing", "tipping", "topping").
  2. Cuts made flush with trunk or branch. The integrity of branch collars is to be maintained at all times.
  3. Use of pruning paint/pruning compound/wound dressing.
  4. Use of climbing spurs or gaffs.
- J. All prunings/trimmings and debris generated by pruning operations shall be immediately removed from the site, and disposed of in a legal manner.

- K. Trees shall be staked/guyed in a manner, and with materials that are acceptable to the Director. Double staking with two (2) lodge pole-type stakes is the minimum City standard.
- L. Tree stakes, tree ties, and guy wires shall be inspected regularly to ensure against girdling and abrasion, and removed as soon as possible after tree establishment, and site conditions allow.
- M. Pest Control. See Pesticide Use.

#### 4. SHRUB CARE

- A. All shrubs are to be maintained in a manner that will promote normal, healthy growth.
- B. For the purposes of these Specifications, shrubs are defined as any multi-stemmed/low branching woody plants whose height at maturity is not less than one foot (1'), or greater than ten feet (10').
- C. Whenever site conditions permit, shrubs are to be allowed to grow to assume their full, natural shape, with the minimum constraints necessary to assure public safety and plant survival.
- D. Shrubs shall be pruned and/or trimmed per the Frequency of Service Table, as set forth in Exhibit E, Schedule II, unless otherwise directed by the Director, to:
  - 1. Remove dead, diseased, or damaged branches.
  - 2. Remove unwanted encroachments into public and/or utility rights-of-way.
  - 3. Correct any condition which the Director has deemed to be hazardous.
- E. Shrubs shall be pruned in a manner that will:
  - 1. Enable successful adaptation to their particular site situation.
  - 2. Follow the maturation of the leaves/needles of the first seasonal growth flush, unless accepted practices for a particular species (i.e. roses) dictate otherwise.
- F. Pruning tools must:
  - 1. Be kept properly sharpened, and in proper working order.
  - 2. Be sterilized with a five percent (5%) chlorine bleach and water solution before commencing work, and between cuts on any shrub known to be diseased.

G. The following practices are not allowed:

1. Internodal cuts (e.g. "stubbing", "tipping", "topping"). Shearing (e.g. "boxing", "hedging", "balling", "poodling") will be done only when authorized by the Director on a site-specific basis.
2. Cuts made flush with trunk or branch. The integrity of branch collars is to be maintained at all times.
3. Use of pruning paint/pruning compound/wound dressing.

H. Fertilization. See Fertilizer Use.

I. Pest Control. See Pesticide Use.

## 5. GROUND COVER CARE

A. All ground covers are to be maintained in a manner that will promote normal, healthy growth.

B. For the purposes of these Technical Provisions, ground covers are defined as mass plantings of same-species, multi-stemmed plants with a trailing growth habit, whose height at maturity does not exceed  $\pm$  one foot (1').

C. Ground covers shall be pruned/trimmed per the Frequency of Service Table, as set forth in Exhibit E, Schedule II, unless otherwise directed by the Director to:

1. Remove dead, diseased, or damaged branches/crowns.
2. Remove unwanted encroachments into or upon public and/or utility rights-of-way, as well as other landscape components (i.e., shrubs, trees, turf areas, irrigation equipment, walls, and monuments).
3. Remove any impediment to the proper conveyance of nuisance and/or storm water flows through a water quality facility.
4. Correct any condition which the Director has deemed to be hazardous.

D. Ground covers shall be pruned/trimmed/renovated:

1. To enable successful adaptation to their particular site situation,
2. In accordance with accepted practices for the particular species in question.

E. Pruning tools shall:

1. Be kept properly sharpened, and in proper working order.
2. Be sterilized with a five percent (5%) chlorine bleach and water solution before commencing operations at any site.

F. String trimmers shall not be used for any of the above described operations unless authorized by the Director on a site-specific, task-specific basis.

G. Fertilization. See Fertilizer Use.

H. Pest Control. See Pesticide Use.

## 6. CHANNEL AND HABITAT CARE

The channel thinning zones will be subject to long-term management practices for flood control work. The channel-thinning zones are comprised of the two 40-foot-wide thinning zones. Beyond the 40-foot channel-thinning zones, removal of native vegetation shall be allowed only to assure proper operation of slope buffer area irrigation systems, to perform permitted fire protection activities, and to eliminate any hazardous condition for public safety.

The Contractor or any subcontractors working under Contractor's direction and control must observe all restrictions on the unauthorized take of migratory birds, as set forth in the U.S. Fish and Wildlife Service Migratory Bird Treaty Act (MBTA), including but not limited to Sections 703-713 and the California Department of Fish and Game Code sections 3503, 3503.5, and 3513.

### A. Vegetative Thinning

1. When vegetation and removal is deemed necessary by the City, and regulatory permits are in place to provide for adequate flood protection, the City shall determine if the work shall be accomplished by hand crews, mechanical equipment, or a combination of available resources. In reaching this determination, careful consideration shall be given to the mutual goal of minimizing negative impacts throughout the mitigation site and continuing to allow the drainage to function as a flood control channel designed to support 100-year flood flows.
2. The channel thinning zones will be maintained annually by mowing or removing vegetation above the existing soil level not to exceed two feet (24-inches) in height so that all channels will support 100-year flood flows.
3. For maintenance of channel the Contractor may use:
  - a. Four-wheel-drive all-terrain vehicle (ATV) type maintenance vehicles to haul personnel, equipment, trash, trimmings, weeds, and debris.
  - b. A 30-40 horsepower utility tractor with bucket and mower for mowing channel bottoms.
  - c. A skip-loader and/or backhoe as required to effect irrigation mainline repairs in areas accessible to this type of equipment.

### B. Timing of Vegetative Thinning

1. The Contractor will perform maintenance services within the 40-foot wide thinning zones pursuant to existing City policies, guidelines, and regulations, and required regulatory permits, including but not limited to National Pollutant Discharge Elimination System (NPDES) permits, and community obligations to maintain flood carrying capacity within all

channels, as required under FEMA's LOMR, dated September 27, 2004, and required regulatory permits. The contractor shall conduct the annual vegetative thinning program within the 40-foot wide thinning zones, outside the bird nesting season and consistent with the U.S. Fish and Wildlife Service Migratory Bird Treaty Act (MBTA). If annual vegetative thinning must occur during the nesting season, this activity will be authorized if the vegetation to be thinned represents a threat to public safety and/or biological surveys confirming the absence of nesting birds occurs at this time as well.

### C. Pesticide Use and Weeding

1. Use of herbicides, pesticides, rodenticides, biocides, fertilizers, or other agricultural chemicals or weed abatement activities shall be limited pursuant to existing City policies and guidelines, and/or as described herein.
2. The Contractor will conduct weed abatement on a quarterly basis including, but not limited to, the exotic plant species listed herein. Weeds shall be removed by hand, including the root, or controlled with an appropriate herbicide as determined by a licensed Pest Control Advisor (PCA). The use of herbicides for weed control within the channel shall be used for species such as Bermuda grass (*Cynodon dactylon*), giant reed (*Arundo donax*), bindweed (*Convolvulus arvensis*), and salt cedar (*Tamarix sp.*). Only pesticides approved for use within stream courses shall be authorized for use within all channel areas.
3. All weeds shall be removed from the mitigation site and/or controlled at all times.
4. Weeds are defined as "any plant species whose presence on a site is detrimental to the appearance of the site and the normal, healthy growth of plant materials intended for the site." All plants that constitute a public health or safety hazard shall also be considered weeds. Examples of weeds to be controlled include, but are not limited to:
  - d. Arundo/giant reed (*Arundo donax*);
  - e. Artichoke thistle/cardoon (*Cynara cardunculus*);
  - f. Australian saltbush (*Atriplex semibaccata*);
  - g. Bermuda grass (*Cynodon dactylon*);
  - h. Biennial mustard (*Hirschfeldia incana*);
  - i. Black mustard (*Brassica nigra*);
  - j. Broom species (*Cytisus spp.*);
  - k. Bull thistle (*Cirsium vulgare*);
  - l. Canary Island date palm (*Phoenix canariensis*);
  - m. Castor bean (*Ricinis communis*);

- n. Cootamundra wattle (*Acacia baileyana*);
- o. Fennel (*Foeniculum vulgare*);
- p. Filaree/Storcksbill (*Erodium* spp.);
- q. Foxtail chess (*Bromus madritensis*);
- r. Hottentot fig (*Carpobrotus edulis*);
- s. Italian ryegrass (*Lolium multiflorum*);
- t. Italian thistle (*Carduus pycnocephalus*);
- u. Ivy (*Hedera* spp.);
- v. Japanese honeysuckle (*Lonicera japonica*);
- w. Kikuyu grass (*Pennisetum clandestinum*);
- x. Pampas grass (*Cortaderia jubata*; *C. selloana*);
- y. Periwinkle (*Vinca major*);
- z. Peruvian pepper tree (*Schinus molle*);
- aa. Rabbitsfoot grass (*Polypogon monspeliensis*);
- bb. Red valerian (*Centranthus ruber*);
- cc. Ripgut brome (*Bromus diandrus*);
- dd. Russian thistle (*Salsola tragus*);
- ee. Slender oats (*Avena barbata*);
- ff. Soft chess (*Bromus hordeaceus*);
- gg. Tamarisk (*Tamarix ramosissima*, *T. parviflora*);
- hh. Tree tobacco (*Nicotiana glauca*);
- ii. Umbrella sedge (*Cyperus involucratus*);
- jj. Water bent grass (*Agrostis viridis*); and
- kk. Wild oat (*Avena fatua*).

#### D. Trash and Debris Removal

1. The mitigation site shall be kept free of trash and debris in perpetuity. Trash and debris removal shall occur in accordance with the Frequency of Services schedule (Exhibit E, Schedule II). If trash and debris removal is required during the bird-nesting season, this will be allowed pursuant to required regulatory permits, and/or in order to protect public safety. Care will be taken so that trash removal activities minimize or avoid impacts to existing native plants.

E. Access to Channel

1. Channel access may be attained via the access road adjacent to the Pedestrian Bridge at the western end of the channel or through the three gates located along Hastings Drive on the northern side of the channel. Pedestrian access shall be authorized for all maintenance or authorized personnel. Care shall be taken to avoid impacts to existing vegetation outside the channel-thinning zones.

F. Mulefat Scrub Area

1. Existing Mulefat Scrub areas must be left undisturbed.

**7. OPEN SPACE AREA (PASEO) CARE**

- A. All open space (paseo) areas shall be maintained in a condition free of unwanted plant species, as determined by the Director.
- B. Non-woody plants, such as grasses and annual forbs shall be trimmed to a height of twenty-four (24) inches or lower at a frequency of no less than one (1) time per year, as determined by the Director.
- C. Woody slope plantings shall be maintained in a manner that minimizes the accumulation of dead wood. This shall be accomplished by means of periodic trimming, pruning, and/or roguing, as determined by the Director.
- D. A band of bare soil, twenty-four (24) inches in width shall be maintained per the Frequency of Service Table wherever Open Space (Paseo) areas abut residential parcels.
- E. Newly planted and/or established tree and woody shrub plantings shall receive irrigation adequate to maintain soil moisture and plant vigor; in no case shall the interval between irrigations be greater than once per week. This work may require the use of a water tanker. Contractor shall be liable for replacement of any new or establishing plan materials lost due to Contractor's negligence, as determined by Director.
- F. Watering basins for newly planted and/or establishing tree and woody shrub plantings shall be continuously maintained and kept free of unwanted plant species until properly established, as determined by the Director.
- G. All areas damaged by erosion shall be immediately repaired to the originally intended condition and soil. Contractor shall be liable for the cost of repairing all erosion damage caused by Contractor's negligence.
- H. All areas damaged by rodent burrowings shall be immediately repaired to the originally intended condition and soil.

- I. All catch basins, drain lines, brow ditches, and lower slope swale areas shall at all times be kept clean and clear for proper drainage.
- J. Minimum flow channels shall be maintained in a manner that assures unimpeded flow of nuisance water per limits of design intent. This work may require periodic thinning/rouging of existing riparian plants, as determined by Director.

## **8. WATER QUALITY BASIN BOTTOM & FOREBAY / OUTLET STRUCTURE / SAND BED MAINTENANCE**

### **A. Basin Bottom Vegetation**

1. Water Quality Basin bottom vegetation shall be mowed / trimmed to a height of twelve inches (12") at least one (1) time annually, or as needed to ensure that the facilities function per design intent, per the frequency of service table, as set forth in Exhibit E, unless otherwise stated herein this section and/or as directed by the Director. Annual mowing / trimming operations shall be initiated no earlier than August 15, and concluded no later than October 1.
2. Machinery / equipment selected to perform mowing / trimming operations shall be operated in a manner that does not: damage or alter basin bottom or basin slope topography, or; damage or render inoperable basin bottom or slope irrigation systems. Any damage to, or alteration of basin bottom or slope topography, or damage of basin bottom or slope irrigation systems resulting from Contractor's (or sub-contractor's) operations shall be repaired immediately at Contractor's sole expense.
3. Debris generated by mowing / trimming operations shall be immediately removed from the sites, and disposed of and/or recycled in a legal manner

### **B. Concrete and/or Earthen Forebays and Outlet Structures**

1. Concrete / earthen forebays and outlet structures shall be cleaned of debris and vegetation at least two (2) times annually, or as needed to ensure that they function per design intent. Scheduled cleanout operations shall be conducted in the spring and fall of the year, no later than May 31 and October 1, respectively per the frequency of service table, as set forth in Exhibit E, unless otherwise stated herein this section and/or as directed by the Director.
2. Machinery / equipment selected to perform cleanout operations shall be operated in a manner that does not alter or damage channel surfaces. Any damage to, or alteration of, channel surfaces resulting from Contractor's (or sub-contractor's) operations shall be repaired immediately at Contractor's sole expense.



3. Debris generated by channel cleanout operations shall be immediately removed from the sites, and disposed of and/or recycled in a legal manner.

#### C. Sand Bed

1. Inspect semi-annually for standing water, sediment, trash, and debris; remove accumulated trash and debris from the sand bed, as necessary.
2. Scarify (rake) the top of sand bed to a depth of three (3) inches semi-annually.
3. When the Director determines that the sand bed does not drain within seventy-two (72) hours, Contractor shall remove the top three (3) inches of sand and replace with new sand to return the sand layer to the original depth.
4. When the Director determines that scarification or removal of the top three (3) inches of sand layer is no longer effective, Contractor shall remove and replace the entire sand filter layer.
5. Debris generated by sand bed maintenance operations, including but not limited to those described above, shall be immediately removed from the sites, and disposed of in a legal manner.

### 9. WEED CONTROL

- A. For the purposes of these Specifications, weeds are defined as any plant species whose presence on a site is detrimental to: the appearance of the site, as determined by the Director, and the normal, healthy growth of the plant materials intended for that site. Any plants which, in the opinion of the Director, constitute a public health or safety hazard shall also be defined as weeds.
- B. Weed control shall be addressed per the Frequency of Service Table, as set forth in Exhibit E, Schedule II unless otherwise stated herein and/or as directed by the Director.
- C. Site areas subject to weed control per these Specifications include, but are not limited to: turf areas, tree wells, shrub, planter, and ground cover beds; hardscape areas, including, but not limited to curbs, gutters, and sidewalks; and non-landscaped portions of sites, as determined by the Director.
- D. Debris generated by manual and/or mechanical weed control operations shall be immediately removed from the site, and disposed of in a legal manner.
- E. Chemical Weed Control. See Use of Chemicals.

## 10. IRRIGATION

- A. Irrigation shall be maintained and tested per the Frequency of Service Table, as set forth in Exhibit E, Schedule II, unless otherwise stated herein and/or as directed by the Director.
- B. Water shall be delivered by means of automatic or manually operated sprinkler systems, quick couplers, hose bibbs, or water tank, as specific site and/or weather conditions require.
- C. It shall be the Contractor's duty to maintain all City irrigation systems in a manner that assures their full working capability at all times. Said maintenance shall include, but not be limited to: visual and operational inspections; cleaning/adjusting sprinkler nozzles; flushing of lines; trimming around sprinklers to assure proper coverage; routine repairs; and other tasks as assigned by City field staff.
- D. For the purposes of this section, routine irrigation repairs are defined as repair and/or replacement of existing sprinklers or sprinkler components and/or non-pressurized pipe and/or fittings ("lateral lines") that have been rendered inoperable due to: 1) normal operation ("wear and tear"), and; 2) vandalism, theft, and acts or omissions by third parties.
- E. All repairs to, and/or replacement of, irrigation system control components (i.e., backflow prevention assemblies, controllers and control wires, manual and remote control valves) and pressurized pipe and fittings ("mainlines") rendered inoperable due to circumstances other than Contractor's operations, shall be considered Additional Work, per Exhibit C.
- F. The Contractor shall furnish, at no cost to the City, a remote valve actuating device that is compatible with the make, and model installed at the site(s). This device shall be used by Contractor's personnel while conducting operational irrigation system inspections, and/or repairs.
- G. Manually operated irrigation systems shall:
  - 1. Be operated only when Contractor's personnel are present on site.
  - 2. Be turned off during periods of rainfall or as directed by City field staff.
  - 3. Be inspected for, and repaired as necessary to ensure proper operation and coverage not less than at each time of operation.
  - 4. Have any and/or all enclosures, vaults, and valve boxes properly secured at all times.
- H. Automatic irrigation systems shall:
  - 1. Be inspected for and repaired as necessary to ensure properly operation and coverage.
  - 2. Be turned off during periods of rainfall or as directed by City field staff.

3. Have any and/or all enclosures, vaults, and valve boxes properly secured at all times.
- I. Parts/components used to effect irrigation system repairs shall be of the same manufacturer as those originally installed unless otherwise approved by the Director prior to repair operations.

## 11. DEBRIS AND LITTER

- A. Debris/litter control shall be provided per the Frequency of Service Table, as set forth in Exhibit E, Schedule II, unless otherwise stated herein and/or as directed by the Director.
- B. The Contractor shall remove immediately after pruning, trimming, weeding, edging or other work required under this agreement, all debris generated by his or her performance of the work.
- C. Contractor shall remove from both planted areas and adjacent hardscapes/walkways the following items, which include but are not limited to: bottles, cans, paper/plastic, cardboard, dog litter, tumbleweeds/ windblown plant litter, automobile tires, or metallic items. Sites that are, in the opinion of the Director, exceptionally littered shall be cleared by the Contractor before the close of business the working day following notification of this condition.
- D. All hardscape areas that include, but are not limited to sidewalks, curbs, and gutters shall be maintained in a hazard-free condition.
- E. The Contractor shall dispose of all debris and litter off-site and in a legal manner.
- F. The Contractor shall notify the Director immediately whenever suspicious and/or hazardous waste materials are discovered within service area sites. Such materials may include, but are not limited to: discarded motor oil, or other petroleum-based liquids; paint; chemical compounds, pesticides, both liquid and dry; any unknown liquid or dry material in an unmarked container; household appliances; household electronic devices such as; televisions, computers and computer monitors; firearms, ammunition or other appliances. Any such articles shall not be touched, handled, or in any way disturbed or moved from the location where they were discovered. Contractor's staff shall secure the area against entry by any third party until City staff arrives at the site.

## 12. FERTILIZER USE

- A. General.
  1. Fertilizer shall be used per the Frequency of Service Table, as set forth in Exhibit E, Schedule II, unless otherwise stated herein and/or as directed by the Director.

2. At the discretion and request of the Director, additional applications may be provided at the pricing terms listed in the Additional Work section of Exhibit E, Scheduled II.
3. Any granular fertilizer material deposited on adjacent hardscaping, including but not limited to sidewalks, gutters, pavement, concrete forebays, utility vaults, or the sand bed, shall be collected immediately and redistributed evenly across the targeted area or removed from the site and disposed of in a legal manner. In no circumstance shall fertilizer material be allowed to enter the site's storm drain system.
4. Any fertilizers containing iron will be completely removed from concrete sidewalks before irrigation to prevent staining.
5. Written notification to Director must be provided five (5) working days prior to fertilizer application.
6. Contractor shall supply to the Director a list of all proposed fertilizers to be used in the fulfillment of said agreement and per Exhibit E, Schedule II. Any changes to said list shall be reported per Exhibit E, Schedule II.
7. Contractor shall comply with any federal, state, or local reporting requirements.

B. Turf Fertilization

1. A humus base fertilizer shall be applied to turf areas.
2. All turf areas are to be fertilized as per Table I. All fertilizers are to be of indicated analysis or better.

| TABLE I – Turf Fertilization  |                        |                    |                         |                    |
|---|------------------------|--------------------|-------------------------|--------------------|
|   |                        |                    | Rates per 1,000 sq. ft. |                    |
| Month   | Number of Applications | Type of Fertilizer | Lbs. of Actual N        | Lbs. of Fertilizer |
| February  | 1                      | 22-0-6**           | 1                       | 4.5 lbs.           |
| June  | 1                      | 22-5-5*            | 1.25                    | 5.7 lbs.           |
| October   | 1                      | 22-5-5*            | 1.25                    | 5.7 lbs.           |
| *22-5-5/BEST® TURF GOLD or approved equal Controlled-Release fertilizer. These fertilizers to contain micronutrients including iron. See the following section on fertilizers.                      |                        |                    |                         |                    |
| **22-0-6/SCOTTS® PROTURF® + Pre-emergent Weed Control or approved equivalent. These fertilizers to contain micronutrients including iron. See the following sections, below, regarding fertilizers. |                        |                    |                         |                    |

3. Humus base fertilizers to be applied by drop spreader only.
4. Humus base fertilizers to be composted, screened, and have a minimum nitrogen level of one-half of one percent (0.5%) (Growpower, EZ Green or equal).

C. Shrub and Ground Cover Fertilization

1. All shrubs and ground covers shall be fertilized in accordance with the standard fertilization guidelines identified in Table II below. However, the frequency of the application shall comply with the application frequency

rates as identified in the Frequency of Service Table, as set forth in Exhibit E, Schedule II.

| TABLE II – Shrub and Ground Cover Fertilization |                |                    |                         |                    |
|---|----------------|--------------------|-------------------------|--------------------|
|   |                |                    | Rates per 1,000 sq. ft. |                    |
| Month   | Number of Apps | Type of Fertilizer | Lbs. of Actual N        | Lbs. of Fertilizer |
| April   | 1              | 23-5-10 *          | 1.5                     | 6.5 lbs.           |
| September                                       | 1              | 23-5-10 *          | 1.5                     | 6.5 lbs.           |
| * 23-5-10/BEST@POLY SUPREME or approved equal   |                |                    |                         |                    |

D. Tree Fertilization

1. The intent of tree fertilization is to maintain normal and healthy growth of trees, not to produce excessive, rapid, or unnatural growth. Tree fertilization shall be considered Additional Work, per Exhibit C.
2. All trees shall be fertilized as directed by City field staff. Fertilizer type and rates will be specified on a per job basis.
3. Fertilizer will be placed per manufacturer's recommendations, or as directed by City and/or District field staff.
4. No injecting or drilling into tree trunk will be allowed.
5. Applications shall be made when the first growth flush of the year is at 80% leaf expansion, but not before April 30.

13. PESTICIDE USE

A. General

1. The City of Moreno Valley and the Moreno Valley Community Services District encourages the use of effective alternative pest control measures.
2. All pesticide applications shall be made by or under the supervision of a person holding a valid license, permit or certificate issued pursuant to Sections 11701 and following, and Sections 14151 and following, of the California Food and Agricultural Code. Said person or Contractor is to be registered to conduct a pest control business in the State of California, and the County of Riverside during the entire term of this agreement.
3. All pesticide applications shall be applied as directed by the Director.
4. All pesticide use recommendations shall be in writing, and shall be made by a person holding a valid State of California pest control adviser license pursuant to Sections 12001, and following of the California Food and Agricultural Code. Said person is to be registered with the office of the Agricultural Commissioner of the County of Riverside during the entire term of this agreement.
5. Before the beginning of the agreement period, Contractor shall supply to the Director a list of all proposed pesticides to be used, along with a use recommendation for each pesticide. No pesticide application shall be made prior to Contractor's submittal and Director's approval of said list,

and recommendations. Any changes, additions, deletions or substitutions to the recommended pesticides listed shall be submitted in writing to the Director for approval prior to any use of newly recommended material.

6. Disposal of empty pesticide containers, if made in the County of Riverside, shall be in strict compliance with label direction, restrictions and precautions, and all applicable federal, state, county, and local regulations, including but not limited to California Code of Regulations, Sections 6684, 3142, and 3143. The Director may require proof of such compliance in the form of a copy of a Contractor's annual Letter of Compliance, as issued by the County Agricultural Commissioner, and submitted by Contractor to the County Waste Management Department.
  7. Snail Control
    - a. Snails shall be controlled on a regular basis on the following plant species:
      - i. *Agapanthus africanus*
      - ii. *Aptenia sp.*
      - iii. *Gazania sp.*
      - iv. *Hemerocallis sp.*
    - b. Snails shall be controlled on an as needed basis on all other plant material.
  8. Vertebrate Pest Control
    - a. All vertebrate pests, including but not limited to gophers, ground squirrels, moles, voles, and mice, shall be controlled on a regular basis wherever and whenever found on the site(s).
    - b. Control methods shall be as approved by the Director and shall include, but not be limited to, chemical, and mechanical methods.
    - c. Failure to treat site(s) for vertebrate pests within seven (7) calendar days of notification from the Director may result in the assessment of non-performance penalties, per Exhibit C.
    - d. Landscape areas shall be inspected and treated as necessary a minimum of one (1) time per month unless otherwise noted in the Frequency of Services Table or as determined by the Director.
- B. Reporting Specifications
1. Contractor shall be responsible for the filing of all required records and reports, including but not limited to Notice of Intent to Apply, and Pesticide Use Reports, as specified by all county, state and federal agencies. Said reports shall contain accurate and valid information. The Director may require copies of all such records and reports be made available for inspection by City staff after giving twenty-four (24) hour notice to Contractor.

2. A written notice shall be provided to the Director five (5) working days prior to any pesticide application. Notice shall include name of chemical, area, rate and method of application, and time of day.
- C. Ground Covers, Shrubs, and Trees Pesticide Usage Criteria
1. Weed Control
    - a. All shrub bed areas shall be treated with an appropriate pre-emergent herbicide at the maximum allowable rate according to the label, and state regulations. This treatment shall be performed per the Frequency of Services Table, Exhibit E, Schedule II.
  2. Appropriate chemical control must be used on the following weeds.
    - a. Bermuda Grass
    - b. Kikuyu Grass
    - c. Nutsedge
    - d. Field Bindweed
    - e. Spurge
    - f. Any other species deemed necessary by the Director
- D. Insect and Disease Control
1. The Director may require certain tree species, which are subjected to excessively dusty conditions, be rinsed off with water, as directed by City field staff. Rinsing operations that require the use of powered delivery systems shall be considered Additional Work, per Exhibit C.
  2. The Director may require all Platanus species be sprayed annually with two applications of a copper based dormant spray should an infestation be detected. Applications that require the use of powered delivery systems shall be considered Additional Work, per Exhibit C.
  3. The Director may require all Pyrus and Pyracantha species found to be infected with fireblight be treated with annual applications of a copper based dormant spray. Applications that require the use of powered delivery systems shall be considered Additional Work, per Exhibit C.
  4. The Director may require all Juniperus, Pinus, Cupressus and Pyracantha species found to be infested with mites be treated with an appropriate acaricide. Applications that require the use of powered delivery systems shall be considered Additional Work, per Exhibit C.
  5. All other insect, disease, and fungus problems will be treated on a site-and need-specific basis as determined by the Director. Any preventative or curative treatment that requires the use of powered delivery systems shall be considered Additional Work, per Exhibit C.

## E. Vertebrate Pest Control

1. All vertebrate pests, including but not limited to gophers, ground squirrels, moles, voles, and mice, shall be controlled on a regular basis wherever and whenever found on the site(s).
2. Control methods shall be as approved by the Director and shall include, but not be limited to, chemical, and mechanical methods.
3. Failure to treat site(s) for vertebrate pests within seven (7) calendar days of notification from the Director may result in the assessment of non-performance penalties, per Exhibit C.
4. Landscape areas shall be inspected and treated as necessary a minimum of one (1) time per month unless otherwise noted in the Frequency of Services Table or as determined by the Director.

## F. Turf Pesticide Usage Criteria

### 1. Weed Control

- a. When the Director determines that the turf weed population at any site(s) exceeds acceptable levels, an appropriate herbicide shall be applied in accordance with all label specifications. Treatments that require the use of powered delivery systems may be considered Additional Work, per Exhibit C.
- b. All turf areas that the Director has determined to be prone to annual weed grass intrusion shall require annual applications of pre-emergent herbicides labeled for such use. Any preventative treatment that requires the use of powered delivery systems may be considered Additional Work, per Exhibit C.
- c. Failure to apply turf weed control materials within the time frames established by the Director may result in the assessment of non-performance penalties, per Exhibit C.

### 2. Insect and Disease Control

- a. All turf areas that the Director has determined to have a history of fungus infection shall be treated annually with an appropriate fungicide, as directed. Treatments that require the use of powered delivery systems may be considered Additional Work, per Exhibit C.
- b. All other insect, disease, and fungus problems will be treated on a site and need-specific basis as determined by the Director. Any preventative or curative treatment that requires the use of powered delivery systems may be considered Additional Work, per Exhibit C.
- c. All vertebrate pests, including but not limited to gophers, ground squirrels, moles, voles, and mice, shall be controlled on a regular basis wherever, and whenever found on the site(s). Control methods shall be as approved by the Director and shall include, but are not limited to, chemical, and mechanical methods. Failure to treat site(s) for vertebrate pests, within forty-eight (48) hours of being noticed by



the Director, may result in the assessment of non-performance penalties, per Exhibit C.

#### 14. SCHEDULING OF WORK

- A. The Contractor will adhere to the facilities, equipment and monthly and annual work schedules submitted as a part of the Contractor's proposal, and incorporated herein by this reference. These schedules, and any approved revisions thereto, will be used by the City as a basis for determining Contractor's satisfactory performance.
- B. Revisions to facilities, equipment, or monthly and annual work schedules may not be implemented without the prior written approval of the Director. The Contractor is required to submit proposed revisions regarding facilities, equipment or monthly and annual work schedules in writing to the City at the address as set forth in the Agreement at least ten (10) working days prior to commencing work per the proposed revisions.
- C. The above provisions shall not be construed to eliminate the Contractor's responsibility for complying with the requirement to notify the Director for Specialty type maintenance as set forth immediately hereinafter.
- D. The Contractor shall notify the Director in writing at least five (5) working days prior to the date and time of all "Specialty" type maintenance operations. Specialty type maintenance operations includes, but is not limited to:
  - 1. Fertilization;
  - 2. Turf Aeration;
  - 3. Application of pesticides by any method;
  - 4. Other operations so designated by the Director.

Notification of "Specialty" maintenance operations shall include a brief description of intended method(s) of execution, materials to be used, and the dates for commencement and completion of said operations.

- E. When inclement weather renders performance per the approved schedule unsafe, impractical, or liable to damage landscaping, the Contractor is required to adjust his work force to accomplish those work items not affected by weather, and will contact the City field staff to inform them of said alternate work assignments.
- F. For the purposes of this agreement, "Working Days" are Mondays through Fridays, excluding holidays as provided herein. The hours of on-site maintenance service will be from 7:00 a.m. to 4:00 p.m., not including mobilization to or from work site, on those days maintenance is to be provided pursuant to the work schedule as approved by the Director. Any work the Contractor proposes to perform outside of the days and hours set forth hereinabove, as well as on legal City holidays, shall not be undertaken without the prior written approval of the Director.

The following days have been designated as City holidays:

|                            |                          |
|----------------------------|--------------------------|
| New Year’s Day             | January 1                |
| Martin Luther King Jr. Day | 3rd Monday in January    |
| President’s Day            | 3rd Monday in February   |
| Memorial Day               | Last Monday in May       |
| Independence Day           | July 4                   |
| Labor Day                  | 1st Monday in September  |
| Veteran’s Day              | November 11              |
| Thanksgiving Day           | 4th Thursday in November |
| Day after Thanksgiving     | 4th Friday in November   |
| Christmas Eve              | December 24              |
| Christmas Day              | December 25              |

If a holiday falls on a Sunday, the following Monday shall be the day the holiday is observed. If a holiday falls upon a Saturday, the preceding Friday shall be the day the holiday is observed. If a scheduled maintenance service day falls on a designated holiday, the Contractor shall submit a proposed make-up day for the Director’s approval.

**15. FUNCTIONS AND RESPONSIBILITIES**

- A. For award of the agreement to a Contractor who has not performed landscape and irrigation maintenance services for the site(s) as identified within this agreement for the prior year’s contracting term, the Director and Contractor shall conduct an inspection of all sites covered under this agreement as soon as practicable after its execution, and prior to commencement of Contractor's operations. Following said inspection, the Contractor shall submit to the Director a written affidavit certifying the actual condition of the site(s) relative to the City Specifications, including but not limited to the nature and extent of any deficiencies noted by the Contractor, and acknowledged by the Director. The Contractor is hereby advised that this affidavit shall serve as the benchmark for the Director's evaluation of Contractor's performance under this agreement.
- B. The Contractor shall on an ongoing basis maintain and submit complete reports that record all work performed by the Contractor (See Reporting Forms) and at the intervals specified therein. Such reports shall contain, but shall not be limited to Weekly Irrigation reports, Monthly Greenwaste reports, Monthly Landscape Services reports, pesticide reports, and complaints.
- C. The monthly payment for the work so reported will not be authorized until such reports are received, and approved by the Director.
- D. The Director may require the Contractor to attend meetings with the City field staff at some fixed interval to review the Contractor's operations, and schedule future work as may be ordered by the Director.

Attachment: Agreement for On-Site and/or Professional Services (3332 : APPROVE THE FIRST AMENDMENT TO THE ON-SITE AND/OR

- E. The Contractor shall maintain an office at some fixed place, and be listed in the telephone directory in Contractor's own name or in the Contractor's name.
- F. Contractor shall at all times employ some responsible person(s) to receive phone calls and take the necessary action regarding all inquiries, complaints, and/or emergency calls that may be received from the Director or other authorized individuals or agencies as listed below. This person(s) shall be reachable twenty-four (24) hours per day, seven (7) days a week. Contractor shall notify the Director at [specialdistricts@moval.org](mailto:specialdistricts@moval.org) within three (3) calendar days of any change of the name or contact information of the responsible person(s).
- G. During normal working hours, the Contractor's Supervisor or designated employee responsible for providing maintenance services to the City shall be directly available for immediate notification through some type of reliable electronic means, including but not limited to, mobile or cellular phone.
- H. The Contractor or Contractor's designated employee shall confirm said notification within one (1) hour of receipt. An answering service will be considered an acceptable substitute for coverage only during periods outside of normal working hours, provided Contractor is advised of emergency calls within one (1) hour of receipt of the call by the answering service and within twenty-four (24) hours after receipt of non-emergency calls by the answering service. The above provision for Contractor's communication with the City is the minimum acceptable standard under this agreement.
- I. The Contractor shall respond to an emergency call from any of the parties listed herein this section no later than two (2) hours following first notification by telephone, written email, written mailed correspondence or facsimile transmission. In situations involving emergency repair work after normal working hours, the Contractor shall dispatch qualified personnel, and equipment to reach the site within two (2) hours of first notification. An emergency may be called by the following individuals or agencies at any time:
- |  |                                       |
|--|---------------------------------------|
| 1. City Manager/Assistant City Manager | 5. Special Districts Division Manager |
| 2. Public Works Director               | 6. Street Maintenance Supervisor      |
| 3. Police Department                   | 7. Landscape Services Supervisor      |
| 4. Fire Department                     | 8. Landscape Services Inspector       |
- J. Contractor's emergency response and any necessary corrective work shall be considered Additional Work as defined in Exhibit C, unless said emergency is determined to have been caused by an act or omission attributable to the Contractor.

## 16. COMPLAINTS

- A. All complaints shall be responded to as soon as possible after notification, but in all cases within twenty-four (24) hours, to the satisfaction of the Director. If any complaint is not satisfactorily responded to within twenty-four (24) hours, the Director shall be notified immediately of the reason for not remedying the

complaint followed by a written report to the Director within five (5) working days. If the complaints are not remedied within the time specified, and to the satisfaction of the Director, the Director may correct the specific complaint by using an alternative source. The total cost incurred by the District to effect necessary remedies will be deducted from the payments owing to the Contractor from the City, per Exhibit C.

- B. The Contractor shall maintain a written record of all complaints, the date and time thereof, and the action taken pursuant thereto, or the reason for non-action. Said record shall be submitted to the Director monthly, as part of the Monthly Landscape Services Report.
- C. In addition to the provisions included herein, in the event of a failure by the Contractor to satisfactorily remedy a complaint in a timely manner or for any other breach of this agreement by Contractor, the City may immediately, upon written notice to the Contractor, terminate this agreement.

## 17. CONTRACTOR'S STAFF

- A. The Contractor shall provide sufficient personnel to perform all work in accordance with the Specifications set forth herein. All of the Contractor's maintenance personnel shall be supervised at the work site(s) by a qualified Supervisor in the employ of the Contractor. Work Site Supervisors must be able to demonstrate to the satisfaction of the Director that they possess adequate technical background, and communication skills to perform the intended services. Adequate and competent supervision shall be provided for all work done by the Contractor's employees to ensure accomplishment of high quality work, which will be acceptable to the Director. Any order or communication given to the Work Site Supervisor shall be deemed to have been delivered to the Contractor.
- B. The Contractor and his employees and subcontractors, if any, shall conduct themselves in a proper, professional, and efficient manner at all times, and shall cause the least possible inconvenience to the public.
- C. The Director may require the Contractor to remove from the work site any employee(s) deemed careless, incompetent, or otherwise objectionable, whose continued employment on the job is considered to be contrary to the best interests of the City.
- D. The Contractor shall require each employee performing work under the agreement to adhere to basic public works standards of working attire, including but not limited to wearing of proper clothing, proper shoes, and other gear required by applicable Safety Regulations and/or fertilizer/pesticide label requirements.
- E. Shirts shall be worn at all times, and shall be buttoned. Approved safety vests shall be worn by Contractor's employees when working on parkway medians,

monuments, parkways, and other high traffic-hazard areas as determined by the Director.

- F. The Contractor shall establish an identification system for Contractor's personnel which clearly indicates to the public the name of the Contractor. The identification system shall be furnished at the Contractor's expense and may include appropriate attire, and/or name badges as specified by the Director.

## 18. EMPLOYMENT OF APPRENTICES

- A. The provisions of Sections 1777.5, 1777.6, and 1777.7 of the California Labor Code regarding the employment of properly registered apprentices may apply to this agreement if the Contractor, or any subcontractors thereunder, employs workers in any apprenticeable craft or trade. It is the Contractor's sole responsibility to comply with the Labor Code sections cited above. Information relative to apprenticeship standards, wage schedules, and other requirements may be obtained from the California Department of Industrial Relations.

## 19. SAFETY

- A. The Contractor agrees to perform all work as outlined in the provisions listed herein in such a manner as to meet all accepted standards for safe practices and to safely maintain equipment, machines, and materials, and prescribe and employ all precautions and safety procedures related to other hazards consequential to the work; and accepts additionally the sole responsibility for complying with all local, State, Federal and other legal requirements including but not limited to, full compliance with the terms of any and all applicable OSHA and Cal/OSHA Safety Orders at all times so as to protect all persons, including Contractor's employees and subcontractors, agents of the City, District, materialmen, vendors, members of the public and others from foreseeable injury, or damage to their property.
- B. The Contractor's operations shall be conducted in such a manner as to cause the least possible obstruction, and inconvenience to public traffic. The Contractor shall furnish, erect and maintain such fences, barriers, lights and warning signs as may be deemed necessary by the Director, or any duly constituted public safety official.
- C. Contractor's work area traffic control, including but not limited to, type and placement of signs, barricades, and delineators, shall be in accordance with the "Manual of Uniform Traffic Control Devices, 2012 (or most current revised version) California Supplement" Part 6 Temporary Traffic Control.
- D. Contractor's work should not encroach into open lanes of traffic between the hours of 7:00 a.m. and 8:30 a.m., or between the hours of 3:30 p.m. and 6:00 p.m.

- E. The Contractor shall maintain all work sites free of hazards to persons or property resulting from Contractor's operations. The Contractor shall inspect for all potential hazards at said areas under maintenance, and keep a record indicating date inspected, and action taken. Said record shall be submitted to the Director monthly as part of the Monthly Landscape Services Report. Any hazardous condition noted by the Contractor, which is not a result of Contractor's operations, shall be immediately reported to the Director.
- F. The Contractor shall be responsible for making minor corrections, including but not limited to, filling holes in turf areas, replacing valve box covers, and repairing irrigation systems, so as to protect members of the public or others from injury.
- G. The Contractor shall cooperate fully with the City in the investigation of any accidental injury or death occurring on the site, including a complete written report thereof to the Director within five (5) working days following the occurrence.
- H. In addition to payment deduction or assessment of non-performance penalties, repeated failure to comply with the provisions of this section may result in termination of the agreement, per the terms of the Independent Contractor Agreement.

## 20. USE OF CHEMICALS

- A. Before the beginning of the agreement period, the Contractor is required to submit a list, which shall include the exact Brand Name, Label, and Material Safety and Data Sheet (MSDS) of all chemicals proposed for use under this agreement, including but not limited to fertilizers and pesticides, for approval by the Director. Where applicable, materials included on this list shall be chemicals as approved by the State of California Department of Food and Agriculture.
- B. Director shall be notified in writing of any changes or deviations from the above list. Use or application of said materials shall not be made prior to approval by the Director.
- C. Chemical applications, including but not limited to fertilizers and pesticides, shall be made in strict compliance with the label directions, restrictions, and precautions as well as with any other requirements deemed necessary by any county, state, or federal regulatory agency, or the Public Works Department of the City of Moreno Valley.
- D. Contractor shall report all fertilizers and pesticides used in the performance of the work as an element of Contractor's Monthly Landscape Services report, as set forth herein. This report shall include the date, time of day, location, type of material, method of application, and environmental data.
- E. The Contractor is free to use the most cost-effective pesticide available that has a California approved label and is used in compliance with this label. The

City is sensitive to the need to use the least toxic material available that will be effective. In practice that may mean products that carry the CAUTION signal word would be the material of choice.

In the event the City opts to reduce the use of 'synthetic' pesticides in favor of alternative, naturally derived materials or methods, the Contractor will end the use of synthetic materials (e.g. glyphosate) and implement a supplemental weed control strategy. This WILL NOT replace the weed control component already in the bidder's base cost; this will be an additional cost added to the base work amount to cover additional labor and materials that will be needed in the event use of glyphosate or other synthetic materials were to be eliminated by the City – **Alternative Bid Item.**

## **21. NATIONAL POLLUTANT DISCHARGE ELIMINATION SYSTEM (NPDES) PERMIT – REQUIRED URBAN RUNOFF MANAGEMENT TRAINING**

- A. The Contractor shall provide NPDES Permit training for Urban Runoff Management to Contractor's employees and subcontractors if any.
- B. Failure to provide Urban Runoff Management training is a violation of Order No. R8-2002-0011, NPDES No. CAS 618033 (Municipal Separate Storm Sewer System NPDES Permit), Section XI.I, for each day of which such failure occurs, and shall in addition, be a breach of the agreement with the City of Moreno Valley and/or the City of Moreno Valley Community Services District ("City").
- C. Contractor understands and agrees that NPDES Permit violations are grounds for enforcement action by the Environmental Protection Agency, the State/Regional Water Resources Control Board, and the City and may result in permit termination (stop work order), civil and criminal fines, and termination of agreement.
- D. By submitting a proposal, the Contractor certifies to the City that Contractor's employees and subcontractors, if any, have been trained for Urban Runoff Management, and sufficient sums are included in the Proposal's amount to cover costs of such said training.

## **22. RESTRICTED PESTICIDE MATERIALS PERMIT AND USE CONSENT**

- A. The City shall maintain in full force and effect throughout the entire term of the agreement a valid Restricted Materials Permit issued by the Agricultural Commissioner of the County of Riverside on behalf of the California Department of Pesticide Regulation. The Contractor shall comply with all permit conditions that pertain to any of the pest control materials listed on said permit that may be used in the course of Contractor's operations under this agreement.
- B. Director must give consent in writing prior to application of any Category I pesticide Licenses and Permits

## 23. LICENSES AND PERMITS

- A. The Contractor shall, without additional expense to the City, possess all federal, state, and local licenses and permits, including but not limited to a valid City Business License, required for the performance of the work under this agreement.

## 24. DEPARTMENT OF INDUSTRIAL REGULATIONS

- A. California law provides that "A contractor or subcontractor shall not be qualified to bid on, be listed in a bid proposal, subject to the requirements of Section 4104 of the Public Contract Code, or engage in the performance of any contract for public work, as defined in this chapter, unless currently registered and qualified to perform work pursuant to Labor Code Section 1725.5." Please refer to "Contractor Registration" from <http://www.dir.ca.gov/PublicWorks/PublicWorks.html> to register and obtain more information.
- B. Contractor and all tiers of its subcontractors must be registered and maintain a current registration during the term of this agreement.
- C. Pursuant to the above law, no contractor or subcontractor may be listed on a bid proposal for a public works project unless registered with the Department of Industrial Relations pursuant to Labor Code Section 1725.5 [with limited exceptions from this requirement for bid purposes only under Labor Code Section 1771.1(a)]. Additionally, no contractor or subcontractor may be awarded a contract for public work on a public works project (awarded on or after April 1, 2015) unless registered with the Department of Industrial Relations pursuant to Labor Code Section 1725.5.
- D. This project is also subject to compliance monitoring and enforcement by the Department of Industrial Relations. The City of Moreno Valley will not accept a proposal nor will it contract or subcontract without proof of the contractor or subcontractor's current registration to perform public works pursuant to Section 1725.5.
- E. Contractor acknowledges and agrees to fully comply with the provisions of Section 1771, 1774 - 1776, 1777.5, 1813, 1815 and 1860 of the Labor Code

## 25. PAYROLL RECORDS

- A. The Contractor, and any subcontractor thereunder, shall keep complete accurate payroll records for each workman employed by Contractor/ subcontractor in connection with this agreement, as required by California Labor Code Section 1776.
- B. The Contractor, and any subcontractor thereunder, shall make available to the City upon its request certified payroll records for each workman employed in connection with this agreement as required by California Labor Code Section 1776.



- C. The City may withhold from Contractor's progress payments the penal sum of twenty-five dollars (\$25.00) per calendar day (or portion thereof) for each worker employed in connection with this agreement should Contractor, or any subcontractors thereunder, fail to strictly comply with California Labor Code 1776 after receiving written notice of non-compliance.

## 26. PREVAILING WAGE AND WORKERS' COMPENSATION

- A. Pursuant to provision of Section 1773 of the Labor Code of the State of California, the City of Moreno Valley has obtained the general prevailing rate of per diem wages applicable for the work to be done, including but not limited to: straight time, overtime and holiday work; travel and subsistence payments; employee payments of health and welfare, vacation, pension, and similar purposes. Said rate and scale are on file with the Public Works Department of the City of Moreno Valley, and copies will be made available to any interested party on request. These rates shall be the minimum wage rates for this project. Throughout the term of this agreement, the Contractor will be required to post a copy of said rate, and scale as required by the Labor Code.
- B. Pursuant to provisions of Section 1775 of the Labor Code, the Contractor shall forfeit as penalty to the City of Moreno Valley, not more than fifty dollars (\$50.00) for each laborer, workman, or mechanic employed for each calendar day or portion thereof, if such laborer, workman, or mechanic is paid less than the general prevailing rate of wages hereinabove stipulated for any work done under the attached agreement, by the Contractor or by any subcontractor under Contractor's direction and control, in violation of the provisions of said Labor Code.
- C. In accordance with the provisions of Section 3700 of the Labor Code, every contractor will be required to secure the payment of compensation to his employees.

## 27. BONDS

- A. Pursuant to Section 3247 of the Civil Code, the Contractor hereby agrees to provide and maintain in full force and effect for the duration of this agreement, three (3) good, and sufficient surety bonds, to wit:
1. A "Bid Bond" in the amount of ten percent (10%) of the proposed bid price, which shall guarantee the compliance with the bid contract and ensure the contractor will enter into the contract if it is awarded, and;
  2. A "Faithful Performance Bond" in the amount of one hundred percent (100%) of the agreement price, which shall guarantee the faithful performance of all work, and;
  3. A "Materials and Labor Bond" in the amount of one hundred percent (100%) of the agreement price, which shall secure the payment of the claims of labor, mechanics or materialmen for all work performed hereunder.

- B. If the successful bidder neglects or refuses to enter into the agreement, or to provide the supplies, materials or equipment according to specifications within the required time, then the amount of the bidder's security shall be declared forfeited to the city. Amounts collected shall be paid into the appropriate fund. All bonds forfeited shall be prosecuted and the amount thereof collected and paid into such fund.
- C. All bids not submitted with the requested bidder's security shall be rejected. Unsuccessful bidders shall be entitled to the return of security when such has been requested.
- D. Surety Bonds shall be made payable to the City and in one of the following forms:
  1. Certified or cashier's check;
  2. Bidders bond made payable to the City. Bond to be executed by a corporate surety authorized to engage in such business in California, and listed in the U.S. Department of Treasury's listing of approved sureties;
  3. Cash (U.S. funds only). (Ord. 844 § 2, 2012)

## 28. SUBSTITUTION OF SECURITIES

- A. Pursuant to California Public Contract Code Section 22300, the Contractor will be permitted the substitution of securities for any monies withheld by the City of Moreno Valley to ensure performance under the agreement. At the request and expense of the Contractor, securities equivalent to the amount withheld shall be deposited with the City of Moreno Valley, or with a state or federally chartered bank as the escrow agent, who shall pay such monies to the Contractor.
- B. Securities eligible for substitution under this section shall include those listed in Section 16430 of the Government Code, bank or savings and loan certificates of deposit, interest-bearing demand deposit accounts, and standby letters of credit. The Contractor shall be the beneficial owner of any securities substituted for monies withheld, and shall receive any dividends or interest thereon.
- C. The Contractor shall give the City written notice within thirty (30) days after the agreement is awarded that it desires to substitute securities for money that would ordinarily be withheld. If the substituted securities are deposited into an escrow, the escrow shall be governed by a written escrow agreement in a form which is substantially similar to the agreement set forth in Section 22300 of the Public Contract Code.

## 29. CONTRACTOR'S LIABILITY

- A. The Contractor shall be responsible for all damages to people and/or property that occur as a result of the fault or negligence attributable to the Contractor in connection with the performance under this agreement. Any and all restitution

or repairs deemed necessary by the Director to remedy such damages shall be furnished and performed at the Contractor's sole expense, and shall be completed within the time limits established by the Director.

### 30. CONTRACTORS LICENSE

- A. Contractors are required by law to be licensed, and regulated by the Contractors' State License Board. Contractor will comply with all applicable licensing laws, and regulations. Any questions concerning a Contractor may be referred to the Registrar, Contractors' State License Board, 9821 Business Park Drive, Sacramento, CA 95827. Mailing address: P.O. Box 26000, Sacramento, CA 95826.

### 31. CLAIM RESOLUTION PROCEDURES

Section 9204 of the Public Contract Code sets forth the following requirements for claims submitted by a contractor on a public works project:

- A. A contractor must furnish "reasonable documentation to support the claim."
- B. Upon receipt of a claim, a public entity must "conduct a reasonable review" and provide a written statement to the contractor within 45 days of receipt of the claim.
- C. For any undisputed portion of a claim, a public entity must make payment within 60 days of the public entity's issuance of the written statement.
- D. If the contractor disputes the public entity's written statement, or if the public entity fails to respond, the contractor may demand "an informal conference to meet and confer for settlement of the issues in dispute."
- E. The public entity must schedule the meet and confer conference within 30 days of the demand.
- F. Within 10 business days following the meet and confer conference, the public entity must provide a written statement identifying the portion of the claim that remains in dispute. Any payment due on an undisputed portion of the claim must be made within 60 days of the meet and confer conference.
- G. After the meet and confer conference, any disputed portion of the claim "shall be submitted to non-binding mediation."
- H. If mediation is unsuccessful, the parts of the claim that remain in dispute shall be subject to applicable procedures outside Section 9204 (statutory and contractual).
- I. Failure of a public entity to respond to a claim within the time periods described in Section 9204 "shall result in the claim being deemed rejected in its entirety."
- J. Amounts not paid in a timely manner shall bear interest at 7 percent per year.

32. PROJECT LOCATION MAP



Attachment: Agreement for On-Site and/or Professional Services (3332) : APPROVE THE FIRST AMENDMENT TO THE ON-SITE AND/OR

### 33. REPORTING FORMS

- A. Weekly Irrigation reports, at a minimum, shall document the irrigation inspections (to include testing and repairs) performed by the Contractor and shall include details specific to the dates, the specific locations, and corrective action taken, if any. Weekly Irrigation reports shall be submitted to the Director at [specialdistricts@moval.org](mailto:specialdistricts@moval.org) by the second workday of the week, one (1) week in arrears.
- B. Greenwaste Recycling
1. The Public Resources Code (PRC), Division 30, Sections 41000 through 41780 requires that the City of Moreno Valley divert from landfills fifty percent (50%) of the solid waste, including greenwaste, generated within its jurisdiction.
  2. For the purposes of this agreement, materials defined as “greenwaste” shall include all plant parts (i.e. trimmings, prunings, grass clippings, etc.) removed from agreement sites by the Contractor, or any subcontractors thereunder, in the performance of agreement’s Scope of Work.
  3. Contractor, or any subcontractor thereunder, shall deposit all greenwaste generated while performing the agreement’s Scope of Work at a landscape material recycling center, or reuse said greenwaste in a lawful manner. Contractor, or any subcontractor thereunder, shall be solely responsible for all costs incurred in complying with this requirement.
  4. The Contractor shall submit a Monthly Greenwaste Report as set forth herein. The Contractor shall provide responses to all information requested therein and shall include, on a separate Monthly Greenwaste Report form, any greenwaste generated through the operations of any subcontractors performing work under Contractor’s Scope of Work.
  5. Monthly Greenwaste reports shall be submitted to the Director at [specialdistricts@moval.org](mailto:specialdistricts@moval.org) by the tenth day of each month, one (1) month in arrears.
- C. A Monthly Landscape Services report, at a minimum, shall document the work performed by the Contractor and shall contain detailed information as is described in the form attached hereto and any other relevant information about the Contractor’s work to identified hazards, chemical use, and customer complaints. Said report shall be in a format acceptable to the Director. Monthly Landscape Services reports shall be submitted to the Director at [specialdistricts@moval.org](mailto:specialdistricts@moval.org) by the tenth day of each month, one (1) month in arrears.
- D. Pesticide Use reports shall be completed and submitted in accordance with federal, state, and local law and consistent with the provisions herein.
- E. Contractor shall refer to sections included herein and ensure additional reports, if necessary, are submitted to the Director, as appropriate and consistent with this

agreement, and other agencies, as required by law, to ensure compliance with all federal, state, and local laws.

**Attachment: Agreement for On-Site and/or Professional Services (3332 : APPROVE THE FIRST AMENDMENT TO THE ON-SITE AND/OR**

### Weekly Irrigation Report Form

City of Moreno Valley, Special Districts Division  
[specialdistricts@moval.org](mailto:specialdistricts@moval.org) – Due: 2<sup>nd</sup> workday of week, 1 week in arrears

PROJECT NO. \_\_\_\_\_

MONTH OF \_\_\_\_\_, 20\_\_\_\_\_

|               | <b>Location</b> <ul style="list-style-type: none"> <li>• Controller Number</li> <li>• Tract Number</li> <li>• Zone or Area</li> </ul> | <b>Date(s) Checked</b> | <b>Problem(s) Identified</b> | <b>Corrective Actions</b> <ul style="list-style-type: none"> <li>• Date corrected</li> <li>• Corrective action details</li> </ul> | <b>Hazards</b> <ul style="list-style-type: none"> <li>• Date(s) noted</li> <li>• Area</li> <li>• Hazard type</li> <li>• Date City notified</li> <li>• Date corrected</li> </ul> |
|---------------|---|------------------------|------------------------------|---|---|
| <b>WEEK 1</b> |   |                        |                              |   |   |
| <b>WEEK 2</b> |   |                        |                              |   |   |
| <b>WEEK 3</b> |   |                        |                              |   |   |
| <b>WEEK 4</b> |   |                        |                              |   |   |
| <b>WEEK 5</b> |   |                        |                              |   |   |

Attachment: Agreement for On-Site and/or Professional Services (3332 : APPROVE THE FIRST

### Monthly Greenwaste Report Form

City of Moreno Valley, Special Districts Division  
[specialdistricts@moval.org](mailto:specialdistricts@moval.org) – Due: 10<sup>th</sup> day of each month, 1 month in arrears

**PROJECT NO. 2017-027**

**Month** \_\_\_\_\_ **Year** \_\_\_\_\_

1. Source of greenwaste  
     Location \_\_\_\_\_
2. Amount of greenwaste generated from above source (by weight) \_\_\_\_\_ Lbs. or tons
3. Name, address, and phone number of recycle Contractor accepting greenwaste  
     Contractor Name \_\_\_\_\_  
     Address \_\_\_\_\_  
     Phone Number \_\_\_\_\_
4. Amount of greenwaste-source products (mulch, compost, top dressing, and soil amendments, etc.) furnished to Project (by weight) \_\_\_\_\_ Lbs. or tons
5. Name, address, and phone number of recycle Contractor supplying greenwaste-source products to Project (if different from above)  
     Contractor Name \_\_\_\_\_  
     Address \_\_\_\_\_  
     Phone Number \_\_\_\_\_
6. Number of times turf mowed this month \_\_\_\_\_
7. Number of times turf mowed without clippings caught \_\_\_\_\_

**Contractor Name:** \_\_\_\_\_

**Address:** \_\_\_\_\_

**Phone Number:** \_\_\_\_\_

Attachment: Agreement for On-Site and/or Professional Services (3332 : APPROVE THE FIRST AMENDMENT TO THE ON-SITE AND/OR



## Monthly Landscape Services Report Form

City of Moreno Valley, Special Districts Division  
[specialdistricts@moval.org](mailto:specialdistricts@moval.org) – Due: 10<sup>th</sup> day of each month, 1 month in arrears

PROJECT NO. \_\_\_\_\_ MONTH OF \_\_\_\_\_, 20\_\_

|        | <b>Location</b> <ul style="list-style-type: none"> <li>• Controller Number</li> <li>• Tract Number</li> <li>• Zone or Area</li> </ul> | <b>Maintenance</b> <ul style="list-style-type: none"> <li>• Date(s)</li> <li>• Area</li> </ul> <b>Service Type</b> <ul style="list-style-type: none"> <li>• Mow/edge</li> <li>• Trim/prune-weed</li> <li>• Litter-irrigation</li> <li>• Etc.</li> </ul> | <b>Fertilizer</b> <ul style="list-style-type: none"> <li>• Date(s)</li> <li>• Area</li> <li>• Product/analysis</li> <li>• Amount/area</li> <li>• Crop</li> </ul> | <b>Pesticides</b> <ul style="list-style-type: none"> <li>• Date(s)</li> <li>• Product used</li> <li>• Amount used</li> <li>• Area</li> <li>• Target pest</li> </ul> | <b>Complaints</b> <ul style="list-style-type: none"> <li>• Date(s) received</li> <li>• Area/location</li> <li>• Complaint/action</li> <li>• Date corrected</li> <li>• Corrective action</li> </ul> | <b>Hazards</b> <ul style="list-style-type: none"> <li>• Date(s) noted</li> <li>• Area</li> <li>• Hazard type</li> <li>• MVCSD notified</li> <li>• Date City notified</li> <li>• Date corrected</li> <li>• Corrective action</li> </ul> |
|--------|---|---|--|---|--|--|
| WEEK 1 |   |   |  |   |  |  |
| WEEK 2 |   |   |  |   |  |  |
| WEEK 3 |   |   |  |   |  |  |
| WEEK 4 |   |   |  |   |  |  |
| WEEK 5 |   |   |  |   |  |  |

Attachment: Agreement for On-Site and/or Professional Services (3332 : APPROVE THE FIRST

## **EXHIBIT B - CITY RESPONSIBILITIES**

**RFP NO. 2018-014**

LANDSCAPE MAINTENANCE – ZONE 02  
Maintenance of Parkway, Median, and Open space  
Landscaping and Irrigation

### **1. AGREEMENT SUPERVISION**

The Agreement shall be administered on behalf of the Financial and Management Services Director of the City of Moreno Valley, or his/her delegated representative(s), hereinafter designated as "Director."

The Director will decide all questions which may arise as to the manner of performance and completion per schedule, acceptable fulfillment of the Contract by the Contractor, interpretation of the Specifications, and compensation to include completion of work by alternate sources.

### **2. IRRIGATION CONTROLLER SYSTEMS**

The City shall manage the operation of all automatically controlled irrigation systems, including but not limited to irrigation controller programming and scheduling. The Contractor shall monitor the operation of, and maintain said irrigation systems as required by the Director. The Contractor shall operate manually controlled irrigation systems as directed by City field staff.

### **3. UTILITIES**

It shall be the City's duty to provide the utilities necessary for irrigation (i.e., water, electricity and communications) and to maintain their appurtenances (i.e., water and electrical meters and backflow devices). The City will pay the water, electricity, and communications costs used in the sites covered by this Agreement. The Contractor shall report any interruption of these services for whatever reason immediately upon Contractor's observation of same to the Director.

### **4. RESTRICTED PESTICIDE MATERIALS/PERMIT/USE CONSENT**

- A. The City shall maintain in full force and effect throughout the entire term of the Contract a valid Restricted materials Permit issued by the Agricultural Commissioner of the County of Riverside on behalf of the California Department of Pesticide Regulation. The Contractor shall comply with all permit conditions that pertain to any of the pest control materials listed on said permit that may be used in the course of Contractor's operations under this Contract.
- B. Director must give consent in writing prior to application of any Category I pesticide.

## EXHIBIT C - PAYMENT TERMS

### RFP NO. 2018-014

LANDSCAPE MAINTENANCE – ZONE 02  
Maintenance of Parkway, Median, and Open space  
Landscaping and Irrigation

#### 1. CONTRACTORS COMPENSATION

- A. The Contractor's compensation shall not exceed \$1,334,200.00.
- B. Except where additional compensation is specifically provided for in this Agreement, the City will pay the Contractor for all work (labor, material, supplies, equipment, etc.) performed under this Agreement for fiscal year 2018/19 the total amount of Two Hundred Thirty-Six Thousand and 00/100 Dollars (\$236,000.00) per month, one (1) month in arrears, on the last day of the month. The total Agreement amount for twelve (12) months shall not exceed Nine Thousand, Four Hundred Twenty-Eight and 00/100 Dollars (\$9,428.00), except as provided for herein Exhibit C, Section 2 below.
- C. The Contractor will obtain, and keep current during the term of this Agreement, the required City of Moreno Valley business license. Proof of a current City of Moreno Valley business license will be required prior to any payments by the City. Any invoice not paid because the proof of a current City of Moreno Valley business license has not been provided will not incur any fees, late charges, or other penalties. Complete instructions for obtaining a City of Moreno Valley business license are located at: [http://www.moval.org/do\\_biz/biz-license.shtml](http://www.moval.org/do_biz/biz-license.shtml)
- D. The Contractor will electronically submit an invoice to be paid monthly per site based upon successful performance of the maintenance services provided in accordance with an approved service schedule for each area/site and in compliance with the terms and provisions of this Agreement. By the tenth of each month the Contractor shall submit to the Director detailed reports of the following:
  - a. Maintenance performed, which must include the location, area or site of such maintenance.
  - b. Greenwaste.
  - c. Complaints received.
  - d. Hazards noted.
  - e. Chemicals used in the prior month.
  - f. Invoice for service, which lists in detail the site, service performed and cost in accordance with the Agreement price, which shall become the basis for payment.

No payment(s) shall be made until the reports, listed herein, have been submitted and approved. At no time will the City pay for more services than have been satisfactorily completed and the City's determination of the amount due shall be final.

- E. The Contractor will submit all invoices electronically to Accounts Payable staff at [accountspayable@moval.org](mailto:accountspayable@moval.org). Accounts Payable questions can be directed to 951.413.3073.

The Contractor will electronically submit copies of invoices and reports to the Special Districts Division at [specialdistricts@moval.org](mailto:specialdistricts@moval.org). Calls may also be directed to the Special Districts Division at 951.413.3480.

- F. The Contractor agrees that City payments will be received via Automated Clearing House (ACH) Direct Deposit and that the required ACH Authorization form will be completed prior to any payments by the City. Any invoice not paid because the completed ACH Authorization Form has not been provided will not incur any fees, late charges, or other penalties. The ACH Authorization Form is located at: [http://www.moval.org/city\\_hall/forms.shtml#bf](http://www.moval.org/city_hall/forms.shtml#bf)

- G. The minimum information required on all invoices is:

- a. Vendor Name, Mailing Address, and Phone Number
- b. Invoice Date
- c. Vendor Invoice Number
- d. City-provided Reference Number (e.g. Project, Activity, Median ID, Tract ID/#, etc.)
- e. Detailed work hours by class title (e.g. Manager, Technician, or Specialist), services performed and rates, explicit portion of an Agreement amount, or detailed billing information that is sufficient to justify the invoice amount; single, lump amounts without detail are not acceptable.

- H. The City shall pay the Contractor for all invoiced, authorized professional services within thirty (30) days of receipt of the invoice for same.

- I. Reimbursement for Expenses. Contractor shall not be reimbursed for any expenses unless authorized in writing by City.

- J. Maintenance and Inspection. Contractor shall maintain complete and accurate records with respect to all costs and expenses incurred under this Agreement. All such records shall be clearly identifiable. Contractor shall allow a representative of City during normal business hours to examine, audit, and make transcripts or copies of such records and any other documents created pursuant to this Agreement. Contractor shall allow inspection of all work, data, documents, proceedings, and activities related to the Agreement for a period of three (3) years from the date of final payment under this Agreement.

## 2. ADDITIONAL WORK

- A. During the term of this Agreement the City may, at its discretion, authorize the Contractor to perform certain Additional Work as included in Exhibit E, herein, in addition to the work set forth in Exhibit A.
- B. If the City determines it to be in the City's best interest, said Additional work may include: Acts of God (i.e., earthquake damage, storm damage), or vandalism, theft, and acts or omissions by third parties.
- C. Compensation for all such Additional Work shall be calculated either: at the prices set forth by the Contractor in Exhibit E or at a price based on the Contractor's written estimate (lump sum, time and materials, or cost plus basis), as determined by the Director. Except as set forth below, the Contractor shall not perform any such Additional Work without first obtaining express written authorization from the City.
- D. Notwithstanding the above requirement for prior written authorization, when a condition exists wherein there is imminent danger of injury to the public or damage to property, the City may verbally authorize the work to be performed upon receiving a verbal estimate from the Contractor. Within twenty-four (24) hours after receiving a verbal authorization, the Contractor must submit a written estimate to the City for written approval. Whenever immediate action is required to prevent impending injury, death, or property damage to the facilities being maintained, the City may, after reasonable attempt to notify the Contractor, cause such action to be taken by the City's work force.
- E. The Contractor shall maintain as Additional Work, at a unit price comparable to landscape areas described herein, additional landscape areas that the City may add to this Agreement. In the event that notification is made, at other than the beginning of a monthly period, the unit cost as set forth by Contractor in Exhibit E shall be prorated from the day the Contractor commences work on the additional areas.
- F. Routine repairs to project irrigation system(s) shall be considered Additional Work to the extent that the Contractor shall charge only for materials used to perform said repairs at Contractor's cost plus a percentage of that cost, as set forth in Exhibit E. For the purposes of this Agreement, routine irrigation repairs are defined as repair and/or replacement of existing sprinklers, sprinkler components, and/or non-pressurized pipe, and/or fittings ("lateral lines") that have been rendered inoperable due to: a) normal "wear and tear", and b) vandalism or theft (which includes acts or omissions by third parties).
- G. Except as specifically approved by subsequent action of the City Council and/or District Board of Directors, the Director may not authorize Additional Work in excess of One Hundred Twenty-Two Thousand, Eight Hundred Sixty-Four and 00/100 Dollars (\$122,864.00) for fiscal year 2018/19.

### 3. PAYMENT DEDUCTIONS

The City may deduct payment to such extent as may be necessary to protect the City from loss due to:

- A. Work required in the General or Technical Provisions which is: not performed, not performed to the standards set forth therein, not performed at or within the time(s) specified therein, or is incomplete.
- B. Claims filed or reasonable evidence indicating probable filing of claims by laborers, materialmen, subcontractors, or third parties.

### 4. NON-PERFORMANCE PENALTIES

- A. The Contractor may become liable for payment of non-performance penalties for failure to: provide adequate communications; provide adequate work area safety; complete "Specialty" operations in a timely manner as set forth in the General Provisions; submit notifications or reports required by the Agreement, or General Provisions at the intervals and/or frequencies set forth therein, or; perform work as required by the General Provisions at the intervals and/or frequencies as set forth therein, or as set forth in Contractor's approved work schedule, or as directed by the City. For each of the categories set forth hereinabove, the penal sum of \$100.00 (one hundred dollars) per working day will be assessed for each working day the deficiencies remain uncorrected.
- B. If non-performance penalties are to be assessed, the Contractor will be notified immediately by written email, facsimile transmission, letter, or by telephone.
- C. The Contractor will not be assessed non-performance penalties for delays caused by the City or by the owner of a utility to provide for the removal or relocation of utility facilities.
- D. Excessive Utility Usage. Contractor shall pay for all excessive utility usage due to Contractor's failure to monitor irrigation system malfunctions or unauthorized increases in the frequency of irrigation. The excess cost will be determined by comparing the current usage with the historical usage for the same time period. The excess cost factor, to be deducted from the payments to the Contractor, will be presented by the Director to the Contractor prior to actual deduction by the City to allow for explanations.

**5. COMPENSATION DETAIL**

| FY 2018/19 Landscape Maintenance Service Schedule |                        |                  |                    |                      |                              |                      |
|---|------------------------|------------------|--------------------|----------------------|------------------------------|----------------------|
| Service Area                                      | Base Work <sup>1</sup> |                  |                    |                      | Additional Work <sup>2</sup> | Total                |
|   | Service Level          | Est. Sq Ft.      | Monthly Cost       | Annual Cost          |                              |                      |
| Zone 02 Parkways & Median                         | Level 1                | 265,280          | \$ 5,508.00        | \$ 66,096.00         | \$ 122,864.00                | \$ 236,000.00        |
| Zone 02 Paseos                                    | Level 1                | 3,308,892        | \$ 3,920.00        | \$ 47,040.00         |                              |                      |
| <b>Subtotal</b>                                   |                        | <b>3,574,172</b> | <b>\$ 9,428.00</b> | <b>\$ 113,136.00</b> | <b>\$ 122,864.00</b>         | <b>\$ 236,000.00</b> |

1 Base Work is routine maintenance at a regular frequency (i.e. service level). Parkway & Median - Level 1 = 4 week rotation; Level 2 = 8 week rotation; Level 3 = 12 week rotation. See Exhibit E, Schedule II - Frequency of Services Table for additional information.  
Paseos - Divided into 6 maintenance areas. Each area receives shrub trimming, trail and fence clearing, and clearance of a 24' width of open space abutting residential parcels.  
Level 1 = Monthly (1 maintenance area per month, 6 month rotation) + 1 annual weed abatement  
Level 2 = Every Other Month (1 maintenance area every other month, 12 month rotation) + 1 annual weed abatement  
Level 3 = Quarterly (1 maintenance area every quarter, 18 month rotation) + 1 annual weed abatement  
Level 4 = Annually (annual clearance of 24' width only, no shrub trimming or trail/fence clearing)

2 Additional Work is for unanticipated/emergency work and reinvestments. The amounts are based on an area's financial resources to support work beyond routine maintenance, may vary in any given year and are contingent upon budget approvals.

**6. PREVAILING WAGE DETERMINATION**

A. Based on information available at time of RFP issuance. See tables on following pages.

Attachment: Agreement for On-Site and/or Professional Services (3332 : APPROVE THE FIRST AMENDMENT TO THE ON-SITE AND/OR

GENERAL PREVAILING WAGE DETERMINATION MADE BY THE DIRECTOR OF INDUSTRIAL RELATIONS  
PURSUANT TO CALIFORNIA LABOR CODE PART 7, CHAPTER 1, ARTICLE 2, SECTIONS 1770, 1773 AND 1773.1

**CRAFT: ## LANDSCAPE MAINTENANCE LABORER**

(APPLIES ONLY TO ROUTINE LANDSCAPE MAINTENANCE WORK NOT NEW LANDSCAPE CONSTRUCTION)<sup>1</sup>

**DETERMINATION:** SC-LML-2017-1

**ISSUE DATE:** February 22, 2017

**EXPIRATION DATE OF DETERMINATION:** March 31, 2017\* Effective until superseded by a new determination issued by the Director of Industrial Relations. Contact the Office of the Director – Research Unit at (415) 703-4774 for the new rates after 10 days from the expiration date, if no subsequent determination is issued.

| LOCALITY:                     | Employer Payments |                    |         |                    |         |          | Straight-Time |                     | Overtime            |      |
|-------------------------------|-------------------|--------------------|---------|--------------------|---------|----------|---------------|---------------------|---------------------|------|
|                               | Basic Hourly Rate | Health and Welfare | Pension | Vacation           | Holiday | Training | Hours         | Total Hourly Rate   | 1                   | 1/2X |
| Imperial                      | \$10.50           | -                  | -       | <sup>a</sup> 0.115 | 0.17    | -        | 8             | <sup>b</sup> 10.785 | <sup>b</sup> 16.035 |      |
| Inyo, Mono and San Bernardino | 10.50             | -                  | -       | 0.30               | 0.17    | -        | 8             | 10.97               | 16.22               |      |
| Kern                          | 10.50             | -                  | -       | <sup>c</sup> 0.16  | 0.17    | -        | 8             | <sup>b</sup> 10.83  | <sup>b</sup> 16.08  |      |
|                               | 10.50             | -                  | -       | <sup>d</sup> 0.27  | 0.46    | -        | 8             | <sup>b</sup> 11.23  | <sup>b</sup> 16.48  |      |
| Los Angeles                   | 10.50             | 0.89               | -       | <sup>e</sup> 0.115 | 0.14    | -        | 8             | <sup>b</sup> 11.645 | <sup>b</sup> 16.895 |      |
| Orange                        | 10.50             | -                  | -       | <sup>f</sup> 0.11  | 0.11    | -        | 8             | <sup>b</sup> 10.72  | <sup>b</sup> 15.97  |      |
| Riverside                     | 10.50             | -                  | -       | <sup>g</sup> 0.20  | 0.16    | -        | 8             | <sup>b</sup> 10.86  | <sup>b</sup> 16.11  |      |
| San Diego                     | 10.50             | -                  | -       | 0.22               | 0.115   | -        | 8             | 10.835              | 16.085              |      |
|                               | 10.50             | -                  | -       | 0.24               | 0.12    | -        | 8             | 10.86               | 16.11               |      |
| San Luis Obispo               | 10.50             | -                  | -       | <sup>h</sup> 0.15  | 0.15    | -        | 8             | 10.80               | 16.05               |      |
|                               | 10.50             | -                  | -       | <sup>i</sup> 0.16  | 0.16    | -        | 8             | 10.82               | 16.07               |      |
| Santa Barbara                 | 10.50             | -                  | -       | <sup>j</sup> 0.12  | 0.12    | -        | 8             | <sup>b</sup> 10.74  | <sup>b</sup> 15.99  |      |
|                               | 10.50             | -                  | -       | <sup>k</sup> 0.13  | 0.13    | -        | 8             | <sup>b</sup> 10.76  | <sup>b</sup> 16.01  |      |
| Ventura                       | 10.50             | -                  | -       | 0.115              | 0.16    | -        | 8             | 10.775              | 16.025              |      |
|                               | 10.50             | 2.97               | -       | <sup>l</sup> 0.19  | 0.26    | -        | 8             | <sup>b</sup> 13.92  | <sup>b</sup> 19.17  |      |

## Craft is not apprenticeable.

**NOTE:** If there are two rates, the first rate is for routine work, the second rate is for complex work.

- <sup>a</sup> \$0.22 after 3 years of service.
- <sup>b</sup> Computation is based on the first years of employment. This rate should be increased by any applicable vacation increase as stated in other footnotes.
- <sup>c</sup> \$0.31 after 2 years of service.
- <sup>d</sup> \$0.54 after 2 years of service; \$0.81 after 3 years of service.
- <sup>e</sup> \$0.24 after 3 years of service; \$0.37 after 7 years of service.
- <sup>f</sup> \$0.22 after 4 years of service.
- <sup>g</sup> \$0.40 after 3 years of service.
- <sup>h</sup> \$0.23 after 2 years of service.
- <sup>i</sup> \$0.27 after 2 years of service.
- <sup>j</sup> \$0.38 after 3 years of service.
- <sup>k</sup> \$0.29 after 2 years of service.
- <sup>l</sup> \$0.31 after 2 years of service.

<sup>1</sup> This determination does not apply to work of a landscape laborer employed on landscape construction (work incidental to construction or post-construction maintenance during the plant installation and establishment period). The following is a description of the landscape work cover under this determination:

- ROUTINE* – mowing, watering, pruning, trimming, weeding, spraying, occasional planting and replacement of plants and janitorial work incidental to such landscape maintenance.
- COMPLEX* – servicing of irrigation and sprinkler systems, repairing of equipment use in such landscape maintenance.

**RECOGNIZED HOLIDAYS:** Holidays upon which the general prevailing hourly wage rate for Holiday work shall be paid, shall be all holidays in the collective bargaining agreement, applicable to the particular craft, classification, or type of worker employed on the project, which is on file with the Director of Industrial Relations. If the prevailing rate is not based on a collectively bargained rate, the holidays upon which the prevailing rate shall be paid shall be as provided in Section 6700 of the Government Code. You may obtain the holiday provisions for the current determinations on the Internet at <http://www.dir.ca.gov/OPRL/DPreWageDetermination.htm>. Holiday provisions for current or superseded determinations may be obtained by contacting the Office of the Director – Research Unit at (415) 703-4774.

**TRAVEL AND/OR SUBSISTENCE PAYMENT:** In accordance with Labor Code Sections 1773.1 and 1773.9, contractors shall make travel and/or subsistence payments to each worker to execute the work. You may obtain the travel and/or subsistence provisions for the current determinations on the Internet at <http://www.dir.ca.gov/OPRL/DPreWageDetermination.htm>. Travel and/or subsistence requirements for current or superseded determinations may be obtained by contacting the Office of the Director – Research Unit at (415) 703-4774.



GENERAL PREVAILING WAGE DETERMINATION MADE BY THE DIRECTOR OF INDUSTRIAL RELATIONS  
PURSUANT TO CALIFORNIA LABOR CODE PART 7, CHAPTER 1, ARTICLE 2, SECTIONS 1770, 1773 AND 1773.1  
FOR COMMERCIAL BUILDING, HIGHWAY, HEAVY CONSTRUCTION AND DREDGING PROJECTS

CRAFT: #LANDSCAPE/IRRIGATION LABORER/TENDER

DETERMINATION: SC-102-X-14-2017-2

ISSUE DATE: August 22, 2017

EXPIRATION DATE OF DETERMINATION: July 31, 2018\* Effective until superseded by a new determination issued by the Director of Industrial Relations.

Contact the Office of the Director – Research Unit at (415) 703-4774 for the new rates after ten days after the expiration date if no subsequent determination is issued.

LOCALITY: All localities within Imperial, Inyo, Kern, Los Angeles, Mono, Orange, Riverside, San Bernardino, San Luis Obispo, Santa Barbara and Ventura counties.

| CLASSIFICATION<br>(Journey person) | Employer Payments       |                          |         |                            |          |        | Straight-Time |                         | Overtime Hourly Rate         |                                 |                          |
|------------------------------------|-------------------------|--------------------------|---------|----------------------------|----------|--------|---------------|-------------------------|------------------------------|---------------------------------|--------------------------|
|                                    | Basic<br>Hourly<br>Rate | Health<br>and<br>Welfare | Pension | Vacation<br>and<br>Holiday | Training | Other  | Hours         | Total<br>Hourly<br>Rate | Daily <sup>b</sup><br>1 1/2X | Saturday <sup>b</sup><br>1 1/2X | Sunday/<br>Holiday<br>2X |
| Landscape/Irrigation Laborer       | \$31.38                 | \$7.12                   | \$7.53  | \$4.59 <sup>a</sup>        | \$0.69   | \$0.48 | 8             | \$51.79                 | \$67.48                      | \$67.48                         | \$83.17                  |
| Landscape Hydro Seeder             | \$32.48                 | \$7.12                   | \$7.53  | \$4.59 <sup>a</sup>        | \$0.69   | \$0.48 | 8             | \$52.89                 | \$69.13                      | \$69.13                         | \$85.37                  |

DETERMINATION: SC-102-X-14-2017-2A

ISSUE DATE: August 22, 2017

EXPIRATION DATE OF DETERMINATION: July 31, 2018\* Effective until superseded by a new determination issued by the Director of Industrial Relations.

Contact the Office of the Director – Research Unit at (415) 703-4774 for the new rates after ten days after the expiration date if no subsequent determination is issued.

LOCALITY: All localities within Imperial, Inyo, Kern, Los Angeles, Mono, Orange, Riverside, San Bernardino, San Luis Obispo, Santa Barbara and Ventura counties.

|  |         |        |        |                     |    |        |   |         |          |          |         |
|--|---------|--------|--------|---------------------|----|--------|---|---------|----------|----------|---------|
| Landscape/Irrigation Tender <sup>c</sup> | \$14.21 | \$2.25 | \$1.00 | \$1.27 <sup>a</sup> | -- | \$0.21 | 8 | \$18.94 | \$26.045 | \$26.045 | \$33.15 |
|--|---------|--------|--------|---------------------|----|--------|---|---------|----------|----------|---------|

#Indicates an apprenticeable craft, the applicable apprentice determination for this journeyman determination is Landscape Irrigation Fitter. The current apprentice wage rates are available on the Internet at <http://www.dir.ca.gov/OPRL/PWAppWage/PWAppWageStart.asp>. To obtain any apprentice wage rates as of July 1, 2008 and prior to September 27, 2012, please contact the Division of Apprenticeship Standards or refer to the Division of Apprenticeship Standards' Website at <http://www.dir.ca.gov/das/das.html>.

<sup>a</sup> Includes an amount per hour worked for Supplemental Dues.

<sup>b</sup> Rate applies to first 4 daily overtime hours and the first 12 hours on Saturday. All other time is paid at the Sunday and Holiday double-time rate.

<sup>c</sup> The first employee on the jobsite shall be a Landscape/Irrigation Laborer; the second employee on the jobsite must be an Apprentice or a Landscape/Irrigation Laborer; and the third and fourth employees may be Tenders. The fifth employee on the jobsite shall be a Landscape/Irrigation Laborer; the sixth employee must be an Apprentice or a Landscape/Irrigation Laborer; and the seventh and eight employees may be Tenders. Thereafter, Tenders may be employed with Landscape/Irrigation Laborers in a 50/50 ratio on each jobsite. However, plant establishment may be performed exclusively by Landscape/Irrigation Tenders without the supervision of a Journeyman.

RECOGNIZED HOLIDAYS: Holidays upon which the general prevailing hourly wage rate for Holiday work shall be paid, shall be all holidays in the collective bargaining agreement, applicable to the particular craft, classification, or type of worker employed on the project, which is on file with the Director of Industrial Relations. If the prevailing rate is not based on a collectively bargained rate, the holidays upon which the prevailing rate shall be paid shall be as provided in Section 6700 of the Government Code. You may obtain the holiday provisions for the current determinations on the Internet at <http://www.dir.ca.gov/OPRL/DPreWageDetermination.htm>. Holiday provisions for current or superseded determinations may be obtained by contacting the Office of the Director – Research Unit at (415) 703-4774.

TRAVEL AND/OR SUBSISTENCE PAYMENT: In accordance with Labor Code Sections 1773.1 and 1773.9, contractors shall make travel and/or subsistence payments to each worker to execute the work. You may obtain the Travel and/or subsistence provisions for the current determinations on the Internet at <http://www.dir.ca.gov/OPRL/DPreWageDetermination.htm>. Travel and/or Subsistence provisions for current or superseded determinations may be obtained by contacting the Office of the Director - Research Unit at (415) 703-4774.

**EXHIBIT D - TERM OF CONTRACT****RFP NO. 2018-014**

LANDSCAPE MAINTENANCE – ZONE 02  
 Maintenance of Parkway, Median, and Open space  
 Landscaping and Irrigation

**TERM OF CONTRACT**

- A. Following approval by all parties, the Contract will commence on July 1, 2018, and shall terminate June 30, 2023 (5) years thereafter.
- B. At the end of each fiscal year, the Contract may be amended to fund services for the following fiscal year with the concurrence of all parties. Written notice of the City's intent to invoke this subsection of the Contract shall be given to the Contractor at least thirty (30) days prior to the end of each fiscal year of the Contract.
- C. In considering the option to amend the Contract, as set forth in paragraph B above, the City shall determine the following:
- That the Contractor's performance during the preceding twelve months has been satisfactory, and
- That any request for increase of Contractor's compensation is based on an annual inflation adjustment based on the percentage increase calculated for the previous calendar year in the Riverside-San Bernardino-Ontario Regional Consumer Price Index for All Urban Consumers, as published by the Department of Labor's Bureau of Labor Statistics.
- D. At the expiration of its term, and with the concurrence of all parties, the Contract may be extended for up to three (3) additional periods of thirty (30) days each, subject to all terms and conditions in effect during the current term of the Contract. Written notice of the City's intent to invoke this subsection of the Contract shall be given to the Contractor at least fifteen (15) days prior to the expiration of the initial term of this Contract, or any extensions thereof.
- E. It should be noted that multi-year contracts may be continued each fiscal year only after funding appropriations and program approvals have been granted by the City Council of the City of Moreno Valley and the City Council acting in the capacity as President and Members of the Board of Directors of the Moreno Valley Community Services District. In the event that the City Council and/or the City Council acting in the capacity as President and Members of the Board of Directors for the Moreno Valley Community Services District does not grant necessary funding appropriations and/or program approval, the affected multiyear contract becomes null and void effective July 1st of the fiscal year for which such approvals have been denied.

EXHIBIT E – CONTRACTOR PROPOSAL



**CITY OF MORENO VALLEY**

---

**COMMUNITY SERVICES DISTRICT**

**RFP NO. 2018-014**

**LANDSCAPE MAINTENANCE –ZONE 02**

**Maintenance of Parkway, Median and Open Space  
Landscaping and Irrigation**



CA CONTRACTOR'S LIC # 592268 A, C-27, D-49  
6232 Santos Diaz St., IRWINDALE, CA 91702 • TEL 800•794•9458 • FAX 626•960•8477  
[www.mariposa-ca.com](http://www.mariposa-ca.com)

Attachment: Agreement for On-Site and/or Professional Services (3332 : APPROVE THE FIRST AMENDMENT TO THE ON-SITE AND/OR

# EXHIBIT E – CONTRACTOR PROPOSAL SUBMITTAL CHECKLIST

RFP NO. 2018-014

LANDSCAPE MAINTENANCE – ZONE 02  
Maintenance of Parkway, Median, and Open Space  
Landscaping and Irrigation

The following check list and associated documentation must be completed, signed and included for the RFP to be considered responsive:

**INCLUDE THIS COMPLETED AND SIGNED LIST WITH RFP SUBMITTAL PACKAGE.**

Mariposa Landscapes, Inc.  
Company Name (Please print)

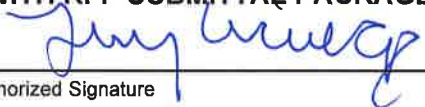
  
Authorized Signature

Joshua Cho  
Name of RFP Preparer

(626) 960-0196  
Preparer's Phone Number

joshua@mariposa-ca.com  
Preparer's Email Address

**SCHEDULE I – GENERAL INFORMATION – fillable form, print and return**

- Vendor Information
- References
- Proposed Facilities, Equipment and Personnel
- Communications and Traffic Safety
- Greenwaste Recycling
- List of Subcontractors

**SCHEDULE II – PROPOSAL SCHEDULES**

- Frequency of Services Table – print, sign and return
- Proposed Compensation Schedules – PlanetBids form submission
- Proposed Additional Work Price List - PlanetBids form submission
- Work Schedules (Monthly, Annual, and Material) – fillable form, print and return

**SCHEDULE III – FORMS – print, complete and return**

- Proposal Affirmation
- Non-Collusion Affidavit
- Certificate of Non-Discrimination
- Affirmation of Proposal Guarantee
- Bid Bond
- Faithful Performance Bond
- Labor and Materials Bond

Attachment: Agreement for On-Site and/or Professional Services (3332 : APPROVE THE FIRST AMENDMENT TO THE ON-SITE AND/OR

# M A R I P O S A L A N D S C A P E S I N C

B.5.b

## DIR

| Legal Name                | Registration Number | County      | City      | Registration Date | Expiration Date |
|---------------------------|---------------------|-------------|-----------|-------------------|-----------------|
| MARIPOSA LANDSCAPES, INC. | 1000005079          | LOS ANGELES | IRWINDALE | 05/17/2017        | 06/30/2018      |

## LICENSE



Attachment: Agreement for On-Site and/or Professional Services (3332 : APPROVE THE FIRST AMENDMENT TO THE ON-SITE AND/OR



CA CONTRACTOR'S LIC # 592268 A, C-27, D-49  
 6232 Santos Diaz St., IRWINDALE, CA 91702 • TEL 800•794•9458 • FAX 626•960•8477  
[www.mariposa-ca.com](http://www.mariposa-ca.com)

**EXHIBIT E – CONTRACTOR PROPOSAL  
SCHEDULE I – GENERAL INFORMATION**

**Attachment: Agreement for On-Site and/or Professional Services (3332 : APPROVE THE FIRST AMENDMENT TO THE ON-SITE AND/OR**

**VENDOR INFORMATION**

A. Company Name: Mariposa Landscapes Inc.

TYPE

- Sole proprietor
- Partnership
- Corporation

B. Company Physical Address  
(Street) 6232 Santos Diaz St.

(City, State, Zip) Irwindale, CA 91702

C. Company Mailing Address  
(Street) Same as above

(City, State, Zip) \_\_\_\_\_

D. Business Phone Number (626) 960-0196

E. Satellite Office Address (if applicable):  
N/A

F. Satellite Office Phone Number N/A

G. Contractor's Licensing Information: 592268,C27,A, C61/D49  
Landscaping, General Engineering

1. License number/Classification/Name Style: Contractor, Tree Service

2. Number of Years Operating Under the Above License Name Style: 40 yrs.

3. License Expiration Date: 04/30/2018

4. Current License Status: Active

5. Prior actions against this License?  Yes  No

6. If Yes, list the citation type and how it was resolved:  
N/A

H. Company's Federal Identification No.: 95-4245898

I. Name and Title(s) of Company Officers:  
Terry Noriega, President

Antonio Valenzuela, Secretary

\_\_\_\_\_

\_\_\_\_\_

\_\_\_\_\_

Attachment: Agreement for On-Site and/or Professional Services (3332 : APPROVE THE FIRST AMENDMENT TO THE ON-SITE AND/OR



- J. Department of Industrial Relations Registration No.: 1000005079
- K. Number of years the company has performed landscape maintenance services: 40 yrs
- L. Number of years the company has performed landscape maintenance services for public agencies: 35 yrs.
- M. Current Landscape Maintenance Operations

The City recognizes that the information provided in answer to this question is proprietary in nature and therefore the City will keep this information confidential to the extent permitted by law.

Total number of landscape maintenance contracts: 102  
 Percentage of total contracts with public agencies: 65%  
 Total dollar value of landscape maintenance contracts: \$17,500,000.00

N. Number of employees committed to landscape maintenance operations

|             |                    |                       |
|-------------|--------------------|-----------------------|
| Supervisors | Average wage scale | <u>\$ 71.00</u>       |
| Technicians | Average wage scale | <u>\$ 51.00 /Hr.*</u> |
| Foremen     | Average wage scale | <u>\$ 39.75 /Hr.*</u> |
| Laborers    | Average wage scale | <u>\$ 34.50 /Hr.*</u> |

\*Use the fully burdened rate (i.e., taxes, insurance, benefits, OH &P).  
 This is a prevailing wage project.

O. Type/number of vehicles and power equipment committed to landscape maintenance operations:

Motor vehicles

|   |                    |
|---|--------------------|
| Type <u>Dump Trucks &amp; Roll Offs</u> | Number <u>13,2</u> |
| Type <u>Full size Trucks</u>            | Number <u>123</u>  |
| Type <u>Med Duty Trucks</u>             | Number <u>2</u>    |
| Type <u>Small Pick up Trucks</u>        | Number <u>40</u>   |
| Type <u>Sweeper</u>                     | Number <u>1</u>    |

Power Equipment

|  |                     |
|--|---------------------|
| Type <u>Mowers: Ride-on; Walk behind</u> | Number <u>91;56</u> |
| Type <u>Backpack Blowers</u>             | Number <u>118</u>   |
| Type <u>Hedgetrimmers</u>                | Number <u>126</u>   |
| Type <u>String Trimmers</u>              | Number <u>118</u>   |
| Type <u>Edgers</u>                       | Number <u>72</u>    |
| Reel Mowers                              | 5                   |
| Roll Off Bins                            | 24                  |
| Trailers                                 | 21                  |

Attachment: Agreement for On-Site and/or Professional Services (3332 : APPROVE THE FIRST AMENDMENT TO THE ON-SITE AND/OR

## REFERENCES

List a minimum of three (3) references for public agency landscape maintenance contracts that are either current and/or have been successfully completed within the last two (2) years.

The following questions will be asked of each reference agency:

1. List the number of agreements and years under agreement.
2. Explain the scope of the agreement(s), acreage amounts, and location(s).
3. Identify the agreement amount(s).
4. Describe the quantity and quality of staffing.
5. Describe the training/technical skills (i.e., irrigation/pest control/ equipment operation/safety).
6. Explain the communication abilities and language preferences of staff.
7. Describe staff appearance, uniforms, and use of safety equipment.
8. Explain the availability of additional personnel for extra work/special projects.
9. Explain the working order of equipment used.
10. Describe the effectiveness of communications system.
11. Explain the contractor's knowledge of project and contract standards.
12. Describe the contractor's ability to respond to complaints/requests in a timely fashion.
13. Identify if the contractor is willing to resolve questions, disputes, and deficiencies short of "formal" sanctions (i.e., monetary penalties, contract deductions, liquidated damages, claims against bonds).
14. Explain the accuracy and timeliness of billing and invoicing.
15. Identify if contract(s) had been successfully completed to term.
16. Would you accept future proposals/bids from this Proposer?

| Reference #1  |   |
|---|---|
| Public Agency Name                                    | City of Palm Desert                             |
| Agency Address  | 73-510 Fred Waring Drive, Palm Desert, CA 92260 |
| Agency Contact Responsible for administering contract | Randy Chavez                                    |
| Contact telephone                                     | (760) 902-9064                                  |
| Agreement Name(s)                                     | Palm Desert Areas 6 & 9                         |
| Annual Agreement Amount(s)                            | \$295,374.00                                    |
| Number of acres maintained per contract               | 5 Acres   |
| Location(s) of areas maintained.                      | Areas 6 and 9                                   |
| Length of Contract(s)/expiration date                 | 2010 - Current                                  |

| Reference #2  |   |
|---|---|
| Public Agency Name                                    | City of Rancho Cucamonga                |
| Agency Address  | 9153 9th St. Rancho Cucamonga, CA 91730 |
| Agency Contact Responsible for administering contract | Steve Relph                             |
| Contact telephone                                     | (909) 477-2730 x 4116                   |
| Agreement Name(s)                                     | City of Rancho Cucamonga                |
| Annual Agreement Amount(s)                            | \$1,345,769.28                          |
| Number of acres maintained per contract               | 124 Acres                               |
| Location(s) of areas maintained.                      | Various Locations                       |
| Length of Contract(s)/expiration date                 | 1989- Current                           |

| Reference #3  |                                      |
|---|--------------------------------------|
| Public Agency Name                                    | City of Tustin                       |
| Agency Address  | 300 Centennial Way, Tustin, Ca 92780 |
| Agency Contact Responsible for administering contract | Jim Sulli                            |
| Contact telephone                                     | (714) 573-3360                       |
| Agreement Name(s)                                     | Tustin                               |
| Annual Agreement Amount(s)                            | \$546,204.00                         |
| Number of acres maintained per contract               | 63 ACres                             |
| Location(s) of areas maintained.                      | All Medians in the City              |
| Length of Contract(s)/expiration date                 | 1989 - Current                       |

| Reference #4  |   |
|---|---|
| Public Agency Name                                    | City of Santa Ana                           |
| Agency Address  | 20 Civic Center Plaza , Santa Ana, CA 92701 |
| Agency Contact Responsible for administering contract | Mike Lopez                                  |
| Contact telephone                                     | (714) 647-3324                              |
| Agreement Name(s)                                     | City of Santa Ana                           |
| Annual Agreement Amount(s)                            | \$882,209.00                                |
| Number of acres maintained per contract               | Approx 12 Acres medians only                |
| Location(s) of areas maintained.                      | Parks and medians                           |
| Length of Contract(s)/expiration date                 | 2014- Current                               |

| Reference #5  |   |
|---|---|
| Public Agency Name                                    | City of Arcadia                         |
| Agency Address  | 11800 Goldring Ave. Arcadai, CA 91006   |
| Agency Contact Responsible for administering contract | Dave Thompson                           |
| Contact telephone                                     | (626) 256-6676                          |
| Agreement Name(s)                                     | Arcadia                                 |
| Annual Agreement Amount(s)                            | \$470,000.00                            |
| Number of acres maintained per contract               | Approx. 50-60 Acres                     |
| Location(s) of areas maintained.                      | Parks, medians, Facilities and Downtown |
| Length of Contract(s)/expiration date                 | 2013 - Current                          |

**PROPOSED FACILITIES, EQUIPMENT AND PERSONNEL**

Attach additional sheets as necessary to provide a full and comprehensive response.

**A. Facilities**

List the facility(ies), location(s), and/or address(es) where work crews and equipment will be dispatched.

|  |
|--|
| <p>Fontana Office/Yard<br/>11093 Almond Ave, Fontana, CA 92337</p> <p>We are currently in the process of securing a location in close proximity to the City of Moreno Valley and upon award of contract will dispatch the crews from that location</p> |
|--|

**B. Equipment**

List the equipment, motor vehicles, and tools, in the areas below that will be furnished to execute work tasks specified in the Agreement and Scope of Work. Indicate with an "S" any listed equipment to be shared with another contract/project. List both powered and hand equipment/tools

|  |
|--|
| <p>General Equipment:</p> <p>String Trimmers<br/>Hedge Trimmers<br/>Backpack Blowers<br/>Trailers<br/>Various hand tools</p> |
|--|

Attachment: Agreement for On-Site and/or Professional Services (3332 : APPROVE THE FIRST AMENDMENT TO THE ON-SITE AND/OR

| Motor Vehicles:  |
|--|
| Full size pick up trucks<br>Irrigation Truck<br>Applicator truck |

| Turf Maintenance Power Equipment/Tools:      |
|--|
| Mowers (s) if needed<br>Edgers (s) if needed |

| Tree, Shrub, Ground Cover Trimming/Pruning Equipment/Tools:  |
|--|
| Chain Saw(s)<br>Hedge trimmers<br>Long Hedge Trimmers (s)<br>Pole Saw (s)<br>Hand pruners, Lopers, Rakes |

Attachment: Agreement for On-Site and/or Professional Services (3332 : APPROVE THE FIRST AMENDMENT TO THE ON-SITE AND/OR

|  |
|--|
| Irrigation System Maintenance Equipment:   |
| Shovels (various)<br>Pipe Cutter<br>Pipe Wrenches (various), Screw drivers (various), piles<br>Volt meter<br>Wire Tracer, Hand held remote (s) if needed |

|  |
|--|
| Fertilizer Application Equipment:                              |
| Walk behind broadcast spreader<br>Hand held broadcast spreader |

|                                   |
|-----------------------------------|
| Pesticide Application Equipment:  |
| Spray tank(s)<br>Backpack sprayer |

Attachment: Agreement for On-Site and/or Professional Services (3332 : APPROVE THE FIRST AMENDMENT TO THE ON-SITE AND/OR

C. Personnel

List the employees, both labor and supervision, to be routinely assigned to execute work tasks specified in the agreement, and Scope of Work. Be sure to note by title any applicable licenses/certifications held by assigned personnel. Indicate with an "S" if listed personnel are to be shared with another contract/project.

General Landscape Maintenance  
*List labor, administrative, and field supervisory personnel – include any relevant education, certification and/or licensing information for each person listed.*

Luis Valenzuela, Maintenance Division Manager  
CLT,QAC,Arborist  
Antonio Karraa, Maintenance Area Manager  
Jesus Ramirez, Maintenance Account Manager  
Foreman To be assigned upon award of contract.  
  
\*See attached Resumes and certifications

Tree Trimming/Maintenance  
*List any ISA or equivalent certified personnel.*

Tasks to be performed by assigned crew  
  
\*See attached resumes and certifications

Attachment: Agreement for On-Site and/or Professional Services (3332 : APPROVE THE FIRST AMENDMENT TO THE ON-SITE AND/OR



# M A R I P O S A

## L A N D S C A P E S I N C

### STAFF RESUMES

#### Maintenance

##### Luis Valenzuela – Landscape Maintenance Division Manager, Southern California

- 22 years of experience in landscape and construction operations
- Qualified Applicator Certificate: Category B
- Certified Landscape Technician: Irrigation
- Certified Arborist: International Society of Arboriculture: # WE-8713A
- Certification – Effective Business Leadership & Development – PDC/GCC

##### Antonio Karraa -Landscape Maintenance Area Manager

- 26 Years in the landscape maintenance industry.
- Extensive knowledge of irrigation, chemical application and all aspects of maintenance services with Public Works contracts.
- Previous experience includes, organizing and administering a wide range of maintenance and support for the Parks and Landscape Division for large municipalities.
- Accountabilities include maintenance of trees, parks, street medians, plazas, slopes and open space areas within Assessment Districts.

##### Jesus Ramirez – Landscape Maintenance Account Manager

- 21 years of experience in landscape maintenance
- Qualified Applicator License: Category B, C
- Certified Landscape Technician: Ornamental Maintenance , Turf Maintenance
- Certificate – Irrigation Design
- Certificate – Irrigation Troubleshooting
- CVAG Overseeding Certificate



## Tree Care

### Dennis Jones – Tree Care Regional Division Manager – Southern California

- 15 years of experience in arbor care
- B.S. Degree in Urban Forestry, Cal Poly San Luis Obispo
- International Society of Arboriculture (ISA): Certified Arborist: # WE-5700A
- TCIA Certified Tree Safety Professional (CTSP): #843
- Qualified Applicators License (QAL): #108771 Categories B, C, F
- ISA Qualified Tree Risk Assessment
- Wildlife Protector Certification
- Notary Public

### Gulliver Erickson – Tree Care Account Manager

- 27 years of experience in arbor care
- International Society of Arboriculture (ISA): Certified Arborist: WE 10288A
- Tree Care Industry Association (TCIA) Certified Tree Care Safety Professional (CTSP): # 01528
- Thousands of hours completed in Arboriculture Training in Australia

### Orlando Baeza – Tree Division Contract Manager (Inland Empire)

- 10 years of experience in the industry
- Certified Tree care Safety Professional
- Certified Ground Operations Specialist



|  |
|--|
| <p>Irrigation System Maintenance<br/> <i>List technical personnel – include any relevant education, certification and/or licensing information for each person listed.</i></p> |
| <p>Irrigator to be assigned upon award of contract</p> <p>* See attached resumes and certifications</p>  |

|   |
|---|
| <p>Pesticide Application<br/> <i>List licensed and/or certified personnel. All non-licensed, non-certified personnel must have received verifiable annual training.</i></p> |
| <p>Tasks to be performed by assigned crew</p> <p>*See attached resumes and certifications</p>   |

**COMMUNICATIONS AND TRAFFIC SAFETY**

Attach additional sheets as necessary to provide a full and comprehensive response.

**A. Communications**

Exhibit A requires the contractor possess and maintain an effective Contractor-wide communications system. The Proposer must also designate responsible staff to be available on a twenty-four (24) hour basis to receive, and respond to emergency calls.

Attachment: Agreement for On-Site and/or Professional Services (3332 : APPROVE THE FIRST AMENDMENT TO THE ON-SITE AND/OR



## A. Communications

### Communication

All communications will be routed through our main office and dispatch center in Irwindale. A 24-hour “800” number will be provided to the City of Moreno Valley and will use all of the current communication methods such as two-way radios and cellular phones. Our response time will meet or exceed the City’s expectations.



The foreperson and/or the on-site principal landscaper assigned to the project will have the direct communication with the City’s representative. The City of Moreno Valley can expect a person in this position that can communicate English, both verbally & in writing and be knowledgeable in landscape maintenance operations. These methods combined with instant communications via 24-hour telephone monitoring and cellular phone, email or fax enables the City of Moreno Valley to receive a quick response to any maintenance concerns.

### Technical Competence

Our Company utilizes the newest technology which allows us for quick responses with all the necessary details to better serve our clients.

Our software and Programs include: Timberline, Alpha, Blue Beam Revu, Google Earth Pro, Daft Logic. Microsoft Office: Word, Excel, PDF Converter Pro,

Our project managers and supervisors are equipped with laptops, iPads and Smart phones. While out of the office on business trips, our managers and supervisors are able to communicate efficiently via email with our clients as if they were in the office

### Conclusion

It is our goal to provide the City of Moreno Valley with professional landscape maintenance services with the emphasis on results. Results are what we as a contractor and ultimately the City of Moreno Valley management will be judged by. It is our goal to provide the professional results as indicated in the intent of the specifications. We intend to provide clean and well-maintained areas that the City of Moreno Valley and we can be proud of.



Describe your internal communications system, both in the office and in the field, and how it will enable you to provide the communication capability as required in Scope of Services specifications. Also, describe how your Proposer will provide the required twenty-four (24) hour communication capability.

See attached document

**B. Traffic Safety**

Exhibit A requires the contractor to provide safe and effective work area traffic control, per Caltrans' "Manual On Uniform Traffic Control Devices 2012 (or most current revised version) California Supplement, Part 6, Temporary Traffic Control".

Describe your general traffic control practices and training, and how your Proposer intends, if selected, to conduct work area traffic control operations to provide service for this project.

See attached document



## B. Traffic Safety

Mariposa Landscapes Inc. follows strict guidelines set by Caltrans, local ordinances, contract specifications, and the Watch book guide or equivalent.

Many of our crews in the divisions of landscape maintenance, landscape construction, and tree care, have extensive experience in traffic control whenever it is required to work along the road or inside medians, flagmen included as necessary.



In addition to the abovementioned list of sources for traffic control, tree division personnel use training materials furnished by the Tree Care Industry Association.

An example of a guide developed for in-house use is included. However, in the event that there is a conflict between safety material prepared for specific tasks and municipal or state guidelines, traffic control ordinances will prevail.

Attachment: Agreement for On-Site and/or Professional Services (3332 : APPROVE THE FIRST AMENDMENT TO THE ON-SITE AND/OR





RFP NO. 2018-014  
LANDSCAPE MAINTENANCE – ZONE 02  
EXHIBIT E – SCHEDULE I

MARIPOSA LANDSCAPES INC.



Meeting Date: \_\_\_\_\_

Due: \_\_\_\_\_

Crew or Job Name: \_\_\_\_\_

Supervisor and Trainer: \_\_\_\_\_



**General Guidelines**

- 1 Always check with your supervisor if a lane closure is mandatory. *Follow local ordinances.*
- 2 If you are moving through a median a safety vest is the minimum requirement.
- 3 Be prepared to *change* any of these guidelines when necessary to *improve safety conditions.*
- 4 **Never turn your back to traffic any longer than necessary. Stay on the alert. If you are working on the edge of a median, DO NOT TURN YOUR BACK TO TRAFFIC.**
- 5 Use any **other signage** necessary to alert and warn oncoming traffic.
- 6 If possible, do your work on medians during the low-traffic hours.

If a lane closure is not mandatory, and you will be in the median for longer than 10 minutes, a) cone the median with at least 4 cones as shown in the following examples, b) the number of cones used depends on the length of the median, c) place cones against the curb at the ends of the median, and at the halfway point along its length on both sides.

Example #1

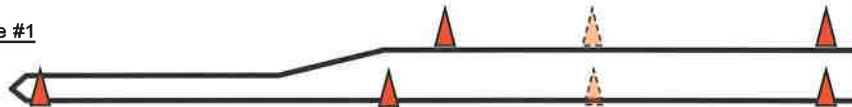

Example #2

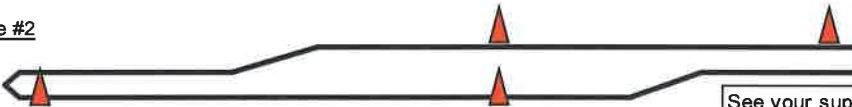

Example #3

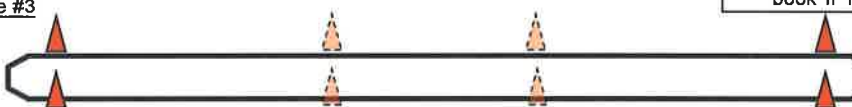

See your supervisor for a copy of the WATCH book if needed.

Use your **best judgement** for cone placement. Sometimes it may be necessary to place the cones on top of the curb instead of against it as shown below.

Example #4a

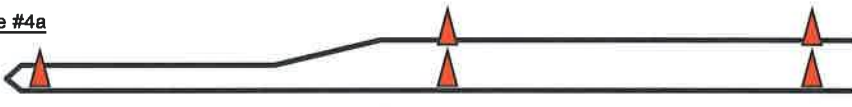

Example #4b

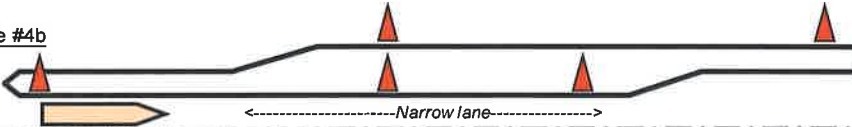

Always cone the truck and trailer when parked.

Mandatory Cone

Optional Cone



## GREENWASTE RECYCLING

AB 939 mandates that the City of Moreno Valley divert from landfills fifty percent (50%) of the solid waste, including greenwaste, generated within its jurisdiction.

Describe your program to ensure that the City receives credit for greenwaste that will be generated from executing the project's Scope of Work. Include the name(s), address(es) and phone number(s) of the recycling facility(ies) that will be accepting the greenwaste generated from your operations on the project. If planning to use any recycled greenwaste products (mulch, compost, soil amendments, etc.) on the project, please give name/address/phone information of the producer if different from those listed above.

See attached document





## Green waste recycling

Mariposa Landscapes, Inc. uses effort to initiate “green” environment and energy conservation.

Our company has a recycling program for green waste and paper products. We implement this program at our local offices and at all the job sites.

Mariposa currently uses hybrid vehicles and is researching and looking forward to obtaining hybrid equipment to be used on our contracts. We are striving to be as environmentally conscience as possible and are expanding our operations to achieve this goal.

Mariposa works with all its clients to assure optimum water usage where possible. Mariposa notifies all project managers of the green initiatives prior to the award of.



### FACILITY:

Agua Mansa MRF, LLC  
1830 Agua Mansa Rd.  
Riverside, CA 92509  
(951) 786-0544





## Environmental Mission Statement

Being committed to protecting the environment has been an embraced and significant value since the inception of the company. As a result, all personnel diligently follow and comply with applicable environmental laws and regulations implemented by state, local and federal government agencies, and as requested by private accounts.



We recognize our responsibility to the surrounding communities and to the accounts we serve, as a result of our function in developing or maintaining thousands of acres of greenbelts, parks, commercial landscapes, roadsides or medians and schools.

We work aggressively with our clients and field personnel to develop methods to improve water conservation, properly dispose of green waste, employ safe fertilization methods, protect natural habitats, recycle used paper, use pesticide-free methods of weed removal, maintain arborist-certified tree pruning operations and train our personnel in industry standard techniques for optimal on-the-job performance.

In summary, through conservation of resources, employing professional techniques in our operations, and preventive and precautionary methods to preserve and maintain safe and healthy landscapes, we at Mariposa are committed to environmentally improving our communities.



**LIST OF SUBCONTRACTORS**

In compliance with the provisions of Government Code, Section 4102, the undersigned Contractor sets forth the name and location (address) of the place of business of each subcontractor who will perform work, labor or render service to the Contractor in or about the construction of the work or improvement in an amount in excess of one-half of one percent (0.5%) of the general contractor's total Proposal, and the portion of the work which will be done by each subcontractor, as follows.

In compliance with Labor Code 1771.1(a), please include any subcontractor's DIR registration number.

| Name, current DIR No., License and Classification No. | Business Address and Telephone | Description of Work |
|---|--------------------------------|---------------------|
| N/A   |                                |                     |
|   |                                |                     |
|   |                                |                     |
|   |                                |                     |
|   |                                |                     |
|   |                                |                     |
|   |                                |                     |

Attachment: Agreement for On-Site and/or Professional Services (3332 : APPROVE THE FIRST AMENDMENT TO THE ON-SITE AND/OR

EXHIBIT E – CONTRACTOR PROPOSAL

**SCHEDULE II – PROPOSAL SCHEDULES**

Attachment: Agreement for On-Site and/or Professional Services (3332 : APPROVE THE FIRST AMENDMENT TO THE ON-SITE AND/OR

Landscape Maintenance Districts - ZONE 02  
RFP 2018-014

Frequency of Services Table – Base Work

| Scope of Work - Agreement Specification | Title  | Summary of Work                   | Frequency                            |                                      |                                      |
|---|--|-----------------------------------|--------------------------------------|--------------------------------------|--------------------------------------|
|   |  |                                   | Level 1 Service                      | Level 2 Service                      | Level 3 Service                      |
|   |  |                                   | (4 week)                             | (8 week)                             | (12 week)                            |
| Exhibit A, Section 2                    | Turf Care                                      | Mow/edge/trim                     | Weekly                               | Every other week                     | Every other week                     |
|   |  | Aeration                          | Bi-annually (Spring & Fall)          | Bi-annually (Spring & Fall)          | Annually (Spring)                    |
| Exhibit A, Section 4                    | Shrub Care                                     | Prune/trim                        | Monthly                              | 6 times per year                     | 4 times per year                     |
| Exhibit A, Section 5                    | Ground Cover                                   | Prune/trim                        | Monthly                              | 6 times per year                     | 4 times per year                     |
| Exhibit A, Section 9                    | Weed Control                                   | Weed Control                      | Monthly                              | 6 times per year                     | 4 times per year                     |
| Exhibit A, Section 10                   | Irrigation                                     | Irrigation Maint./Repair          | Weekly                               | Weekly                               | Weekly                               |
| Exhibit A, Section 11                   | Debris/Litter                                  | Trash/Debris Removal              | Weekly                               | Weekly                               | Every other week                     |
| Exhibit A, Section 8                    | Water Quality Basins                           | WQB Bottom Vegetation             |                                      | Annually                             |                                      |
|   |  | Forebays and Outlet Structures    |                                      | Bi-annually                          |                                      |
|   |  | Sand Bed Maintenance              |                                      | 2 times per year (Spring and Fall)   |                                      |
|   |  | Irrigation                        | Weekly                               | Weekly                               | Every other week                     |
|   |  | Trash/Debris Removal              | Weekly                               | Weekly                               | Every other week                     |
| Exhibit A, Section 6                    | Channel Thinning                               | Vegetative thinning               |                                      | Annually                             |                                      |
|   |  | Weeding                           |                                      | Quarterly                            |                                      |
|   |  | Irrigation                        |                                      | Weekly                               |                                      |
|   |  | Trash/Debris Removal              |                                      | Monthly                              |                                      |
| Exhibit A, Section 12                   | Turf Fertilization <sup>1</sup>                | Turf Fertilization                | 3 times per year (Feb., Jun. & Oct.) | 3 times per year (Feb., Jun. & Oct.) | 3 times per year (Feb., Jun. & Oct.) |
| Exhibit A, Section 12                   | Shrub/ Ground Cover Fertilization <sup>1</sup> | Shrub/ Ground Cover Fertilization | 2 times per year (Apr. & Sep.)       | 1 time per year (Apr.)               | 1 time per year (Apr.)               |
| Exhibit A, Section 9 and 20             | Pre-emergent <sup>1</sup>                      | Pre-emergent                      | 2 times per year (Spring & Fall)     | 2 times per year (Spring & Fall)     | 2 times per year (Spring & Fall)     |

| Scope of Work - Agreement Specification | Title                                   | Summary of Work                            | Frequency                    |                   |                 |                 |
|---|---|--|------------------------------|-------------------|-----------------|-----------------|
|   |   |  | Level 1 Service              | Level 2 Service   | Level 3 Service | Level 4 Service |
|   |   |  | Monthly                      | Every other Month | Quarterly       | Annually        |
| Exhibit A, Section 7                    | Paseo Maintenance (6 maintenance areas) | Annual Weed Abatement                      | 1 time per year              | 1 time per year   | 1 time per year | 1 time per year |
|   |   | 24" clearance/structures                   | 1 maintenance area per month | Every other Month | Quarterly       | Annually        |
|   |   | Irrigation                                 | Weekly                       | Monthly           | Monthly         | Monthly         |
|   |   | Shrub trimming/clearing from trails/fences | 1 maintenance area per month | Every other Month | Quarterly       | Annually        |
|   |   | Trash/Debris Removal                       | 1 maintenance area per month | Every other Month | Quarterly       | Annually        |

| Scope of Work - Agreement Specification | Title           | Summary of Work             | Frequency       |                   |                 |                 |
|---|-----------------|-----------------------------|-----------------|-------------------|-----------------|-----------------|
|   |                 |                             | Level 1 Service | Level 2 Service   | Level 3 Service | Level 4 Service |
|   |                 |                             | Monthly         | Every other Month | Quarterly       | Annually        |
| Exhibit A, Section 33                   | Reporting Forms | Irrigation Report           |                 | Weekly            |                 |                 |
| Exhibit A, Section 33                   | Reporting Forms | Greenwaste Recycling Report |                 | Monthly           |                 |                 |
| Exhibit A, Section 33                   | Reporting Forms | Landscape Services Report   |                 | Monthly           |                 |                 |

Footnotes

<sup>1</sup> Specification of month to be approved by Director in advance of application.

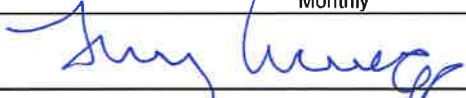
  
SIGNATURE

By signing, I hereby acknowledge review of the aforementioned Frequency of Services and have incorporated reference of the frequencies in the Proposal Schedule, including the proposed monthly and annual schedule sheets for the services to be provided consistent with the terms of this Agreement.

Attachment: Agreement for On-Site and/or Professional Services (3332 : APPROVE THE FIRST

## Bid Results for Project Landscape Maintenance Services for Zone 02 (2018-014)

Issued on 02/05/2018

Bid Due on March 5, 2018 10:00 AM (Pacific)

Exported on 04/11/2018

| Line Totals (Unit Price * Quantity) |   |  |   |                 |          |                             |
|-------------------------------------|---|--|---|-----------------|----------|-----------------------------|
| Item Num                            | Section   | Description  | Reference   | Unit of Measure | Quantity | Mariposa Landscapes, Inc. - |
| 1                                   | Compensation Schedule, Zone 02 Parkways, Planters, Current Service Level 1 (Monthly Cost)                                 | Zone 02 Parkways - 265,280 Square Feet of Planters                                   | Current Service Level, Level 1 (every 4 weeks) Monthly Cost   | Cost per Month  | 1        | \$5,508.0000                |
| 2                                   | Compensation Schedule, Zone 02 Parkways, Planters, Current Service Level 1 (Annual Cost)                                  | Zone 02 Parkways - 265,280 Square Feet of Planters                                   | Current Service Level, Level 1 (every 4 weeks) Annual Cost    | Cost per Month  | 12       | \$66,096.0000               |
| 3                                   | Compensation Schedule, Zone 02 Parkways, Planters, Optional Service Level 2 (Monthly Cost)                                | Zone 02 Parkways - 265,280 Square Feet of Planters                                   | Optional Service Level, Level 2 (every 8 weeks) Monthly Cost  | Cost per Month  | 1        | \$4,839.0000                |
| 4                                   | Compensation Schedule, Zone 02 Parkways, Planters, Optional Service Level 2 (Annual Cost)                                 | Zone 02 Parkways - 265,280 Square Feet of Planters                                   | Optional Service Level, Level 2 (every 8 weeks) Annual Cost   | Cost per Month  | 12       | \$58,068.0000               |
| 5                                   | Compensation Schedule, Zone 02 Parkways, Planters, Optional Service Level 3 (Monthly Cost)                                | Zone 02 Parkways - 265,280 Square Feet of Planters                                   | Optional Service Level, Level 3 (every 12 weeks) Monthly Cost | Cost per Month  | 1        | \$3,982.0000                |
| 6                                   | Compensation Schedule, Zone 02 Parkways, Planters, Optional Service Level 3 (Annual Cost)                                 | Zone 02 Parkways - 265,280 Square Feet of Planters                                   | Optional Service Level, Level 3 (every 12 weeks) Annual Cost  | Cost per Month  | 12       | \$47,784.0000               |
| 7                                   | Compensation Schedule, Zone 02 Paseos, Open Space, Current Service Level 1 (Monthly Cost)                                 | Zone 02 Paseos - 3,308,892 square feet of Open Space                                 | Current Service Level 1 (Monthly) Monthly Cost                | Cost per Month  | 1        | \$3,920.0000                |
| 8                                   | Compensation Schedule, Zone 02 Paseos, Open Space, Current Service Level 1 (Annual Cost)                                  | Zone 02 Paseos - 3,308,892 square feet of Open Space                                 | Current Service Level 1 (Monthly) Annual Cost                 | Cost per Month  | 12       | \$47,040.0000               |
| 9                                   | Compensation Schedule, Zone 02 Paseos, Open Space, Optional Service Level 2 (Monthly Cost)                                | Zone 02 Paseos - 3,308,892 square feet of Open Space                                 | Service Level 2 (Every Other Month) Monthly Cost              | Cost per Month  | 1        | \$2,800.0000                |
| 10                                  | Compensation Schedule, Zone 02 Paseos, Open Space, Optional Service Level 2 (Annual Cost)                                 | Zone 02 Paseos - 3,308,892 square feet of Open Space                                 | Service Level 2 (Every Other Month) Annual Cost               | Cost per Month  | 12       | \$33,600.0000               |
| 11                                  | Compensation Schedule, Zone 02 Paseos, Open Space, Optional Service Level 3 (Monthly Cost)                                | Zone 02 Paseos - 3,308,892 square feet of Open Space                                 | Service Level 3 (Quarterly) Monthly Cost                      | Cost per Month  | 1        | \$2,571.0000                |
| 12                                  | Compensation Schedule, Zone 02 Paseos, Open Space, Optional Service Level 3 (Annual Cost)                                 | Zone 02 Paseos - 3,308,892 square feet of Open Space                                 | Service Level 3 (Quarterly) Annual Cost                       | Cost per Month  | 12       | \$30,852.0000               |
| 13                                  | Compensation Schedule, Zone 02 Paseos, Open Space, Optional Service Level 4 (Monthly Cost)                                | Zone 02 Paseos - 3,308,892 square feet of Open Space                                 | Service Level 4 (Annually) Monthly Cost                       | Cost per Month  | 1        | \$2,372.0000                |
| 14                                  | Compensation Schedule, Zone 02 Paseos, Open Space, Optional Service Level 4 (Annual Cost)                                 | Zone 02 Paseos - 3,308,892 square feet of Open Space                                 | Service Level 4 (Annually) Full Annual Cost                   | Cost per Month  | 12       | \$28,464.0000               |
| 15                                  | Compensation Schedule, Alternative Bid Item, Supplemental Weed Control (Naturally Derived Materials or Methods), Parkways | Naturally Derived Materials or Methods of Weed Control on 265,280 sq. ft. of Planter | Cost for 1 Month at Service Level 1, every 4 weeks            | Cost per Month  | 1        | \$1,339.0000                |
| 16                                  | Compensation Schedule, Alternative Bid Item, Supplemental Weed Control (Naturally Derived Materials or Methods), Parkways | Naturally Derived Materials or Methods of Weed Control on 265,280 sq. ft. of Planter | Cost for 12 Months at Service Level 1, every 4 weeks          | Cost per Month  | 12       | \$16,068.0000               |

Attachment: Agreement for On-Site and/or Professional Services (3332 : APPROVE THE FIRST

Bid Results for Project Landscape Maintenance Services for Zone 02 (2018-014)  
 Issued on 02/05/2018  
 Bid Due on March 5, 2018 10:00 AM (Pacific)  
 Exported on 04/11/2018

| Line Totals (Unit Price * Quantity) |   |   |  |                 |          |                             |
|-------------------------------------|---|---|--|-----------------|----------|-----------------------------|
| Item Num                            | Section   | Description   | Reference  | Unit of Measure | Quantity | Mariposa Landscapes, Inc. - |
| 17                                  | Compensation Schedule, Alternative Bid Item, Supplemental Weed Control (Naturally Derived Materials or Methods), Paseos | Naturally Derived Materials or Methods of Weed Control on 3,308,892 sq. ft. of Open Space                                 | Cost for 1 Month at Service Level 2, every 8 weeks   | Cost per Month  | 1        | \$3,798.0000                |
| 18                                  | Compensation Schedule, Alternative Bid Item, Supplemental Weed Control (Naturally Derived Materials or Methods), Paseos | Naturally Derived Materials or Methods of Weed Control on 3,308,892 sq. ft. of Open Space                                 | Cost for 12 Months at Service Level 2, every 8 weeks | Cost per Month  | 12       | \$45,576.0000               |
| 19                                  | Additional Work Price List, One (1) gallon shrub/vine/ground cover in place   | One (1) gallon shrub/vine/ground cover  |  | each            | 1        | \$10.0000                   |
| 20                                  | Additional Work Price List, Five (5) gallon shrub/vine/ground cover in place  | Five (5) gallon shrub/vine/ground cover   |  | each            | 1        | \$28.0000                   |
| 21                                  | Additional Work Price List, Five (5) gallon tree in place (stakes included)   | Five (5) gallon tree including stakes   |  | each            | 1        | \$35.0000                   |
| 22                                  | Additional Work Price List, Fifteen (15) gallon tree in place (stakes included)   | Fifteen (15) gallon tree including stakes   |  | each            | 1        | \$145.0000                  |
| 23                                  | Additional Work Price List, 24" box tree in place (stakes included)   | 24" box tree including stakes   |  | each            | 1        | \$398.0000                  |
| 24                                  | Additional Work Price List, 36" box tree in place (guy wires included)  | 36" box tree including wires  |  | each            | 1        | \$925.0000                  |
| 25                                  | Additional Work Price List, Additional labor  | Additional labor  |  | man hour        | 1        | \$34.5000                   |
| 26                                  | Additional Work Price List, Additional Irrigation Technician  | Additional Irrigation Technician  |  | man hour        | 1        | \$51.0000                   |
| 27                                  | Additional Work Price List, Irrigation Repair Parts at Cost Plus a Specified Percent                                    | Please provide the Markup Percentage for Irrigation Repair Parts in the comment section. Enter \$0.00 as your unit price. |  | percent         | 0        | 15%                         |
| 28                                  | Cost for Additional Work Added To Base Work as Needed, Planter, 4-Week Service Level                                    | Trees, Shrubs, Ground Cover   | Service Level 1, 4-Week                              | Square Foot     | 1        | \$0.0310                    |
| 29                                  | Cost for Additional Work Added To Base Work as Needed, Planter, 8-Week Service Level                                    | Trees, Shrubs, Ground Cover   | Service Level 2, 8-Week                              | Square Foot     | 1        | \$0.0300                    |
| 30                                  | Cost for Additional Work Added To Base Work as Needed, Planter, 12-Week Service Level                                   | Trees, Shrubs, Ground Cover   | Service Level 3, 12-Week                             | Square Foot     | 1        | \$0.0290                    |

Attachment: Agreement for On-Site and/or Professional Services (3332 : APPROVE THE FIRST

Bid Results for Project Landscape Maintenance Services for Zone 02 (2018-014)  
Issued on 02/05/2018  
Bid Due on March 5, 2018 10:00 AM (Pacific)  
Exported on 04/11/2018

Line Totals (Unit Price \* Quantity)

| Item Num | Section   | Description                         | Reference  | Unit of Measure | Quantity | Mariposa Landscapes, Inc. - |
|----------|---|-------------------------------------|--|-----------------|----------|-----------------------------|
| 31       | Cost for Additional Work Added To Base Work as Needed, Turf | Trees, Shrubs, Ground Cover         | Service Level 1; Once Per Week                                       | Square Foot     | 1        | \$0.0100                    |
| 32       | Cost for Additional Work Added To Base Work as Needed, Turf | Trees, Shrubs, Ground Cover         | Service Level 2; Twice Per Week                                      | Square Foot     | 1        | \$0.0150                    |
| 33       | Zone 02 Alternative Bid Item Number 2                       | Additional Weed Abatement in Paseos | Please Provide Cost For One<br>Additional Weed Abatement Per<br>Year | LS              | 1        | \$20,448.0000               |

Attachment: Agreement for On-Site and/or Professional Services (3332 : APPROVE THE FIRST



## PROPOSED PROJECT WORK SCHEDULES

The following pages include a monthly and an annual schedule sheet for each area identified in this RFP.

Schedule sheets shall be completed by the Proposer for the General Provision services described in Exhibit A.

Prepare the monthly and annual schedule sheets for only the current service levels for each landscape maintenance area, as identified in the Frequency of Services Table, Exhibit E, Schedule II.

Within 30 days of agreement award, the Contractor will provide the City with mapped work schedules for each landscape maintenance area included in this RFP.

### MONTHLY SCHEDULE SHEET

On a separate sheet for each landscape maintenance area included in this RFP, list all tasks specified to be performed on a weekly or monthly basis. Mark the box corresponding to the day of the week/month the work is proposed to be performed.

Be sure to include administrative tasks such as report submittals, meetings, etc.

Fill in the schedule sheet for the entire month. Schedule sheets that are not completed for the entire month will be considered to be non-responsive.

### ANNUAL SCHEDULE SHEET

On a separate sheet for each landscape maintenance area included in this RFP, list all tasks specified to be performed at intervals greater than one (1) month. Mark the box corresponding to the month(s) of the year in which they are either so specified, or if not specified, the month(s) in which the work is proposed to be performed.

Be sure to include any administrative tasks such as report submittals, meetings, etc.

Fill in the schedule sheet for the entire year. Schedule sheets that are not completed for the entire year will be considered to be non-responsive.

### SCHEDULE SHEETS TO FOLLOW

**Monthly Schedule Sheets**  
Proposed Project Work Schedules

**Maintenance of Parkway, Median, and Open Space Landscaping and Irrigation  
Zone 02 Planters – Level 1 Service (4 week)**

| Monday  | Tuesday   | Wednesday     | Thursday      | Friday        |
|---|---|---------------|---------------|---------------|
| <b>Week 1</b>   |   |               |               |               |
| -Debris/litter (partial)<br>-Shrub & GC care (partial)<br>-Weed control (partial)<br>-Irrigation inspect/adjust<br>-Reports | -Debris/litter (partial)<br>-Shrub & GC care (partial)<br>-Weed control (partial)<br>-Irrigation inspect/adjust<br>-Reports | NO WORK       | NO WORK       | NO WORK       |
| <b>Week 2</b>   |   |               |               |               |
| Same as above   | Same as above   | Same as above | Same as above | Same as above |
| <b>Week 3</b>   |   |               |               |               |
| Same as above   | Same as above   | Same as above | Same as above | Same as above |
| <b>Week 4</b>   |   |               |               |               |
| Same as above   | Same as above   | Same as above | Same as above | Same as above |

Attachment: Agreement for On-Site and/or Professional Services (3332 : APPROVE THE FIRST AMENDMENT TO THE ON-SITE AND/OR

**Monthly Schedule Sheets**  
Proposed Project Work Schedules

**Maintenance of Parkway, Median, and Open Space Landscaping and Irrigation  
Zone 02 Open Space (Paseos) – Level 1 Service (4 week)**

| Monday  | Tuesday   | Wednesday     | Thursday      | Friday        |
|---|---|---------------|---------------|---------------|
| Week 1  |   |               |               |               |
| -Debris/litter (partial)<br>-Shrub & GC care (partial)<br>-Weed control (partial)<br>-Irrigation inspect/adjust<br>-Reports | -Debris/litter (partial)<br>-Shrub & GC care (partial)<br>-Weed control (partial)<br>-Irrigation inspect/adjust<br>-Reports | NO WORK       | NO WORK       | NO WORK       |
| Week 2  |   |               |               |               |
| -Irrigation inspect/adjust<br>-Reports  | Same as above   | Same as above | Same as above | Same as above |
| Week 3  |   |               |               |               |
| Same as above   | Same as above   | Same as above | Same as above | Same as above |
| Week 4  |   |               |               |               |
| Same as above   | Same as above   | Same as above | Same as above | Same as above |

Attachment: Agreement for On-Site and/or Professional Services (3332 : APPROVE THE FIRST AMENDMENT TO THE ON-SITE AND/OR

## Annual Schedule Sheets

Proposed Project Work Schedules

### Maintenance of Parkway, Median, and Open Space Landscaping and Irrigation Zone 02 Planters – Level 1 Service (4 week)

| <b>JANUARY</b>   | <b>FEBRUARY</b>  | <b>MARCH</b>   |
|--|--|--|
| Routine Maint.<br>Tree, Shrub & GC Care (as necessary)<br>Weed Control (as necessary)<br>Reports         | Routine Maint.<br>Tree, Shrub & GC Care (as necessary)<br>Weed Control (as necessary)<br>Reports | Routine Maint.<br>Tree, Shrub & GC Care (as necessary)<br>Weed Control (as necessary)<br>Pre-emergent<br>Reports         |
| <b>APRIL</b>   | <b>MAY</b>   | <b>JUNE</b>  |
| Routine Maint.<br>Tree, Shrub & GC Care (as necessary)<br>Fertilize shrubs & GC w/<br>23-5-10<br>Reports | Routine Maint.<br>Tree, Shrub & GC Care (as necessary)<br>Weed Control (as necessary)<br>Reports | Routine Maint.<br>Tree, Shrub & GC Care (as necessary)<br>Weed Control (as necessary)<br>Reports                         |
| <b>JULY</b>  | <b>AUGUST</b>  | <b>SEPTEMBER</b>   |
| Routine Maint.<br>Tree, Shrub & GC Care (as necessary)<br>Weed Control (as necessary)<br>Reports         | Routine Maint.<br>Tree, Shrub & GC Care (as necessary)<br>Weed Control (as necessary)<br>Reports | Routine Maint.<br>Tree, Shrub & GC Care (as necessary)<br>Fertilize shrubs & GC w/<br>23-5-10<br>Pre-emergent<br>Reports |
| <b>OCTOBER</b>   | <b>NOVEMBER</b>  | <b>DECEMBER</b>  |
| Routine Maint.<br>Tree, Shrub & GC Care (as necessary)<br>Weed Control (as necessary)<br>Reports         | Routine Maint.<br>Tree, Shrub & GC Care (as necessary)<br>Weed Control (as necessary)<br>Reports | Routine Maint.<br>Tree, Shrub & GC Care (as necessary)<br>Weed Control (as necessary)<br>Reports                         |

## Annual Schedule Sheet

Proposed Project Work Schedules

### Maintenance of Parkway, Median, and Open Space Landscaping and Irrigation Zone 02 Open Space (Paseos) – Level 1 Service (4 week)

| <b>JANUARY</b>  | <b>FEBRUARY</b>  | <b>MARCH</b>   |
|---|--|--|
| Routine Maint.<br>Tree, Shrub & GC Care (as necessary)<br>Weed Control (as necessary)<br>Reports                          | Routine Maint.<br>Tree, Shrub & GC Care (as necessary)<br>Weed Control (as necessary)<br>Reports | Routine Maint.<br>Tree, Shrub & GC Care (as necessary)<br>Weed Control (as necessary)<br>Reports |
| <b>APRIL</b>  | <b>MAY</b>   | <b>JUNE</b>  |
| Routine Maint.<br>Tree, Shrub & GC Care (as necessary)<br>Weed Control (as necessary)<br>Annual Weed Abatement<br>Reports | Routine Maint.<br>Tree, Shrub & GC Care (as necessary)<br>Weed Control (as necessary)<br>Reports | Routine Maint.<br>Tree, Shrub & GC Care (as necessary)<br>Weed Control (as necessary)<br>Reports |
| <b>JULY</b>   | <b>AUGUST</b>  | <b>SEPTEMBER</b>   |
| Routine Maint.<br>Tree, Shrub & GC Care (as necessary)<br>Weed Control (as necessary)<br>Reports                          | Routine Maint.<br>Tree, Shrub & GC Care (as necessary)<br>Weed Control (as necessary)<br>Reports | Routine Maint.<br>Tree, Shrub & GC Care (as necessary)<br>Weed Control (as necessary)<br>Reports |
| <b>OCTOBER</b>  | <b>NOVEMBER</b>  | <b>DECEMBER</b>  |
| Routine Maint.<br>Tree, Shrub & GC Care (as necessary)<br>Weed Control (as necessary)<br>Reports                          | Routine Maint.<br>Tree, Shrub & GC Care (as necessary)<br>Weed Control (as necessary)<br>Reports | Routine Maint.<br>Tree, Shrub & GC Care (as necessary)<br>Weed Control (as necessary)<br>Reports |

Attachment: Agreement for On-Site and/or Professional Services (3332 : APPROVE THE FIRST AMENDMENT TO THE ON-SITE AND/OR

### PROPOSED ANNUAL MATERIAL SCHEDULE

Use additional sheets as necessary to provide a full and comprehensive response

#### A. Fertilizers

List the fertilizers to be furnished to execute work tasks specified in Exhibit A.

Specify the type (analysis/brand name), estimated amount of each type to be supplied annually, and estimated annual costs for each type (include applicable sales tax, overhead, and mark-up).

| Type    | Estimated Annual Amount | Estimated Annual Cost |
|---------|-------------------------|-----------------------|
| 23-5-10 | 2,000 lbs               | \$1,320.00            |
| misc    | 1 Lump Sum              | \$ 275.00             |

#### B. Pesticides

List pesticides to be furnished to execute work tasks specified in Exhibit A.

Specify the type (i.e., pre-emergent herbicide, rodent/snail bait, insecticide, etc.), the brand name, estimated amount of each type/brand to be supplied annually, and the estimated annual costs for each type/brand (include applicable sales tax, overhead, and mark-up).

| Type                   | Estimated Annual Amount | Estimated Annual Cost |
|------------------------|-------------------------|-----------------------|
| Glyphosate             | 12 Gal.                 | \$320.00              |
| Pre-emergent           | 5 Gal                   | \$325.00              |
| Fumitoxin/ Gopher bait | 1 Lump Sum              | \$463.00              |

Attachment: Agreement for On-Site and/or Professional Services (3332 : APPROVE THE FIRST AMENDMENT TO THE ON-SITE AND/OR

**EXHIBIT E – CONTRACTOR PROPOSAL  
SCHEDULE III – FORMS**

**RFP NO. 2018-014**

**LANDSCAPE MAINTENANCE – ZONE 02  
Maintenance of Parkway, Median, and Open Space  
Landscaping and Irrigation**

**Attachment: Agreement for On-Site and/or Professional Services (3332 : APPROVE THE FIRST AMENDMENT TO THE ON-SITE AND/OR**

**PROPOSAL AFFIRMATION**

With regard to the information provided hereinabove (Exhibit E: Proposal Submittal Documents), I affirm that:

- 1. All information provided is true and correct to the best of my knowledge, and;
- 2. I understand that a materially false statement willfully or fraudulently made in connection with this proposal may result in the termination of any Contract between the City of Moreno Valley, the Moreno Valley Community Services District and Mariposa Landscapes, Inc., and further, the aforesaid company may be barred from participation in future City contracts and be subject to possible criminal prosecution, and;
- 3. I have legal authority to bind Mariposa Landscapes, Inc. to the terms of this affirmation (See "INSTRUCTIONS TO PROPOSER", Section D – Signature of Contract Proposal).

**For the proposal to be valid, this sheet must be returned with the proposal submission and fully completed with a legible signature and date**

SIGNATURE 

PRINTED NAME Terry Noriega

TITLE President

COMPANY NAME Mariposa Landscapes, Inc.

DATE 03/05/2018

Attachment: Agreement for On-Site and/or Professional Services (3332 : APPROVE THE FIRST AMENDMENT TO THE ON-SITE AND/OR



NON-COLLUSION AFFIDAVIT

STATE OF CALIFORNIA )
COUNTY OF ) §

(NAME) Terry Noriega, affiant

being first duly sworn, deposes and says:

That he or she President of
(Sole Owner, Partner or other proper title)

Mariposa Landscapes, Inc.
(Contractor)

the party making the foregoing bid, that the bid is not made in the interest of, or on behalf of, any undisclosed person, partnership, Contractor, association, organization, or corporation; that the bid is genuine and not collusive or sham; that the bidder has not directly or indirectly induced or solicited any other bidder to put in a false or sham bid, and has not directly or indirectly colluded, conspired, connived, or agreed with any bidder or anyone else to put in a sham bid, or that anyone shall refrain from bidding; that the bidder has not in any manner, directly or indirectly, sought by Agreement, communication, or conference with anyone to fix the bid price of the bidder or any other bidder, or to fix any overhead, profit, or cost element of the bid price, or of that of any other bidder, or to secure any advantage against the public body awarding the Agreement of anyone interested in the proposed Agreement; that all statements contained in the bid are true; and, further, that the bidder has not, directly or indirectly, submitted his or her bid price or any breakdown thereof, or the contents thereof, or divulged information or data relative thereto, or paid, and will not pay, any fee to any corporation, partnership, Contractor association, organization, bid depository, or to any member or agent thereof to effectuate a collusive or sham bid (Public Contract Code Section 7106).

Bidder's Name Terry Noriega
Bidder's Address 6232 Santos Diaz St. Irwindale, CA 91702
Telephone Number (626) 960-0196

Signature of Bidder (handwritten signature) President Title

Attachment: Agreement for On-Site and/or Professional Services (3332 : APPROVE THE FIRST AMENDMENT TO THE ON-SITE AND/OR

# CALIFORNIA ALL-PURPOSE CERTIFICATE OF ACKNOWLEDGMENT

State of California

County of Los Angeles

On March 05, 2018 before me, J. Cho, Notary Public,  
(Here insert name and title of the officer)

Personally appeared Terry Noriega, President

who proved to me on the basis of satisfactory evidence to be the person(s) whose name(s) is/~~are~~ subscribed to the within instrument and acknowledgement to me that he/~~she~~/~~they~~ executed the same in his/~~her~~/~~their~~ authorized capacity(ies), and that by his/~~her~~/~~their~~ signature(s) on the instrument the person(s), or the entity upon behalf of which the person(s) acted, executed the instrument.

I certify under PENALTY OF PERJURY under the laws of the State of California that the foregoing paragraph is true and correct.

WITNESS my hand and official seal.

[Signature]  
Signature of Notary Public



### ADDITIONAL OPTIONAL INFORMATION INSTRUCTIONS FOR COMPLETING THIS

#### FORM

DESCRIPTION OF THE ATTACHED DOCUMENT

AGREEMENT SIGNATURE PAGE  
(Title or description of attached document)

\_\_\_\_\_  
(Title or description of attached document continued)

Number of Pages \_\_\_\_\_

Document Date \_\_\_\_\_

\_\_\_\_\_  
Additional Information

CAPACITY CLAIMED BY THE SIGNER

Individual(s)

Corporate Officer

\_\_\_\_\_  
(Title)

Partner (s)

Attorney-in-Fact

Other \_\_\_\_\_

*Any acknowledgment completed in California must contain verbiage exactly as appears above in the notary section or a separate acknowledgment form must be properly completed and attached to that document. The only exception is if a document is recorded outside of California. In such instances, any alternative acknowledgment verbiage as may be printed on such a document so long as the verbiage does not require the notary to do something that is illegal for a notary in California (i.e. certifying the authorized capacity of the signer). Please check the document carefully for proper notarial wording and attach this form if required.*

- State and County information must be the State and County where the document signer(s) personally appeared before the notary public for acknowledgment.
- Date of notarization must be the date that the signer(s) personally appeared which must also be the same date the acknowledgment is completed.
- The notary public must print his or her name as it appears within his or her commission followed by a comma and then your title (notary public).
- Print the name(s) of document signer(s) who personally appear at the time of notarization.
- Indicate the correct singular or plural forms by crossing off incorrect forms (i.e. ~~he~~/~~she~~/~~they~~, is/~~are~~) or circling the correct forms. Failure to correctly indicate this information may lead to rejection of document recording.
- The notary seal impression must be clear and photographically reproducible. Impression must not cover text or lines. If seal impression smudges, re-seal if a sufficient area permits, otherwise complete a different acknowledgment form.
- Signature of the notary public must match the signature on file with the office of the county clerk.
  - ❖ Additional information is not required but could help to ensure this acknowledgment is not misused or attached to a different document.
  - ❖ Indicate title or type of attached document, number of pages and date.
  - ❖ Indicate the capacity claimed by the signer. If the claimed capacity is a corporate officer, indicate the title (i.e. CEO, CFO, Secretary).
- Securely attach this document to the signed document.

Attachment: Agreement for On-Site and/or Professional Services (3332 : APPROVE THE FIRST AMENDMENT TO THE ON-SITE AND/OR

### CERTIFICATION OF NON-DISCRIMINATION

Pursuant to California Labor Code Section 1735, as added by Chapter 643 statutes of 2039, and as amended,

No discrimination shall be made in the employment of persons upon Public Works because of race, religion creed, color, national origin, ancestry, physical handicaps, mental condition, marital status or sex of such persons, except as provided in Section 12940, of the California Labor Code and every Contractor of Public Works violating this section is subject to all penalties imposed for a violation of the Chapter.

I certify that I have read, and understand the foregoing:

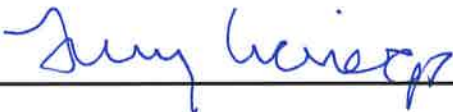
SIGNATURE 

PRINTED NAME Terry Noriega

TITLE President

COMPANY NAME Mariposa Landscapes, Inc.

DATE 03/05/2018

Attachment: Agreement for On-Site and/or Professional Services (3332 : APPROVE THE FIRST AMENDMENT TO THE ON-SITE AND/OR

**Affirmation of Proposal Guarantee**

The undersigned also affirms that:

Accompanying this Proposal is a cashier's check, a certified check, or a Bid Bond for 10% of bid amount, payable to the City of Moreno Valley, which is deemed to constitute liquidated damages, if, in the event this Proposal is accepted, the undersigned shall fail to execute the Agreement and furnish satisfactory bonds under the conditions and within the time specified in this Proposal, otherwise said cash, cashier's check, certified check or Bid Bond is to be returned to the undersigned.

Dated  
Contractor Signature  
By  
Contractor Address  
Contractor Telephone Number  
Names and Addresses of Members of the Contractor:  
(If a Corporation)

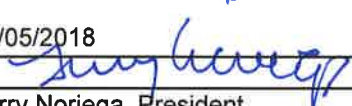
03/05/2018  
  
Terry Noriega, President  
6232 Santos Diaz St. Irwindale, CA 91702  
(626) 960-0196  
Terry Noriega & Antonio Valenzuela  
6232 Santos Diaz St. Irwindale, CA 91702

Signature of Contractor  
By  
Title  
Business Address  
Incorporated Under Laws of the State of  
State License Number and Classification

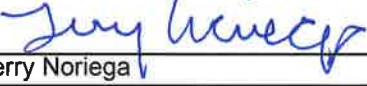
  
Terry Noriega  
President  
6232 Santos Diaz St. Irwindale, CA 91702  
California  
592268. C27.A. C61/D49

President  
Secretary  
Treasurer

  
Antonio Valenzuela

(Corporate Seal)

Attachment: Agreement for On-Site and/or Professional Services (3332 : APPROVE THE FIRST AMENDMENT TO THE ON-SITE AND/OR



## Report to City Council

---

**TO:** Mayor and City Council  
 Mayor and City Council Acting in its Capacity as  
 President and Members of the Board of Directors of the  
 Moreno Valley Community Services District (CSD)

**FROM:** Patti Solano, Parks & Community Services Director

**AGENDA DATE:** January 15, 2019

**TITLE:** NAMING OF PARK LOCATED NEAR RAINBOW RIDGE  
 ELEMENTARY SCHOOL, EAST OF INDIAN AVENUE AND  
 SOUTH OF SANTIAGO AVENUE

---

### **RECOMMENDED ACTION**

#### **Recommendation:**

1. Adopt the name for the new park located within Tract 36760, near Rainbow Ridge Elementary School, east of Indian Street and south of Santiago Avenue, as "Santiago Park."

### **SUMMARY**

This report recommends approval of naming a new park located in Tract 36760, near Rainbow Ridge Elementary School, east of Indian Street and south of Santiago Avenue, as "Santiago Park."

At their regular meeting on November 1, 2018, the Parks, Community Services and Trails Committee, by unanimous vote by the members present, recommended that the City Council name the park, "Santiago Park."

### **DISCUSSION**

Naming of Parks and Community Services facilities should assist in it being easily recognizable and relevant to its location and/or surroundings. Per the Park Naming Policy, past practice has been to name sites after either a dedicated city street, avenue, boulevard, housing tract, school site, or other significant landmark.

The 2.8-acre park site is adjacent to March Middle School and Rainbow Ridge Elementary School and is situated east of Indian Street and south of Santiago Avenue. Based on the location, park names of “Rainbow Ridge Park” and “Santiago Park” were considered by staff.

At their regular meeting on November 1, 2018, the Parks, Community Services and Trails Committee, by unanimous vote by the members present, recommended that the City Council name the facility “Santiago Park.”

The neighborhood park will include amenities such as play structures, picnic shelters, a walking trail, open turf, and restroom facility as indicated on the attached site plan.

### **ALTERNATIVES**

1. Approve naming the park site “Santiago Park.”
2. Select an alternative name for the park.

### **FISCAL IMPACT**

There is no fiscal impact as a result of this action.

### **NOTIFICATION**

Posting of the agenda in accordance with the Brown Act.

### **PREPARATION OF STAFF REPORT**

Prepared By:  
Patti Solano  
Parks & Community Services Director

Department Head Approval:  
Patti Solano  
Parks & Community Services Director

### **CITY COUNCIL GOALS**

**Positive Environment.** Create a positive environment for the development of Moreno Valley's future.

**Community Image, Neighborhood Pride and Cleanliness.** Promote a sense of community pride and foster an excellent image about our City by developing and executing programs which will result in quality development, enhanced neighborhood preservation efforts, including home rehabilitation and neighborhood restoration.

### **CITY COUNCIL STRATEGIC PRIORITIES**

1. Economic Development
2. Public Safety
3. Library

- 4. Infrastructure
- 5. Beautification, Community Engagement, and Quality of Life
- 6. Youth Programs

Objective 5.5: Promote a healthy community and lifestyle.

Objective 6.2: Improve health, wellness and fitness for Moreno Valley youth through recreation and sports programs.

**ATTACHMENTS**

- 1. Park Naming Policy
- 2. Proposed Santiago Park Plan

**APPROVALS**

|                         |                   |                  |
|-------------------------|-------------------|------------------|
| Budget Officer Approval | <u>✓ Approved</u> | 12/11/18 4:25 PM |
| City Attorney Approval  | <u>✓ Approved</u> | 1/03/19 2:11 PM  |
| City Manager Approval   | <u>✓ Approved</u> | 1/08/19 3:39 PM  |

## PARK NAMING POLICY

---

**PURPOSE:** The rapid development of the City of Moreno Valley's park system will afford an exciting opportunity to appropriately name each new park/facility that is constructed within our City. To facilitate this process, the following guidelines have been adopted.

**POLICY:**

**I. Approval of Name:**

- A. Public participation in the name selection process will be encouraged.
- B. Proposed names for parks and recreation facilities will be solicited by staff and submitted to the Parks and Recreation Commission for review and approval.
- C. After approval of the Parks and Recreation Commission, the proposed name(s) will be forwarded to the City Council for final review and approval.

**II. Criteria for Selection of Names:**

- A. The park/facility may be named after a dedicated City street, avenue, or boulevard.
- B. The park/facility may be named after a housing tract that the project is located within.
- C. If the park/facility is located adjacent to a school site, the park may bear the same name as the school.
- D. A park/facility may be named after various significant or historical features that are unique to Moreno Valley, i.e. geographical features, historical events, native birds and/or wildlife, etc.
- E. Although there are many fine individuals both living and deceased who have made significant contributions to the development of the City of Moreno Valley, it shall be the policy of the Parks and Recreation Commission to not consider naming parks in honor of individual persons. Consideration may be given to naming buildings and/or other facilities in honor of individual persons.

---

Approved by: City Council

September 3, 1991

*Revised 6/8/04*



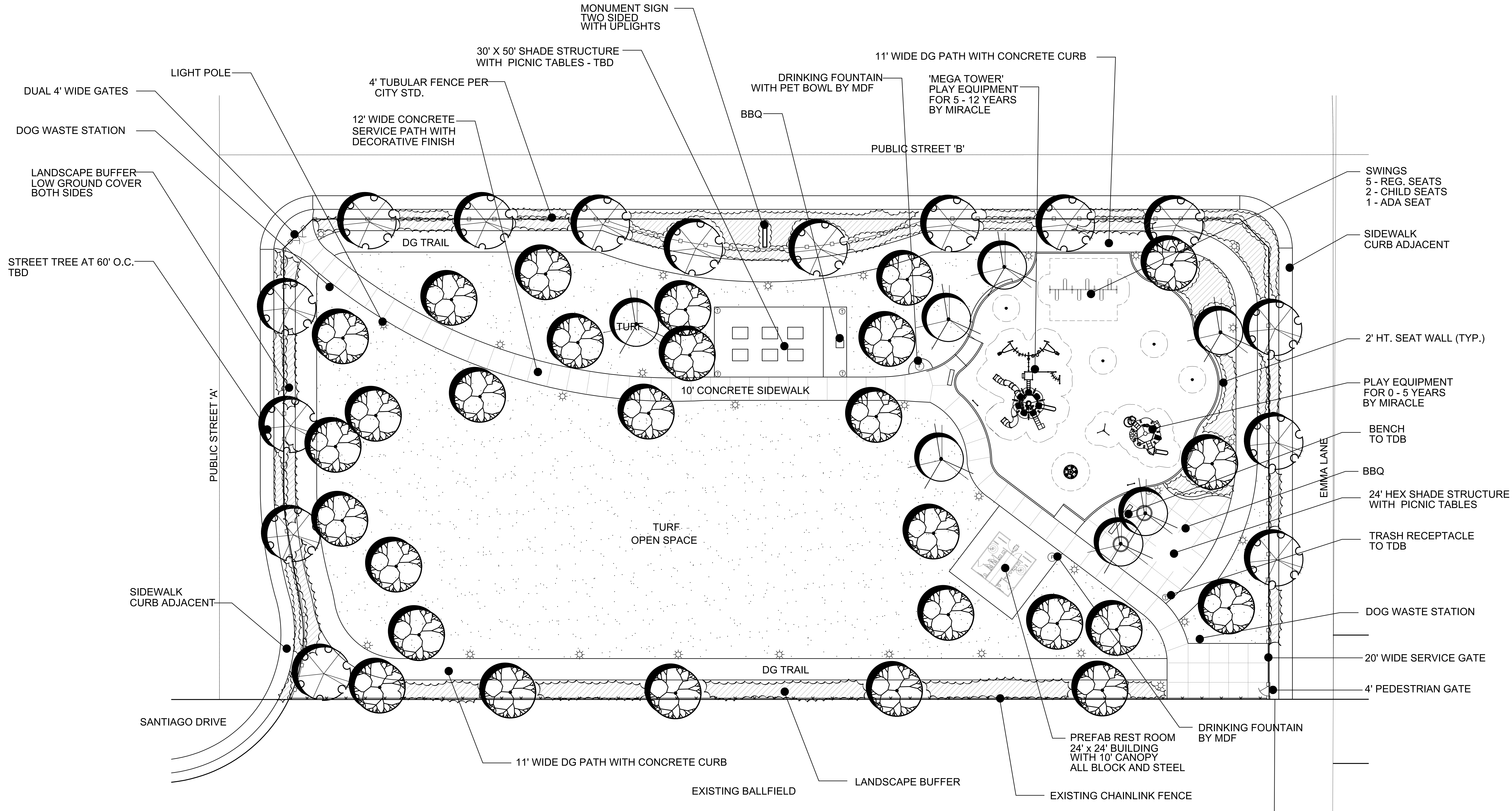

MISSION PACIFIC LAND COMPANY  
4100 NEWPORT PLACE, SUITE 480, NEWPORT BEACH, CA 92660

**LEGACY PARK**  
MORENO VALLEY, California

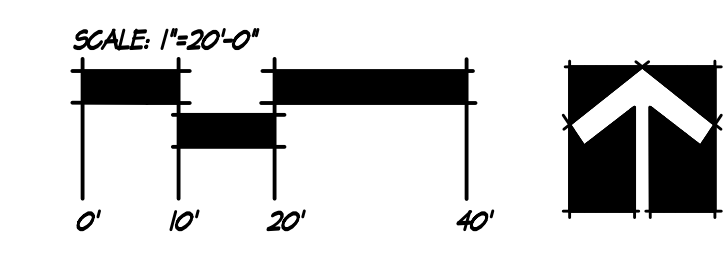

**HJG** HERMANN DESIGN GROUP  
77899 VOKE ROAD  
PALMDALE, CA 92211  
TEL (760) 777-9131 FAX (760) 777-9132

DATE: 4/16/15



## Report to City Council

---

**TO:** Mayor and City Council

**FROM:** Michael L. Wolfe, P.E., Public Works Director/City Engineer

**AGENDA DATE:** January 15, 2019

**TITLE:** PUBLIC HEARING FOR ONE NATIONAL POLLUTANT DISCHARGE ELIMINATION SYSTEM MAIL BALLOT PROCEEDING

---

### **RECOMMENDED ACTION**

#### **Recommend that the City Council:**

1. Conduct the Public Hearing and accept public testimony for the mail ballot proceeding(s) for the National Pollutant Discharge Elimination System (NPDES) Common Interest, Commercial, Industrial, and Quasi-Public Use maximum Regulatory Rate to be applied to three property tax bill(s);
2. Direct the City Clerk to open and count the returned NPDES ballot(s);
3. Verify and accept the results of the mail ballot proceeding(s) as maintained by the City Clerk on the Official Tally Sheet;
4. Receive and file the Official Tally Sheet with the City Clerk's office; and,
5. If approved, set the rate and impose the NPDES Common Interest, Commercial, Industrial, and Quasi-Public Use Regulatory Rate on the Assessor's Parcel Number(s) as mentioned.

### **SUMMARY**

The action before the City Council is to conduct a Public Hearing for one NPDES mail ballot proceeding. The process to accept three parcel(s) into the City's NPDES funding program impacts one property owner, not the general citizens or taxpayers of the City.

The City requires property owners of development projects to mitigate the cost of certain impacts created by the proposed development, such as the cost of complying with state

and federal NPDES requirements. The City offers the NPDES funding program to assist property owners in satisfying the requirement. After a property owner approves the City's NPDES rate through a mail ballot proceeding, the City can levy the rate on the annual property tax bill(s) of the authorized parcel(s).

As a condition of approval for development of their project(s), Duke Realty LTD Partnership (the "Property Owner") is required to provide a funding source for the NPDES program and has requested the City conduct a mail ballot proceeding to satisfy the condition of approval. If the Property Owner approves the mail ballot and the City Council accepts the results, the condition of approval will be satisfied for their project. Tonight's Public Hearing is a required part of the process.

**DISCUSSION**

The Clean Water Act of 1987 established requirements for the discharge of Urban Runoff from Municipal Separate Storm Sewer Systems under the NPDES program. The Santa Ana Regional Water Quality Control Board administers the NPDES program through the issuance of a Permit. The NPDES program requires public agencies to obtain coverage under the Permit to discharge urban stormwater runoff from municipally owned drainage facilities, including streets, highways, storm drains, and flood control channels. The City's current NPDES Permit requires all new development projects to comply with stormwater management requirements.

The City Council adopted the NPDES Residential Regulatory Rate on June 10, 2003, and the NPDES Common Interest, Commercial, Industrial, and Quasi-Public Use Regulatory Rate ("Commercial/Industrial Rate") on January 10, 2006. As a condition of approval from the Planning Commission, development projects are required to provide a funding source, consistent with the rates established by the City Council, to support activities for the NPDES program requirements. Revenue received from the rate supports the increased compliance activities related to the development. It also reduces the financial impact to the General Fund to maintain compliance with the unfunded requirements of the Permit.

The Property Owner is approved to construct a 340,178 square foot industrial warehouse/logistics building on the southwest corner of Perris Blvd. and Nandina Ave. As a condition of approval of their project(s), the Property Owner is required to provide a funding source for the NPDES program to mitigate costs of the program created by the development project. Information for the parcel(s) under development (or the "Subject Property") is shown in the table below:

| Property Owner Project   | Assessor's Parcel Number(s)               | Location  | FY 2018/19 Maximum <sup>1</sup> NPDES Commercial/Industrial Rate(s) per Parcel |
|--|---|---|--|
| Duke Realty LTD Partnership<br>Nandina Facility<br>PEN17-0001/SBP18-0015 | 316-210-036, 316-210-037, and 316-210-038 | Southwest corner of<br>Perris Blvd. and<br>Nandina Ave. | \$245.38   |

<sup>1</sup>The NPDES applied rate levied on the property tax bill will be based on the development status of the property at the time rates are evaluated each year, prior to levying them onto the property tax roll.

A property owner has two options to satisfy the condition of approval:

1. Approve the NPDES rate and authorize the City to collect the rate on the annual Riverside County property tax bill(s) through participation in a successful mail ballot proceeding; or
2. Fund an endowment.

The Property Owner elected to have the NPDES rate applied to the annual property tax bill(s) of the Subject Property. Before the City can levy the NPDES rate on the property tax bill(s) of the Subject Property, a property owner must first approve it and authorize the City to levy it on the annual property tax bill through a mail ballot proceeding. A mail ballot proceeding is a legally required process to approve new charges, or an increase to existing charges, on property tax bills (Proposition 218). The Property Owner was mailed a notice and a ballot to cast their vote (Attachment 1) for their property. Among other things, the notice provides the purpose and amount of the charge and the potential annual inflationary adjustment. The City is required to provide a property owner with 45 days to review the notice and an opportunity to address the City Council (i.e. public comment portion of the Public Hearing). The ballot(s) is due to the City Clerk prior to the close of the Public Hearing. At the close of the Public Hearing, the ballot(s) can be opened and counted, and results announced.

The condition of approval to provide a funding source for the NPDES program will be satisfied with the Property Owner's approval of the NPDES mail ballot (marked yes and signed) and City Council acceptance of the results. In the event a property owner does not return their ballot, does not approve the ballot, or returns an invalid ballot (unmarked or unsigned), this condition of approval will remain unsatisfied and may delay development of their project. In the event more than one mail ballot proceeding is being conducted tonight, each ballot will be counted separately to determine if a property owner approved inclusion of their respective property in the NPDES program.

This action meets the Strategic Plan Priorities to manage and maximize Moreno Valley's public infrastructure to ensure an excellent quality of life, develop and implement innovative, cost effective infrastructure maintenance programs, public facilities management strategies, and capital improvement programming and project delivery.

### **ALTERNATIVES**

1. Conduct the Public Hearing and upon its close, open, count, and verify the returned ballot(s) and accept the results. *Staff recommends this alternative as it will satisfy the project's condition of approval so long as the Property Owner approves their respective ballot.*
2. Open the Public Hearing and continue it to a future regularly scheduled City Council meeting. *Staff does not recommend this alternative as it will*

*delay announcement of the ballot results and may delay project development.*

3. Do not conduct the Public Hearing. *Staff does not recommend this alternative as it will delay the condition of approval from being satisfied and may delay project development. The City will incur additional costs to restart the 45-day noticing period.*
4. Do not conduct the Public Hearing at this time but reschedule it to a date certain during a regularly scheduled City Council meeting. *Staff does not recommend this alternative as it may delay project development and the City will incur additional costs to restart the 45-day noticing period.*

### **FISCAL IMPACT**

Revenue received from the NPDES rate is restricted and can only be used within the stormwater management program. This revenue offsets stormwater management program expenses, which reduces financial impacts to the General Fund and maintains compliance with the unfunded requirements of the Permit. The NPDES rate is only applied to the property tax bills of parcels where approval of the rate has been authorized through a successful mail ballot proceeding.

The fiscal year (FY) 2018/19 maximum NPDES Commercial/Industrial Rate is \$245.38 per parcel, and any division thereof. The maximum NPDES rate for FY 2019/20 and each subsequent FY is subject to an annual inflationary adjustment. The increase to the maximum rate cannot exceed the annual inflationary adjustment without approval of the property owners subject to the charge. The NPDES Commercial/Rate applied to the property tax bill will be based on the development status of the property at the time the rates are calculated for the upcoming FY. The applied rate can be lower than, but cannot exceed the maximum rate. Each year, the City Council must authorize the annual inflationary adjustment to the maximum rate and approve the applied rate prior to its levy on the property tax roll.

### **NOTIFICATION**

The ballot documents were mailed to the Property Owner at least 45 days in advance of the Public Hearing. The documents included a notice, map of the project area, NPDES Commercial/Industrial Rate schedule, NPDES ballot, instructions for marking and returning the ballot, and a postage paid return envelope addressed to the City Clerk.

Newspaper advertising for tonight's Public Hearing was published in The Press-Enterprise on December 27, 2018 and January 3, 2019.

### **PREPARATION OF STAFF REPORT**

Prepared by:  
Isa Rojas  
Management Analyst

Department Head Approval:  
Michael L. Wolfe, P.E.  
Public Works Director/City Engineer

Concurred by:  
Candace E. Cassel  
Special Districts Division Manager

Concurred by:  
Michael Lloyd, P.E.  
Engineering Division Manager/Assistant City Engineer

**CITY COUNCIL GOALS**

**Advocacy.** Develop cooperative intergovernmental relationships and be a forceful advocate of City policies, objectives, and goals to appropriate external governments, agencies and corporations.

**Revenue Diversification and Preservation.** Develop a variety of City revenue sources and policies to create a stable revenue base and fiscal policies to support essential City services, regardless of economic climate.

**CITY COUNCIL STRATEGIC PRIORITIES**

- 1. Economic Development
- 2. Public Safety
- 3. Library
- 4. Infrastructure
- 5. Beautification, Community Engagement, and Quality of Life
- 6. Youth Programs

See the Discussion section above for details of how this action supports the City Council’s Strategic Priorities.

**ATTACHMENTS**

- 1. Duke Realty LTD Partnership Ballot Documents

**APPROVALS**

|                         |                   |                 |
|-------------------------|-------------------|-----------------|
| Budget Officer Approval | <u>✓ Approved</u> | 1/07/19 9:58 AM |
| City Attorney Approval  | <u>✓ Approved</u> | 1/03/19 2:16 PM |
| City Manager Approval   | <u>✓ Approved</u> | 1/08/19 3:30 PM |

Tel: 951.413.3480  
 Fax: 951.413.3170  
 www.moval.org



14177 FREDERICK STREET  
 P.O. BOX 88005  
 MORENO VALLEY, CA 92552-0805

November 29, 2018

Duke Realty LTD Partnership  
 200 Spectrum Center Drive, Suite 1600  
 Irvine, CA 92618

**NOTICE TO PROPERTY OWNER - MAIL BALLOT PROCEEDING FOR THE NATIONAL POLLUTANT DISCHARGE ELIMINATION SYSTEM (NPDES) MAXIMUM COMMERCIAL/INDUSTRIAL REGULATORY RATE FOR APN(s) 316-210-036, 316-210-037 & 316-210-038**

**\*\*\*\*\* OFFICIAL BALLOT ENCLOSED \*\*\*\*\***

### Introduction

In November of 1996, California voters passed Proposition 218 (“The Right to Vote on Taxes Act”). As a result, any new or proposed increase in a property-related charge requires approval by the property owner of record. In compliance with Proposition 218 legislation, the City of Moreno Valley Special Districts Division is conducting a mail ballot proceeding to provide the owner of Assessor’s Parcel Number APN(s) **316-210-036, 316-210-037, and 316-210-038** the opportunity to express support for or opposition to the approval of the NPDES Maximum **Common Interest, Commercial, Industrial, and Quasi-Public Use** Regulatory Rate and services. Approval of the NPDES Maximum **Common Interest, Commercial, Industrial, and Quasi-Public Use** Regulatory Rate through a mail ballot proceeding fulfills the Land Development Division’s Condition of Approval to provide a funding source for the NPDES financial program.

### Background

The Clean Water Act of 1987 established requirements for the discharge of Urban Runoff from Municipal Separate Storm Sewer Systems under the NPDES Program. The NPDES Program is administered by the Santa Ana Regional Water Quality Control Board through the issuance of a Permit. The City’s current NPDES Permit mandates all new development projects comply with storm water management activities. The NPDES Program requires public agencies to obtain coverage under the Permit to discharge urban storm water runoff from municipally owned drainage facilities, including streets, highways, storm drains, and flood control channels.

### Services Provided

In compliance with the Federal Clean Water Act, the City of Moreno Valley shall provide **annual and periodic facility inspections for site design, NPDES permit compliance, and Best Management Practices implementation and maintenance for specified facilities.**

### How is the Amount of the Charge Determined?

Each fiscal year (FY), the City of Moreno Valley determines the type of services necessary to comply with NPDES Permit requirements and levies the rate applicable for that service, not to

Notice of Mail Ballot Proceeding for Duke Realty LTD Partnership  
November 29, 2018

exceed the rate previously approved by the property owner.

### Proposed Charge

For FY 2018/19, the NPDES Maximum **Common Interest, Commercial, Industrial, and Quasi-Public Use** Regulatory Rate is **\$245.38** per parcel. The total amount of the NPDES rates levied for FY 2018/19 was \$515,482.98 for the program as a whole.

### Annual Adjustment

Beginning in FY 2019/20, the NPDES Maximum **Common Interest, Commercial, Industrial, and Quasi-Public Use** Regulatory Rate will be subject to an annual adjustment based on the percentage change calculated for the previous year in the Los Angeles-Long Beach-Anaheim Consumer Price Index for All Urban Consumers, as published by the Department of Labor's Bureau of Labor Statistics.

### Duration of the Charge

Upon approval of the NPDES Maximum Common Interest, Commercial, Industrial, and Quasi-Public Use Regulatory Rate, the annual levy amount will be assessed to APN(s) **316-210-036, 316-210-037, and 316-210-038** (and any division thereof) and shall be placed on the Riverside County property tax bill or included as a monthly charge on a utility bill. The NPDES Maximum **Common Interest, Commercial, Industrial, and Quasi-Public Use** Regulatory Rate will be levied each following year at the proposed rate, which includes an annual inflation adjustment.

### Public Hearing

To provide information concerning this mail ballot proceeding, the City has scheduled a Public Hearing, which will be held at the **Moreno Valley City Hall Council Chamber located at 14177 Frederick Street, Moreno Valley.**

#### Public Hearing

**Tuesday, January 15, 2019**

6:00 p.m.

(Or As Soon Thereafter As The Matter May Be Called)

Tabulation of the returned ballot will commence after the close of the public testimony portion of the Public Hearing. Any ballot received shall be tabulated under the direction of the City Clerk in compliance with the City's Policy for Conducting Mail Ballot Proceedings Policy #1.12.

### Effect if the Charge is Approved

Approval of the NPDES Maximum **Common Interest, Commercial, Industrial, and Quasi-Public Use** Regulatory Rate will be confirmed if the ballot is signed and marked in favor (marked Yes) of the NPDES rate. Approving the NPDES Maximum **Common Interest, Commercial, Industrial, and Quasi-Public Use** Regulatory Rate through a mail ballot proceeding will fulfill the Land Development Division's Condition of Approval to provide an ongoing funding source for the NPDES financial program.



### Effect if the Charge is Not Approved

Not approving the NPDES Maximum **Common Interest, Commercial, Industrial, and Quasi-Public Use** Regulatory Rate to meet state and federally mandated NPDES Permit requirements **will not** satisfy the Land Development Division's Condition of Approval to provide a funding source for the NPDES financial program. If the returned ballot is marked "No", the NPDES rate will not be levied on the property tax bill.

### Effect if the Ballot is Deemed Invalid or Incomplete

Not marking the corresponding box on the ballot in support of or opposition to the proposed program and annual rate and/or not signing the ballot will result in an invalid ballot. In order to satisfy the Land Development Division's Condition of Approval by placement of the NPDES rate on the annual property tax bill, the mail ballot proceeding and 45-day noticing period will need to start over. Reinitiating the process will require payment of the mail ballot proceeding fee.

### For More Information

If you have any questions about the mail ballot proceeding process, please contact Isa Rojas, Management Analyst, with the City's Special Districts Division at 951.413.3480 or via email at [IsaRo@moval.org](mailto:IsaRo@moval.org) or [SpecialDistricts@moval.org](mailto:SpecialDistricts@moval.org) during the City's business hours.

Questions regarding the NPDES financial program, the annual rate, or the Land Development Division's Conditions of Approval should be directed to the Land Development Division at 951.413.3120 or via email at [landdevelopment@moval.org](mailto:landdevelopment@moval.org) during the City's business hours.

The City's business hours are Monday through Thursday from 7:30 a.m. to 5:30 p.m. and Friday from 7:30 a.m. to 4:30 p.m.

### Completing Your Ballot







Please follow the instructions below to complete and return your ballot. Procedures for the completion, return, and tabulation of the ballot are also on file in the City Clerk's office.

1. Mark the enclosed ballot in support of or opposition to the proposed program and annual rate **by placing a mark in the corresponding box**. Ballots received without a designated vote will be considered invalid.
2. Sign your name on the ballot. Ballots received without signature(s) will be considered invalid *and will not be counted*.
3. Mail or personally deliver your completed ballot in a sealed envelope to the City Clerk's office, 14177 Frederick Street, Moreno Valley, California, 92553. For your convenience, a postage-paid envelope has been included for return of the ballot.
4. Ballot(s) must be **received** by the City Clerk prior to the close of the public testimony portion of the Public Hearing scheduled for **January 15, 2019**, at the Moreno Valley City Hall Council Chamber. The Public Hearing will be held at 6:00 p.m. or as soon thereafter as the matter may be called. Ballots received after the close of the Public Hearing cannot be legally counted.

Notice of Mail Ballot Proceeding for Duke Realty LTD Partnership  
November 29, 2018

### Ballot Marks

Appropriate ballot markings include any one of the following for either the YES/Approved or NO/Not Approved blank box:

-  A check mark substantially inside a box;
-  An X mark substantially inside a box;
-  A dot or oval mark substantially inside a box;
-  A completely shaded or filled mark substantially inside a box;
-  A line, single or dashed, or combination of lines, through the box area. Lines may be any one of the following marks: horizontal, vertical, or diagonal. The mark may either run from side to side or corner to corner. All valid lines must be substantially within the box area and not marking any part of another blank box on the ballot;
-  A circle around the box and/or associated clause; or
-  A square or rectangle around the box and/or associated clause.

Balloting marks shall not extend past one box area into any portion of another nor surround the perimeter or any portion of more than one box area. Markings that extend past one box area into any portion of another or surround the perimeter or any portion of more than one box area shall be considered invalid and not counted.

Ballot Mark Revisions (Changes): An error or desire to revise (change) a selection made on the ballot may be completed and returned any time **prior** to the conclusion of public testimony at the Public Hearing. **The revision must be initialed by the record owner(s) of property. Initials must be clearly printed and placed at the right top corner of the revised selection.**

# DUKE REALTY LTD PARTNERSHIP Industrial Facility PEN17-0001

### APN

 316210036

 316210037

 316210038

 Parcels

 City Boundary

 Roads

Map reflects all changes indicated on Riverside County Assessor Maps as of August 17, 2018.

N



G:\Divisions\SpecialDist\2018\MXD\PEN17-0001.mxd

The information shown on this map was compiled from the Riverside County GIS and the City of Moreno Valley GIS. The land base and facility information on this map is for display purposes only and should not be relied upon without independent verification as to its accuracy. Data and information on this map is subject to update and modification. Riverside County and City of Moreno Valley will not be held responsible for any claims, losses or damages resulting from the use of this map. This map is not to be recopied or resold.

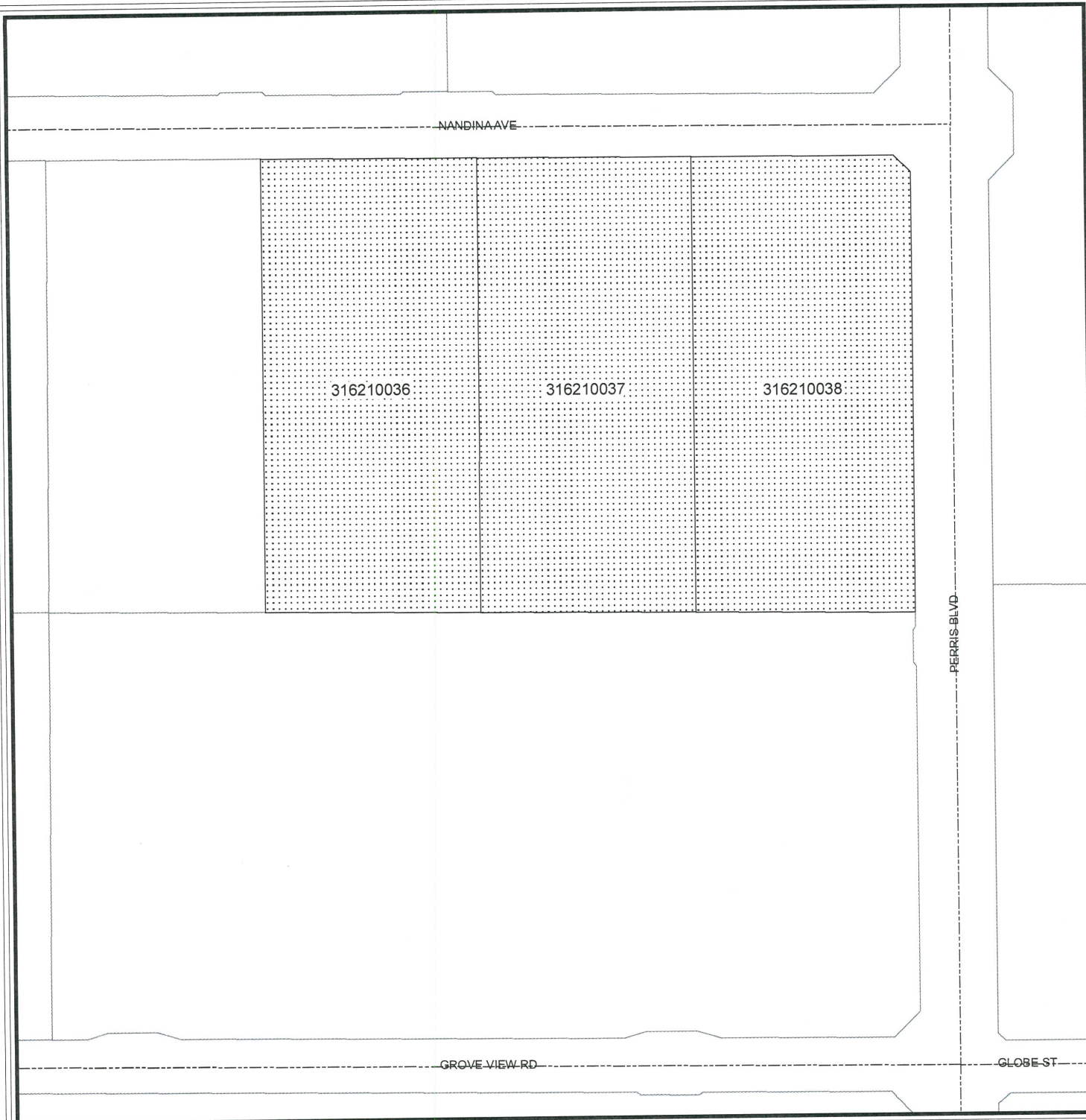

Attachment: Duke Realty LTD Partnership Ballot Documents (3328 : PUBLIC HEARING FOR ONE

**COMMON INTEREST, COMMERCIAL, INDUSTRIAL AND QUASI-PUBLIC USE NPDES RATE SCHEDULE**  
 Adopted by the City Council on January 10, 2006

| LEVEL 1   |                  |                 | LEVEL II  |                  |                 |
|---|------------------|-----------------|---|------------------|-----------------|
| <b>NPDES Administration</b>   |                  |                 | <b>Site Design, Source Control and Treatment Control<br/>BMPs Monitoring and Maintenance</b>  |                  |                 |
| <i>(Not covered by CSA 152)</i>   |                  |                 |   |                  |                 |
| <p>Costs associated with personnel, administration and management of the storm water management program. Administrative tasks include development and filing of various stormwater reports and data collection and management.</p> <p>Level I is levied on all parcels conditioned for the NPDES Rate Schedule.</p> |                  |                 | <p>Costs associated with stormwater and non-stormwater runoff monitoring, inspection of the project's site design, source control and treatment control BMPs; evaluation of site stormwater compliance activities, review of site-specific technical reports and treatment control BMP maintenance records.</p> |                  |                 |
| <p><b>Fiscal Year (FY) 2005/2006 - Base Year Calculation, subject to an annual inflation factor based on the Los Angeles-Riverside-Orange County Regional Consumer Price Index for All Urban Consumers, as published by the Department of Labor's Bureau of Labor Statistics</b></p>                                |                  |                 |   |                  |                 |
| <b>PARCEL RATE</b>  | <b>Per Month</b> | <b>Per Year</b> | <b>PARCEL RATE</b>  | <b>Per Month</b> | <b>Per Year</b> |
|   | \$3.58           | \$42.90         |   | \$16.87          | \$202.48        |

**Inflation Factor Adjustments**

- FY 2006/2007 - 4.5% = (\$33.00 & \$158.00)
- FY 2007/2008 - 3.1% = (\$34.00 & \$163.00)
- FY 2008/2009 - 4.2% = (\$35.00 & \$170.00)
- FY 2009/2010 - no change = (\$35.00 & \$170.00)
- FY 2010/2011 - no change = (\$35.00 & \$170.00)
- FY 2011/2012 - 3.8% = (\$36.00 & \$176.00)
- FY 2012/2013 - 2.7% = (\$37.00 & \$181.00)
- FY 2013/2014 - 2.0% = (\$38.00 & \$185.00) rounded to the nearest dollar
- FY 2014/2015 - 1.14% = (\$39.52 & \$186.49) Pursuant to City Council approval on June 10, 2014.
- FY 2015/2016 - 0.73% = (\$39.81 & \$187.85)
- FY 2016/2017 - 2.03% = (\$40.62 & \$191.66)
- FY 2017/2018 - 1.97% = (\$41.42 & \$195.44)
- FY 2018/2019 - 3.61% = (\$42.90 & \$202.48)

Attachment: Duke Realty LTD Partnership Ballot Documents (3328 : PUBLIC HEARING FOR ONE

**OFFICIAL MAIL BALLOT for Assessor's Parcel Number (APN)  
316-210-036, 316-210-037 & 316-210-038 National Pollutant Discharge  
Elimination System (NPDES)**

**Common Interest, Commercial, Industrial, and Quasi-Public Use Regulatory Rate**

**YES\*** — as property owner of APN(s) 316-210-036, 316-210-037, and 316-210-038, I approve the NPDES Maximum Common Interest, Commercial, Industrial, and Quasi-Public Use Regulatory Rate and services. For fiscal year (FY) 2018/19, the NPDES Maximum Common Interest, Commercial, Industrial, and Quasi-Public Use Regulatory Rate is \$245.38 per parcel. Upon approval of the maximum regulatory rate, the annual levy amount shall be placed on the annual Riverside County property tax bill or included as a monthly charge on a utility bill. Beginning FY 2019/20, the maximum regulatory rate will be subject to an annual adjustment based on the percentage change calculated for the previous year in the Los Angeles-Long Beach-Anaheim Consumer Price Index for All Urban Consumers, as published by the Department of Labor's Bureau of Labor Statistics. The City shall provide annual and periodic facility inspections for site design, NPDES permit compliance, and Best Management Practices implementation and maintenance for specified facilities.

**NO\*\*** — as property owner of APNs 316-210-036, 316-210-037, and 316-210-038, I do not approve the NPDES Maximum Common Interest, Commercial, Industrial, and Quasi-Public Use Regulatory Rate and services. I understand that not approving the NPDES Maximum Common Interest, Commercial, Industrial, and Quasi-Public Use Regulatory Rate to fund state and federally mandated NPDES Permit requirements will not satisfy the project's Conditions of Approval. The NPDES Maximum Common Interest, Commercial, Industrial, and Quasi-Public Use Regulatory Rate will not be levied on the annual Riverside County property tax bill.

| YES*                     | NO**                     | Weighted Ballot Count* | Fiscal Year 2018/19 NPDES Maximum Common Interest, Commercial, Industrial, and Quasi-Public Use Regulatory Rate per Parcel |
|--------------------------|--------------------------|------------------------|--|
| <input type="checkbox"/> | <input type="checkbox"/> | 3                      | \$245.38   |

\*Each Assessor's Parcel Number equals 1 Weighted Ballot.

**This ballot must be received by the City Clerk of the City of Moreno Valley prior to the close of the public testimony portion of the Public Hearing to be held on January 15, 2019, at the Moreno Valley City Hall Council Chamber, 14177 Frederick Street, Moreno Valley, California. The Public Hearing will be held at 6:00 p.m. or as soon thereafter as the matter may be called.**

PROPERTY OWNER SIGNATURE \_\_\_\_\_ DATE \_\_\_\_\_

Please remember to mark the appropriate box, sign and date the ballot, and return to the City Clerk's office in the enclosed envelope prior to the close of the public testimony portion of the January 15, 2019 Public Hearing.

Ballot(s) deemed invalid or incomplete will be discarded and a new process must be initiated in order to place the charge on the annual Riverside County property tax bill, which includes payment of the mail ballot fee.

For administrative convenience all parcels for your project have been combined on one ballot. If you would prefer to have a separate ballot for each APN please call 951.413.3480 to request separate ballots.